



VHV15S12/120
15W SINGLE DC/DC CONVERTER
 60V-140 V_{IN} , 12 V_{OUT} @1.25A

Key Features

- Input-to-output isolation
- Soft start
- Short circuit and thermal protection
- EMI six-sided shielding
- Frequency Jitter Modulation
- Efficiency 84%



Functional Description

The VHV15S12/120 is a 15W single DC/DC converter in a 2×1×0.395-inch package that provides 12 V_{OUT} @1.25A with an operating temperature range from -25°C to +60°C. Switching frequency jitter modulation reduces EMI while its six-sided shielding eliminates RFI. Shielding connection to -Vin to Pin1.

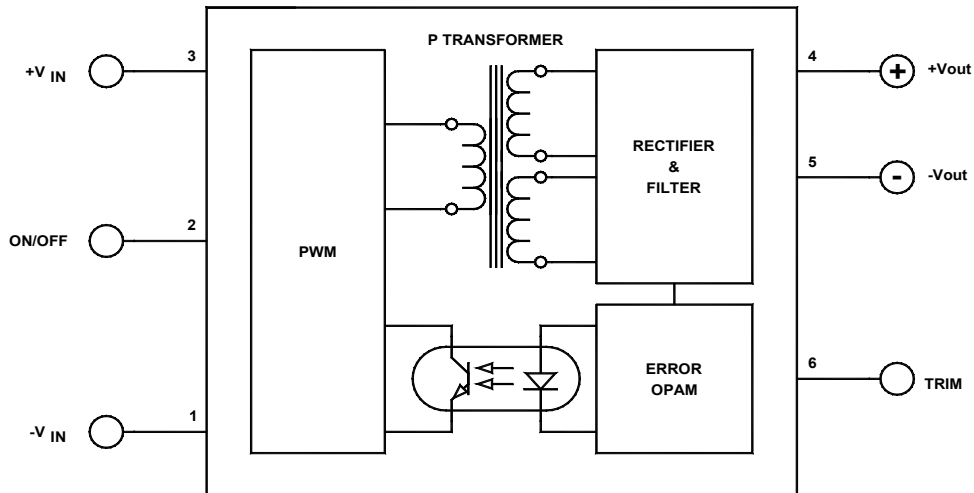

Typical Block Diagram

Electrical Specifications

INPUT SPECIFICATIONS

Unless otherwise specified, all parameters are given under typical +25°C with nominal input voltage and under full output load conditions.

PARAMETER	CONDITION / NOTE	MIN	TYP	MAX	UNIT
Input Voltage Range		60	120	140	Vdc
Input Voltage Slew Rate				10	V/μS
No Load Input Current	@120Vin		5		mA
Full Load Input Current	@120Vin		15		mA
Input Filter	NONE				
Reflected Ripple Current	Measured with 10μF input capacitor		100		mA _{PP}
Reverse Voltage Protection	Parallel Diode		5		A
On/Off	Reference to -V _{IN}				
Converter ON	Open		10		Vdc
Converter OFF	0V, Pin 2 (On/Off) shorted to Pin 1 (-V _{IN})		0	0.8	Vdc
Turn On Delay	Including soft start, See Figure 2		25	35	mS
Startup Input Voltage		150			Vdc

OUTPUT SPECIFICATIONS

PARAMETER	CONDITION / NOTE	MIN	TYP	MAX	UNIT
Output Voltage			12		Vdc
Output Voltage Accuracy			1	2	%
Output Current			1.25		A
Ripple & Noise (20MHz BW)			.5	1	% of V _{OUTPP}
Line Regulation	Outputs fully loaded		1		%
Load Regulation	10% FL to FL		1		%
OVP	5.6V Zener across V		18		Vdc
Temperature Coefficient @ FL			±0.02		%/°C
Short Circuit Protection	Continuous, Current Limit				
Short Circuit Restart	Automatic				
Transient Response (to within 1% of V)	50% FL to 100% FL to 50% FL, See Figure 3		500		μS

GENERAL SPECIFICATIONS

PARAMETER	CONDITION / NOTE	MIN	TYP	MAX	UNIT
Efficiency			75		%
Isol		500	1000		Vdc
Isolation Resistance			10 ⁹		Ω
Isolation Capacitance			300		pF
Switching Frequency		115	130	140	kHz
Frequency Jitter			±4		kHz
Frequency Jitter Modulation			250		Hz

ENVIRONMENTAL SPECIFICATIONS

PARAMETER	CONDITION / NOTE	MIN	TYP	MAX	UNIT
Operating Temperature Range (Ambient)		-25		+60	°C
Storage Temperature Range		-60		+125	°C
Derating	See Figure 4				
Thermal Protection, Turn Off ¹	Junction Temperature		145		°C
Thermal Hysteresis			30		°C
Humidity	Up to 95% non-condensing				
Cooling					
MTBF	per MIL-HNBK217F (Ground benign, +25')				

¹ Input power may have to be recycled after thermal turn off.

PHYSICAL CHARACTERISTICS

PARAMETER	CONDITION / NOTE	MIN	TYP	MAX	UNIT
Dimensions (LxWxH)	2.00x1.00x0.396 in. (50.80x25.40x10.03mm)				
Weight	1.04 oz. (30g)				
Case Material	Coated metal				
Shielding	Six-sided continuous				
Case Connection	-Vin (Pin 1)				

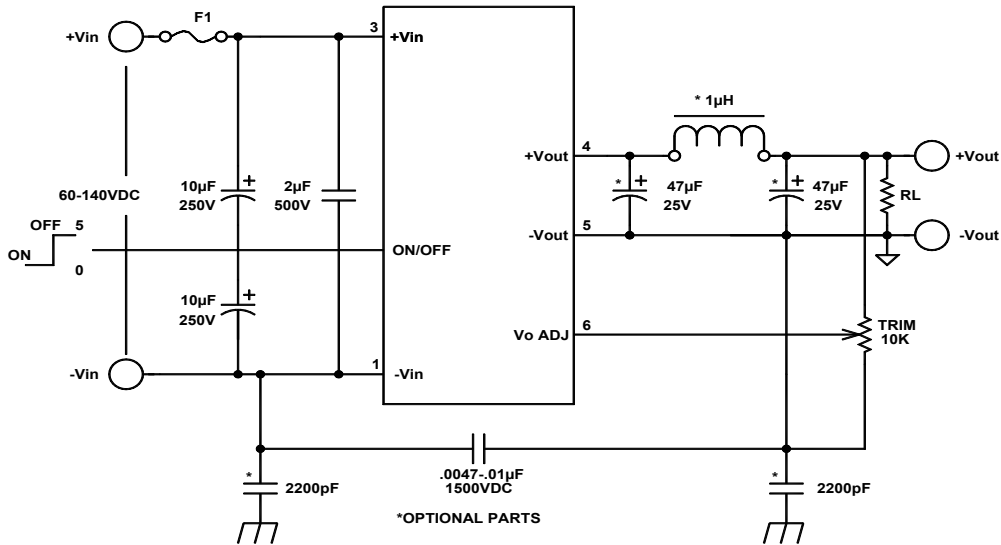
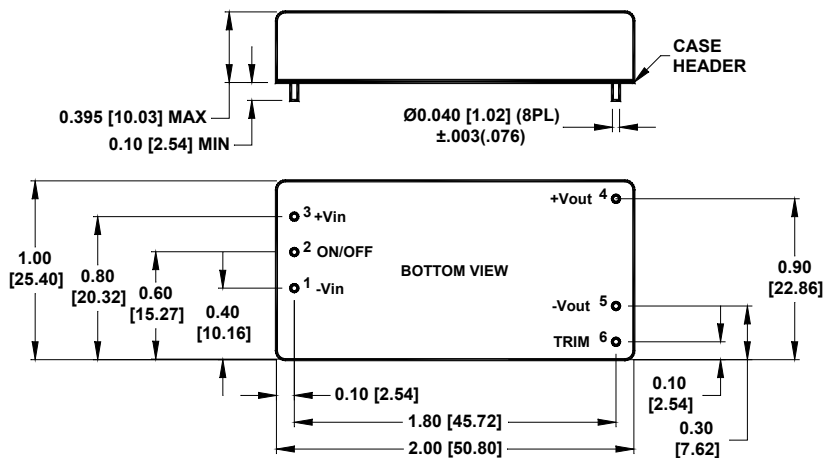

FIGURE 1. Connection diagram

MECHANICAL SPECIFICATIONS

DIMENSIONS ARE IN INCH(mm)
 TOLERANCES: .XX ±.01(.254)
 .XXX ±.005(.127)



Pin	Function
1	-V _{IN}
2	ON/OFF
3	+V _{IN}
4	+V _{OUT}
5	-V _{OUT}
6	TRIM

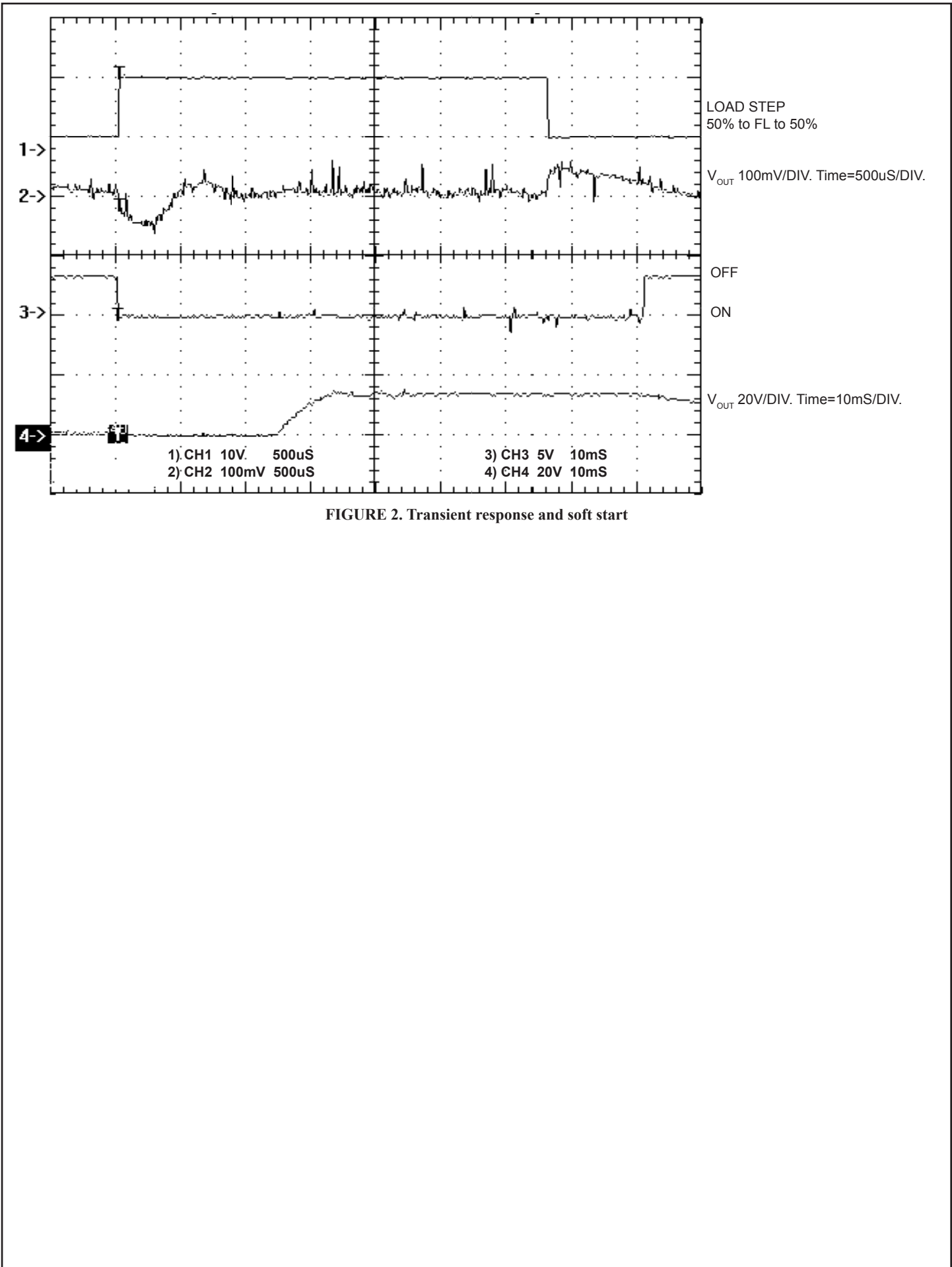

FIGURE 2. Transient response and soft start

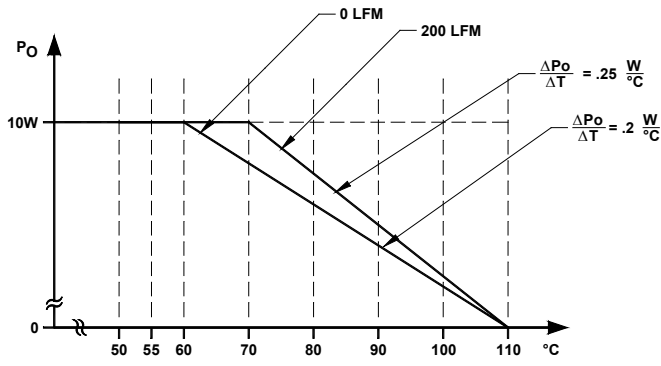

FIGURE 3. Derating of VHV15S12/120

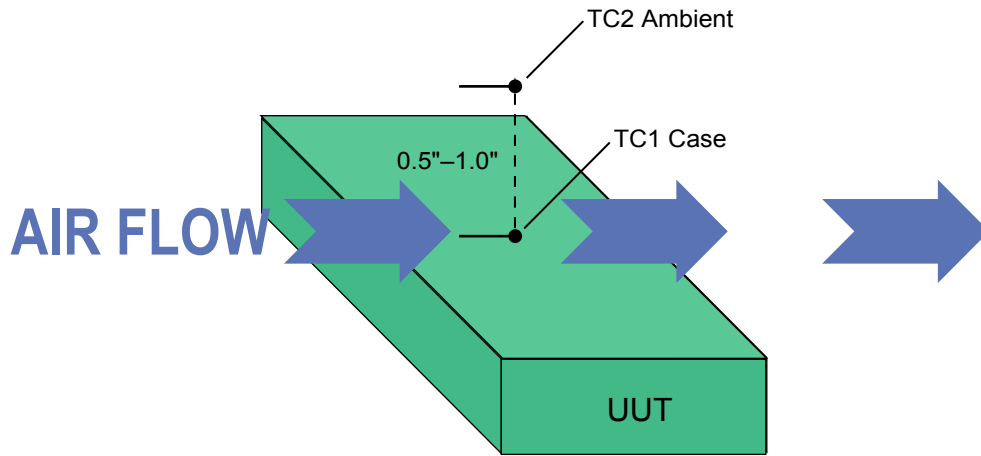

FIGURE 4. Setup for measuring case and ambient temperatures

The ambient temperature is measured with thermo-coupler #2, which is positioned 0.5"-1.0" above the center of the unit. When airflow is used, position the converter such that the 2" length of the converter is perpendicular to the airflow.