



EA60001

60W SINGLE DC/DC CONVERTER
US Patents 6,262,901 B1 & 6,473,317 B1

Key Features

- 89% efficiency
- Output overvoltage protection (OVP)
- Wide input voltage range (2:1)
- Six-sided shielding
- Soft start
- 1500Vdc input-to-output isolation
- Short circuit and thermal protection
- Adjustable output
- 400µA off state current
- Output synchronous rectification
- Input undervoltage protection



Functional Description

The EA60001 is an isolated 60W single output DC/DC converter that accepts $18V_{IN}$ to $36V_{IN}$ and provides $5V_{OUT}@12A$. Push-pull topology and output synchronous rectification allow for continuous operation even at low input voltages with maximum efficiency. Six-sided shielding with external synchronization minimizes EMI and RFI. Protection features allow the converters to operate in harsh environments.

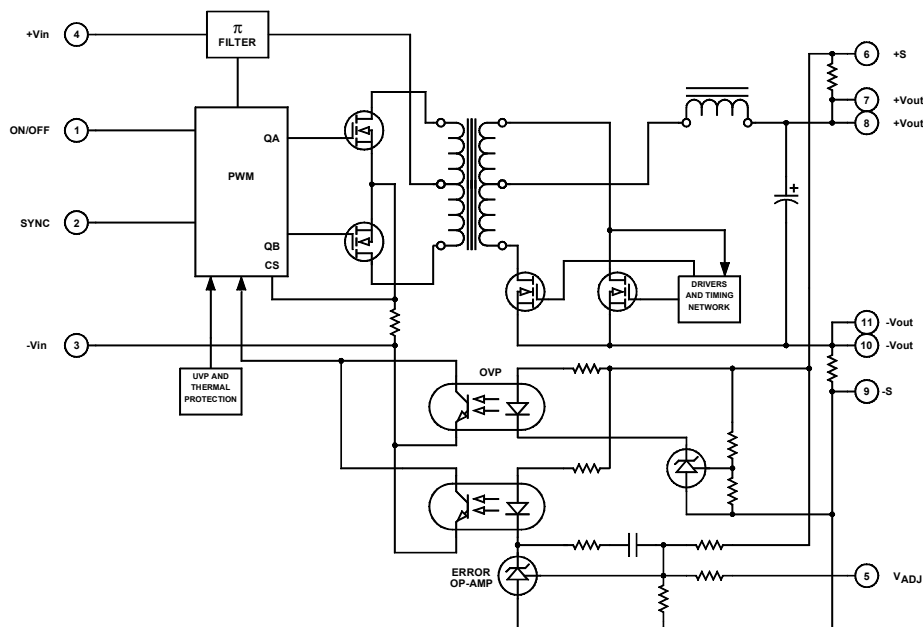

Typical Block Diagram

Electrical Specifications

INPUT SPECIFICATIONS

Unless otherwise specified, all parameters are given under typical +25°C with nominal input voltage and under full output load conditions.

PARAMETER	CONDITION / NOTE	MIN	TYP	MAX	UNIT
Input Voltage Range		18	24	36	Vdc
Input Filter	π				
Reverse Polarity Input Current	External series-blocking diode			12	A
Input Surge Current (20 μ S Spike)				10	A
No Load Input Current			70		mA
Full Load Input Current			2809		mA
Short Circuit Current Limit			150		% I _{IN}
Undervoltage Shutdown		7			Vdc
Off State Current			400		μ A
Remote ON/OFF Control					
Converter ON	Open (Open circuit voltage at Pin 1: 10V Max.)				
Converter OFF		-0.6	0	0.2	Vdc
Logic Input Reference	-Input				
Logic Compatibility	TTL Open Collector or CMOS Open Drain				
Sync Input	TTL	2.5		5	Vdc
Sync Input Frequency Range		310	320	360	kHz
Sync Input Minimum Pulse Width	See Figure 4	200			nS

OUTPUT SPECIFICATIONS

PARAMETER	CONDITION / NOTE	MIN	TYP	MAX	UNIT
Output Voltage			5		Vdc
Output Current			12		A
Output Voltage Accuracy			± 1	± 1.5	%
Output Voltage Adjustment			3	± 5	%
Minimum Load		10			% of FL
Ripple & Noise			1	2	% _{PP}
Line Regulation	Minimum V _{IN} to maximum V _{IN}		± 1	± 2	%
Load Regulation	NL to FL		± 1	± 2	%
Temperature Coefficient @ FL			0.02		%/°C
Transient Response Time (to within 1% of V _{OUT})	50% FL to FL to 50% FL, See Figure 3		50		μ S
Short Circuit Protection	By input current limiting				
Output Short Circuit Duration	Continuous				

GENERAL SPECIFICATIONS

PARAMETER	CONDITION / NOTE	MIN	TYP	MAX	UNIT
Efficiency			89		%
Isolation Voltage (1 min.)			1500		Vdc
Isolation Resistance			10 ⁹		Ω
Isolation Capacitance			80		pF
Switching Frequency			150		kHz

ENVIRONMENTAL SPECIFICATIONS

PARAMETER	CONDITION / NOTE	MIN	TYP	MAX	UNIT
Operating Temperature, Industrial (Ambient)	See Figure 2	-40		+75	°C
Storage Temperature Range		-55		+125	°C
Thermal Resistance			2.25	2.50	°C/W _{DISS}
Maximum Operating Case Temperature				105	°C
Thermal Turn Off, Case Temperature		90	100	105	°C
Thermal Hysteresis			10		°C
Derating	See Figure 2				
Humidity	Up to 95% non-condensing				
Cooling	Free-air convection				
EM/RFI	Six-sided continuous shielded metal case				
MTBF	per MIL-HNBK-217F (Ground benign, +25°C)		625,000		hours

PHYSICAL CHARACTERISTICS

PARAMETER	CONDITION / NOTE	MIN	TYP	MAX	UNIT
Dimensions (L×W×H)	2.00×2.00×0.50 in. (50.80×50.80×12.70mm)				
Weight	2.78 oz. (79g)				
Case Material	Coated metal				
Shielding Connection	-Input (Pin 3)				

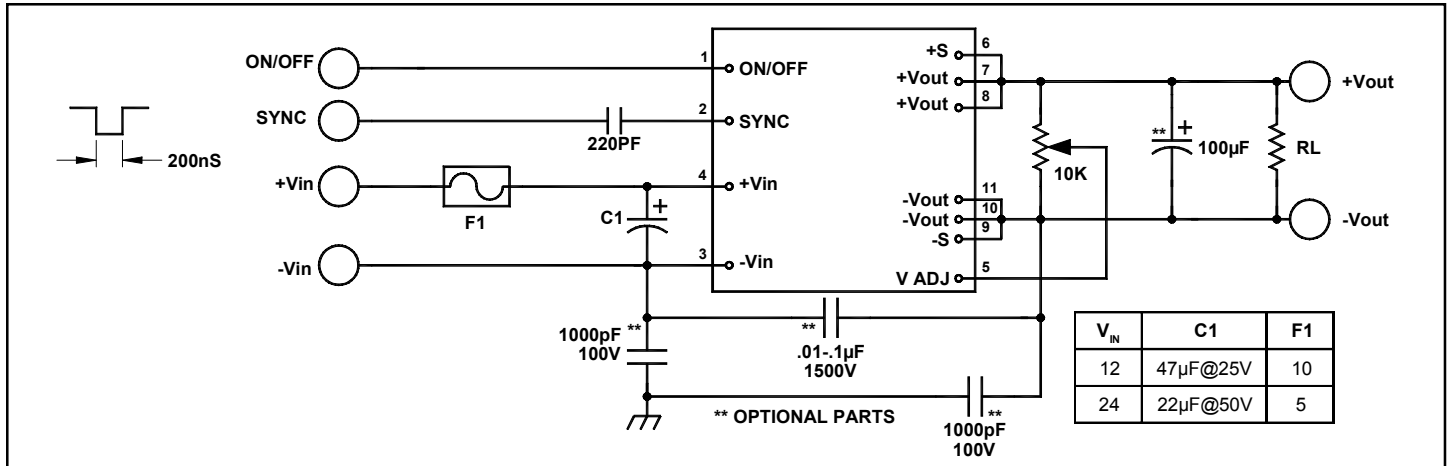

FIGURE 1. Typical connection diagram

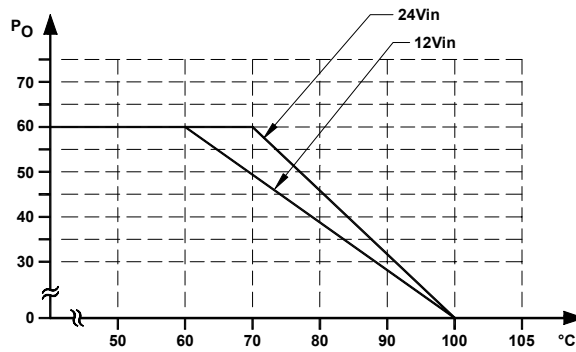
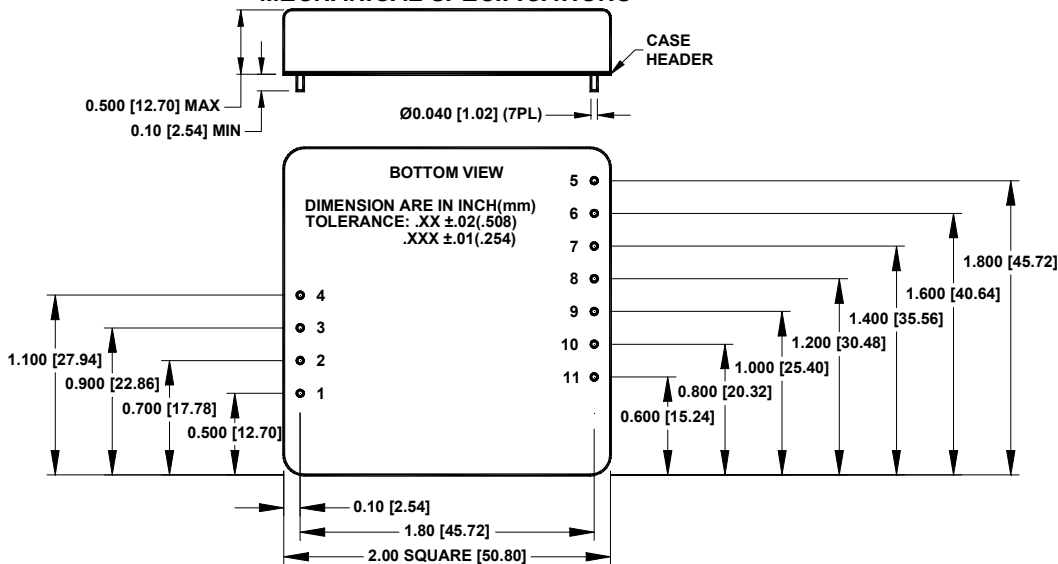

FIGURE 2. Typical derating curve

MECHANICAL SPECIFICATIONS



Pin	Function
	SINGLE
1	ON/OFF
2	SYNC
3	-V _{IN}
4	+V _{IN}
5	V _{OUT} ADJ
6	+SENSE
7	+V _{OUT}
8	+V _{OUT}
9	-SENSE
10	-V _{OUT}
11	-V _{OUT}

EXTERNAL SYNCHRONIZATION

The converter can be synchronized to an external clock by driving the SYNC pin (pin 2) directly. The driving signal frequency must be 330kHz \pm 5% (200nS to 300nS negative going pulse (See Figure 4, Waveform 1)). When the external clock is AC-coupled to the SYNC pin of the converter through a ceramic capacitor, connect a signal

Schotky diode with the cathode connected to the SYNC pin and the anode to $-V_{IN}$ (See Figure 4). AC coupling reduces the power required for driving multiple converters and allows for continuous operation of the other synchronized converters in case the driving signal is missing or a short circuit develops at one of the sync inputs.

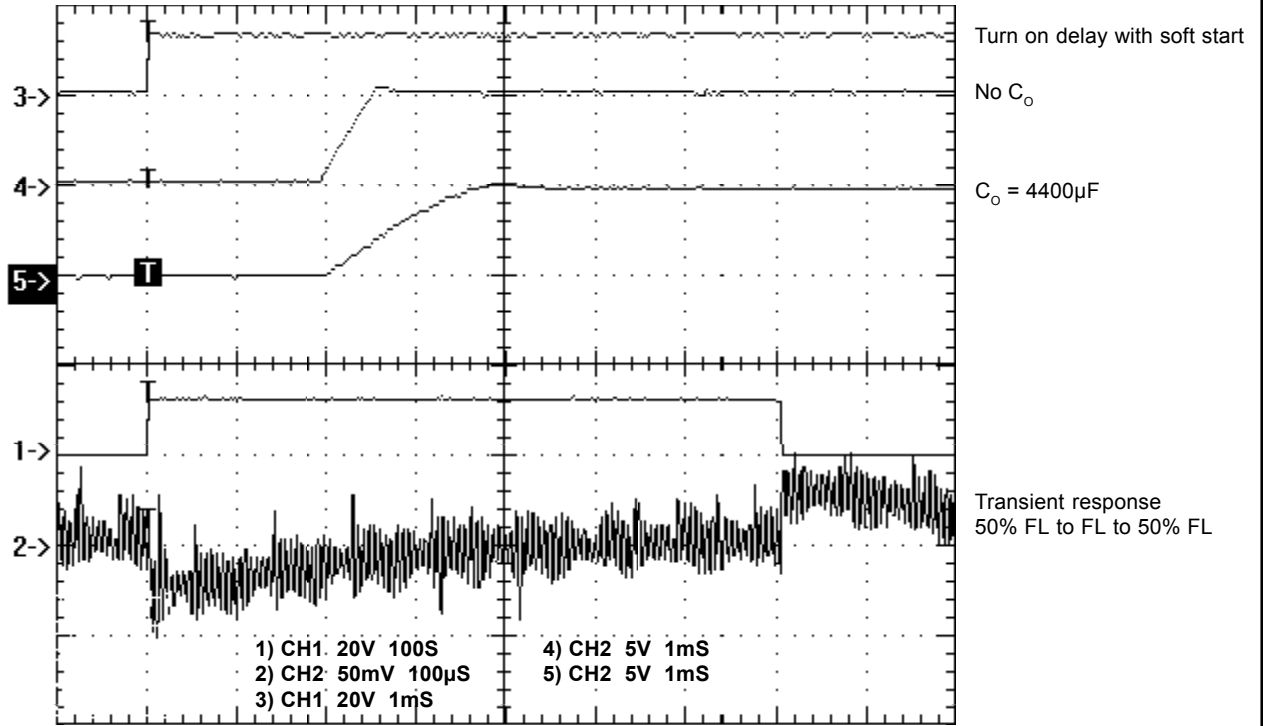

FIGURE 3. Turn on delay with soft start and transient response

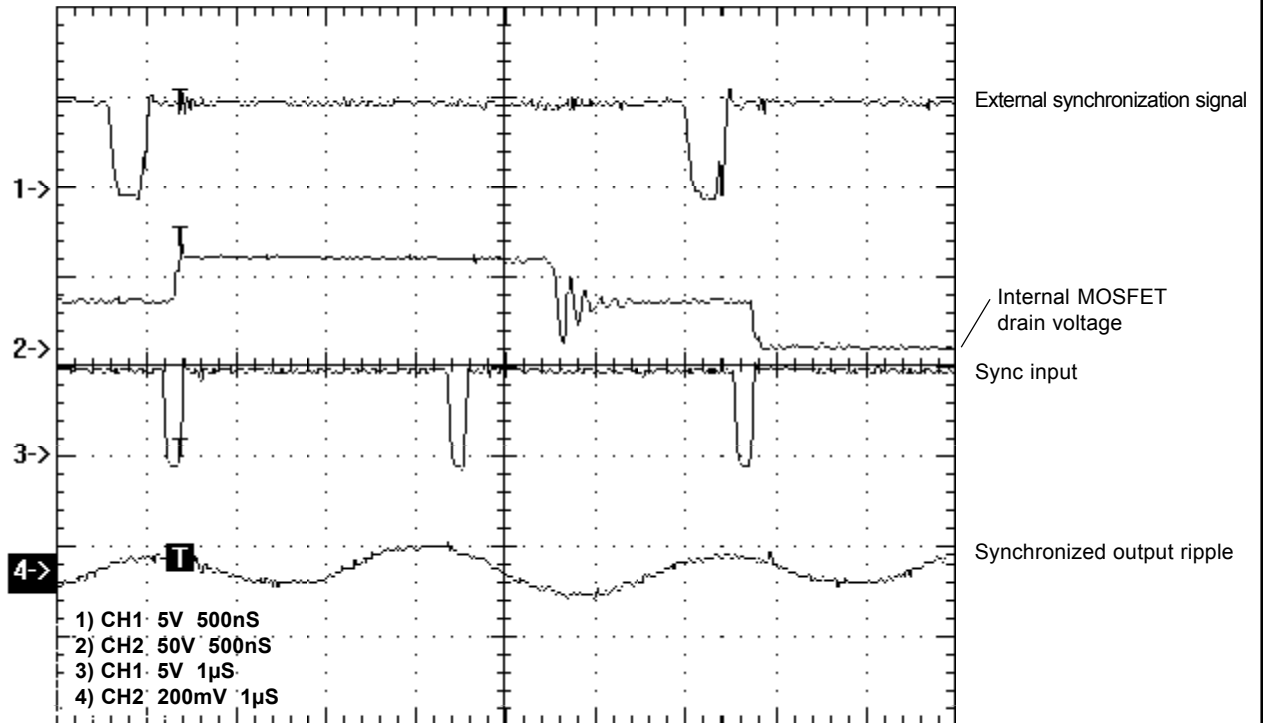

FIGURE 4. Synchronization waveforms