



BD25002

25W TRIPLE DC/DC CONVERTER

$33-75V_{IN}$ $3.3V_{OUT}$

Key Features

- 25 μ S transient response
- 81% efficiency
- Six-sided shielding
- Soft start
- Short circuit protection
- Adjustable output
- 75 μ A off-state current
- Wide input voltage range
- Synchronization
- Industry pinout

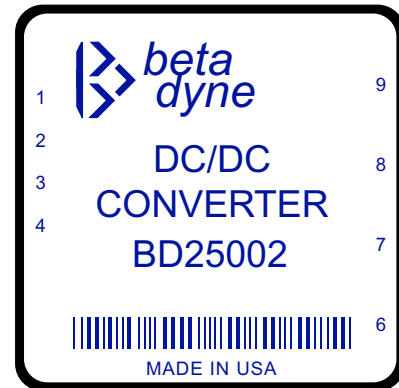

Functional Description

The BD25002 is a triple output converter with an input voltage range of $33V_{IN}$ to $72V_{IN}$ and a main output of $3.3V_{OUT}$ and auxiliary output of $\pm 5V_{OUT}$.

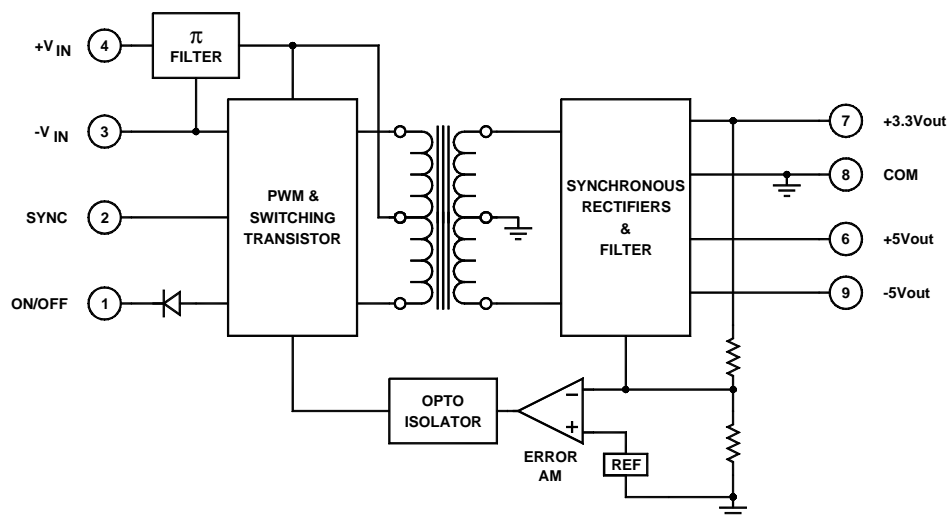

Typical Block Diagram

Electrical Specifications

Unless otherwise specified, all parameters are given under typical +25°C with nominal input voltage and under full output load conditions.

INPUT SPECIFICATIONS

PARAMETER	CONDITION / NOTE	MIN	TYP	MAX	UNIT
Input Voltage Range		33		72	Vdc
Input Filter	LC				
Reverse Polarity Input Current				12	A
Input Surge Current (20µS Spike)				10	A
Short Circuit Current Limit			150		% I _{IN}
Undervoltage Shutdown			8		Vdc
Off State Current			75		µA
Remote ON/OFF Control					
Supply ON	Open (Open circuit voltage: 12V Max.)				
Supply OFF		0		0.8	Vdc
Logic Input Reference	-Input				
Logic Compatibility	TTL Open Collector or CMOS Open Drain				
Converter Standby Current			32		mA

OUTPUT SPECIFICATIONS

PARAMETER	CONDITION / NOTE	MIN	TYP	MAX	UNIT
Voltage Ratings			3.3±5		Vdc
Current Ratings			4/±1.2		A
Output Voltage Accuracy, Triple (Main)			±1		%
Output Voltage Accuracy, Triple (Auxiliary)	Fully loaded		3	±5	%
Voltage Balance, Triple (Auxiliary)	Balanced loads for auxiliary		±1	±2	%
Minimum Load		10			% of FL
Ripple & Noise (Main)	(See App. Note DC-003)		1	2	%V _{PP} of V _{OUT}
Ripple & Noise (Auxiliary)	(See App. Note DC-003)		2		%V _{PP} of V _{OUT}
Line Regulation, Triple (Main)	Minimum V _{IN} to maximum V _{IN}		±1	2	%
Line Regulation, Triple (Auxiliary)	Minimum V _{IN} to maximum V _{IN}		±5	6	%
Load Regulation					
Load Regulation, Triple (Main)	Main fully loaded		±1		%
Load Regulation, Triple (Auxiliary)			5	6	%
Temperature Coefficient @ FL			0.02		%/°C
Transient Response Time	50% FL to FL to 50% FL		25		µS
Short Circuit Protection	All outputs, by input current limiting				
Output Short Circuit Duration	Continuous				

GENERAL SPECIFICATIONS

PARAMETER	CONDITION / NOTE	MIN	TYP	MAX	UNIT
Efficiency			81		%
Isolation Voltage (1 min.)			1500		Vdc
Isolation Resistance			10 ⁹		Ω
Isolation Capacitance			80		pF
Switching Frequency			160		kHz

ENVIRONMENTAL SPECIFICATIONS

PARAMETER	CONDITION / NOTE	MIN	TYP	MAX	UNIT
Operating Temperature, Industrial (Ambient) ¹	See Figure 2	-40		+71	°C
Operating Temperature, Extended	(Please contact factory)				
Storage Temperature Range		-55		+125	°C
Thermal Resistance					°C/W _{DISS}
Maximum Operating Case Temperature				105	°C
Thermal Turn Off, Case Temperature		95	100	115	°C
Thermal Hysteresis		5	10		°C
Derating	See Figure 2				
Humidity	Up to 95% non-condensing				
Cooling	Free-air convection				
EM/RFI	Six-sided continuous shielded metal case				
MTBF	per MIL-HNBK-217F (Ground benign, +25°C)		718,000		hours

* See footnotes 1, 2, 3 and 4

PHYSICAL CHARACTERISTICS

PARAMETER	CONDITION / NOTE	MIN	TYP	MAX	UNIT
Dimensions (LxWxH)	2.00x2.00x0.395 in. (50.80x50.80x10.03mm)				
Weight	2 oz. (58g)				
Case Material	Coated metal				
Shielding Connection, 12V _{IN} , 24V _N	-Input (Pin 3)				
Shielding Connection, 48V _{IN}	+Input (Pin 4)				

¹ Contact factory for -55° to +85°C operating temperature range.

² The maximum input current at any given input range measured at minimum input voltage is given as $1.6 \cdot I_{NOMINAL}$. Nominal input current is the typical value measured at the input of the converter under full-load room temperature and nominal input voltage (12, 24 and 48Vin).

³ Adequate insulation is to be provided to the converters at the end usage as per applicable requirements.

⁴ Temperature rise on the case of the converters is to be considered during the end usage as per applicable requirements.

EXTERNAL SYNCHRONIZATION

All models in the 25W series can be synchronized to an external clock by driving the SYNC pin (pin 2) directly or with an open collector-open drain (1 TTL load). The driving signal frequency must be 380kHz \pm 5% (20% low, 80% high duty cycle). The PWM used in

the 25W series offers bidirectional SYNC ports, which allow multiple unit synchronization by connecting all SYNC pins together. In the absence of an external clock, the faster unit takes control of the SYNC bus and the rest of the units follow.

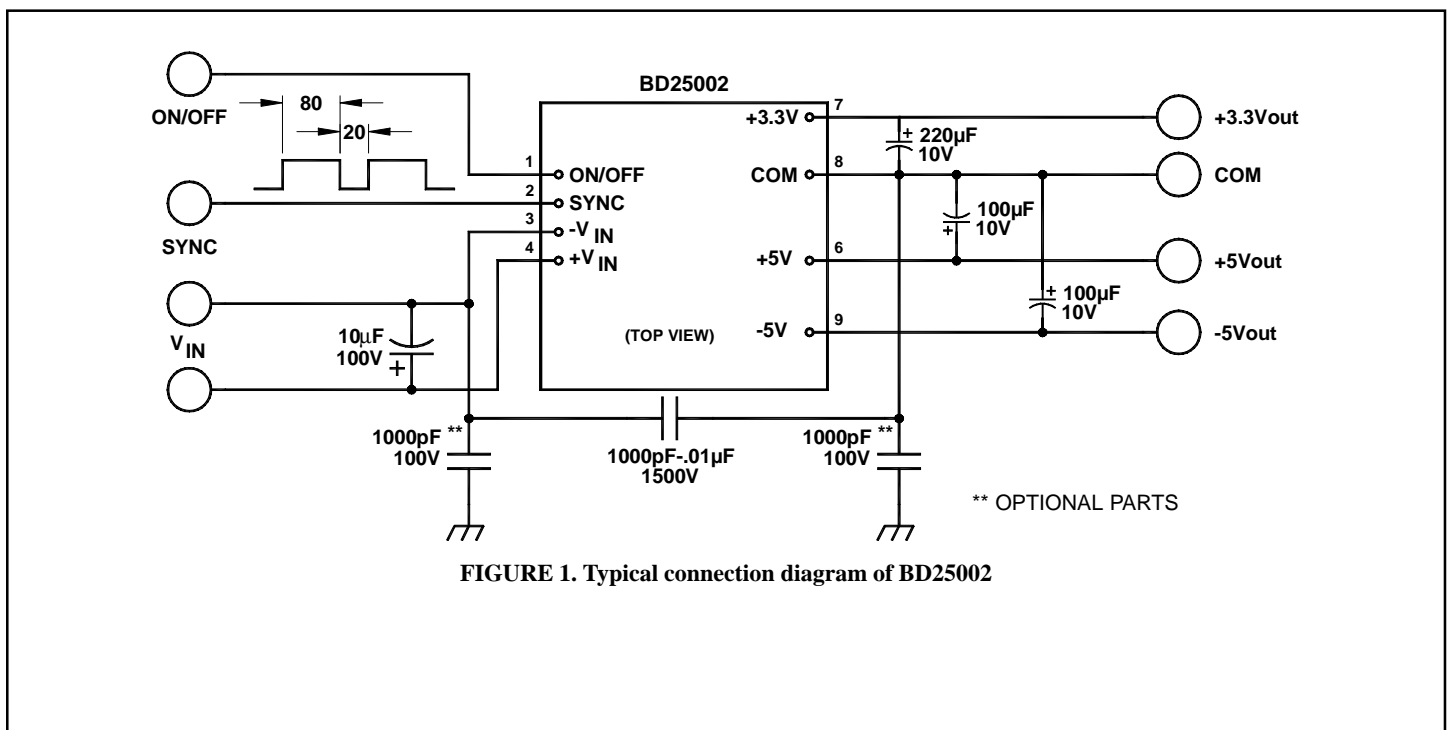

FIGURE 1. Typical connection diagram of BD25002

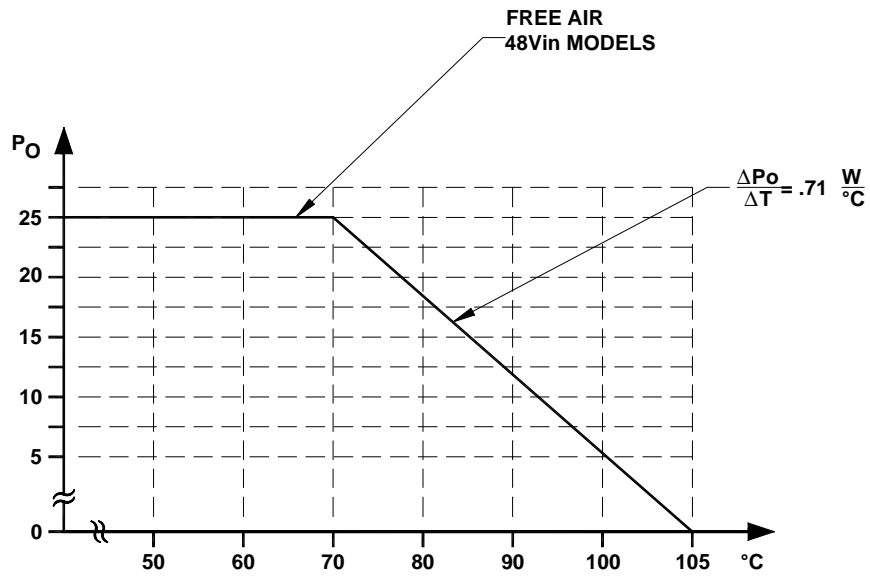
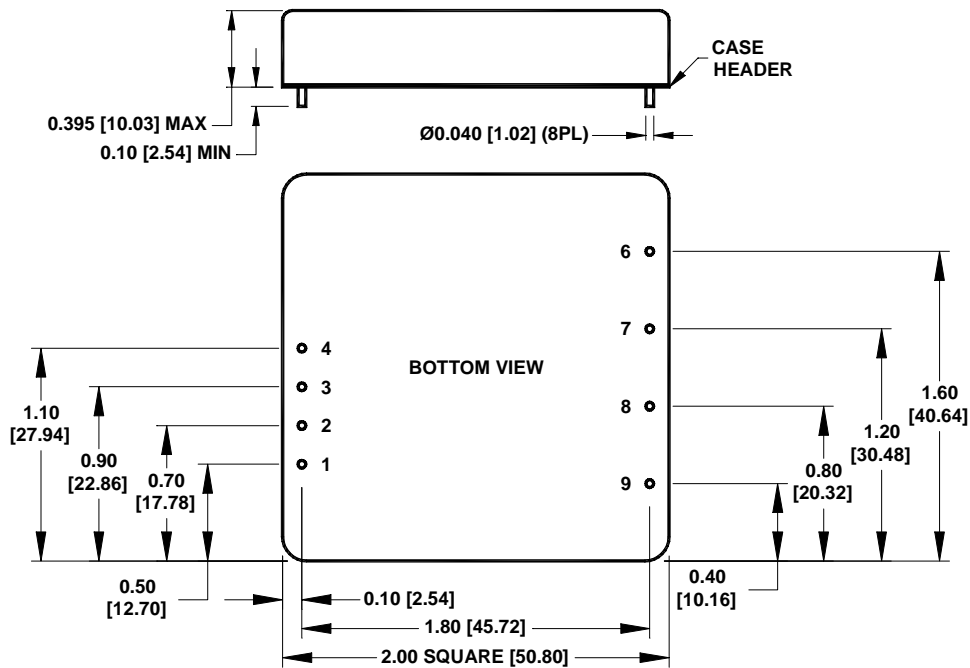

FIGURE 2. Typical derating curve of BD25002

MECHANICAL SPECIFICATIONS

in inches [mm]



Pin	Function
	TRIPLE
1	ON/OFF
2	SYNC
3	-V _{IN}
4	+V _{IN}
5	No Pin
6	+V _{AUX}
7	+V _{OUT}
8	GND
9	-V _{AUX}