



# BD15005

## 10W DUAL DC/DC CONVERTER

$9-36V_{IN}$ ,  $\pm 12V_{OUT}$  @420mA

### Key Features

- 4:1 input voltage range
- 76% efficiency
- Input-to-output isolation
- Soft start
- Short circuit protection
- 150 $\mu$ A off state current
- Multiple converter synchronization
- Output overvoltage protection (OVP)



### Functional Description

The BD15005 is a 10W dual DC/DC converter designed to operate from  $9-36V_{IN}$  and provide a dual regulated  $\pm 12V_{OUT}$  @420mA minimum. Six-sided shielding, SMD and improved thermal techniques guarantee reliability.

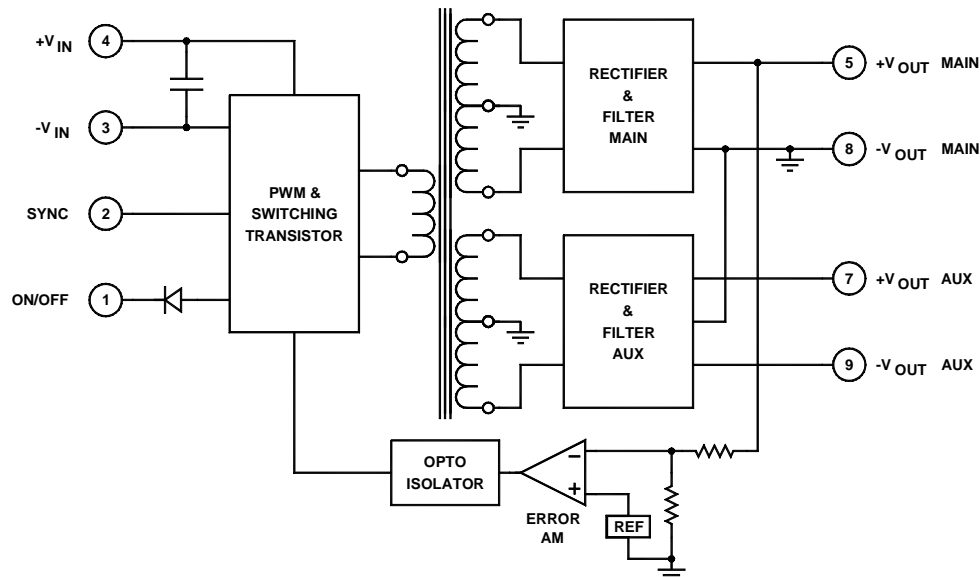

Typical Block Diagram

## Electrical Specifications

Unless otherwise specified, all parameters are given under typical +25°C with nominal input voltage and under full output load conditions.

### INPUT SPECIFICATIONS

PARAMETER	CONDITION / NOTE	MIN	TYP	MAX	UNIT
Input Voltage Range		9	24	36	Vdc
Input Startup Voltage, $24V_{IN}$		7			Vdc
Undervoltage Shutdown	$24V_{IN} = 6V_{dc}$ , $48V_{IN} = 11V_{dc}$		8		Vdc
Input Filter	LC				
Reverse Polarity	External series-blocking diode				
No Load Input Current			20		mA
Full Load Input Current			540		mA
Input Reflected Ripple <sup>1</sup>			120		mA <sub>PP</sub>
Input Surge Current (20 $\mu$ S Spike)				10	A
Short Circuit Current Limit			150		% $I_{IN}$
Off State Current			150		$\mu$ A
Remote ON/OFF Control					
Supply ON	Pin 1 Open (Open circuit voltage: 12V Max.)				
Supply OFF		0		0.8	Vdc
Logic Input Reference	-Input for ON/OFF and SYNC				
Logic Compatibility	TTL Open Collector or CMOS Open Drain				

### OUTPUT SPECIFICATIONS

PARAMETER	CONDITION / NOTE	MIN	TYP	MAX	UNIT
Output Voltage			$\pm 12$		Vdc
Output Voltage Accuracy			$\pm 1$		%
Output Current			$\pm 420$		mA
Output Voltage Adjustment			5		%
Voltage Balance, Dual	Balanced loads			$\pm 2$	%
Minimum Load			10		% of FL
Ripple & Noise	(See App. Note DC-003)		1	2	%V <sub>PP</sub> of V <sub>OUT</sub>
Line Regulation, Dual	Minimum $V_{IN}$ to maximum $V_{IN}$		$\pm 1$	2	%
Load Regulation, Dual <sup>2</sup>	See Figure 5 for isolated output		$\pm 1$		%
Temperature Coefficient @ FL			0.02		%/°C
Transient Response Time	50% FL to FL to 50% FL		100	150	$\mu$ S
Short Circuit Protection	All outputs, by input current limiting				
Turn On Delay with Soft Start			2		mS
Output Overvoltage Protection			130	150	% of V <sub>OUT</sub>

### GENERAL SPECIFICATIONS

PARAMETER	CONDITION / NOTE	MIN	TYP	MAX	UNIT
Efficiency (at full power)			76		%
Isolation Voltage (1 min.), Input to Output			1500		Vdc
Isolation Voltage, Output to Output			500		Vdc
Isolation Resistance			$10^9$		$\Omega$
Isolation Capacitance			500		pF
Switching Frequency			400		kHz

## ENVIRONMENTAL SPECIFICATIONS

PARAMETER	CONDITION / NOTE	MIN	TYP	MAX	UNIT
Operating Temperature, Industrial (Ambient) <sup>2</sup>	See Figure 1	-40		+71	°C
Operating Temperature, Extended		-55		+85	°C
Storage Temperature Range		-55		+125	°C
Thermal Resistance				7.4	°C/W <sub>DISS</sub>
Maximum Operating Case Temperature				100	°C
Derating	See Figure 1				
Humidity	Up to 95% non-condensing				
Cooling	Free-air convection				
EM/RFI	Six-sided continuous shielded metal case				
MTBF	per MIL-HNBK-217F (Ground benign, +25°C)		1.1×10 <sup>6</sup>		hours

## PHYSICAL CHARACTERISTICS

PARAMETER	CONDITION / NOTE	MIN	TYP	MAX	UNIT
Dimensions (LxWxH)	2.00x1.00x0.395 in. (50.80x25.40x10.03mm)				
Weight	1.06 oz. (30.3g)				
Case Material	Coated metal				
Shielding Connection, 24V <sub>IN</sub>	-Input Ground (Pin 3)				

<sup>1</sup> Measured with 10μF capacitor at the input power pins.

<sup>2</sup> Maximum output current must not exceed 2 amps at either output.

## EXTERNAL SYNCHRONIZATION

The converter can be synchronized to an external TTL or CMOS clock signal. Insert a 470pF to 1000pF ceramic capacitor between the driving clock signal and the SYNC pin (Pin 2) of the converter. The

frequency of the signal must be between 390kHz and 430kHz, with a duty cycle of 50% and an amplitude between 3Vdc minimum and 5Vdc typical. See Application Note DC-005: Synchronization.

## EXTERNAL TRIMMING OF OUTPUT VOLTAGES (SINGLE AND DUAL ONLY)

To trim the output voltage DOWN, connect a 1% 1/8W resistor between the + (plus) output and trim pin of the converter. To trim the output voltage UP, connect a 1% 1/8W resistor between the - (minus) output and trim pins of the converter. For UP/DOWN trimming capability, connect a 10kΩ potentiometer between the + and - output pins, with the wiper arm connected to the trim pin.

The trim resistors/potentiometer can be connected at the converter output pins or the load. However, if connected at the load,

the resistance of the runs becomes part of the feedback network which improves load regulation. If the load is some distance from the converter, the use of #20 gauge wire is recommended to avoid excessive voltage drop due to the resistance of the circuit paths.

See our application notes:

DC-001: Testing Transient Response in DC/DC Converters  
DC-004: Thermal Consideration for DC/DC Converters

**TABLE 1. Minimum input operating voltage range for 24V<sub>IN</sub>**

BD15005	
% FL	Minimum Input Operating Voltage
	24V <sub>IN</sub>
10	7.0
25	8.5
50	8.8
75	9.0
100	9.5

