



BD15002

15W SINGLE DC/DC CONVERTER

$15\text{--}36V_{IN}$, $12V_{OUT}$ @ $1.2A$

Key Features

- 15–36Vdc input voltage range
- Input-to-output isolation
- Soft start
- Short circuit protection
- 150 μ A off state current
- Multiple converter synchronization
- Input overvoltage protection (OVP)
- 180kHz switching frequency
- Six-sided shielding
- Adjustable output



Functional Description

The BD15002 is a 15W single DC/DC converter that features $15\text{--}36V_{IN}$ and $12V_{OUT}$ @ $1.2A$. Its switching frequency of 180kHz allows the converter to be synchronized to an external frequency of 188kHz or higher.

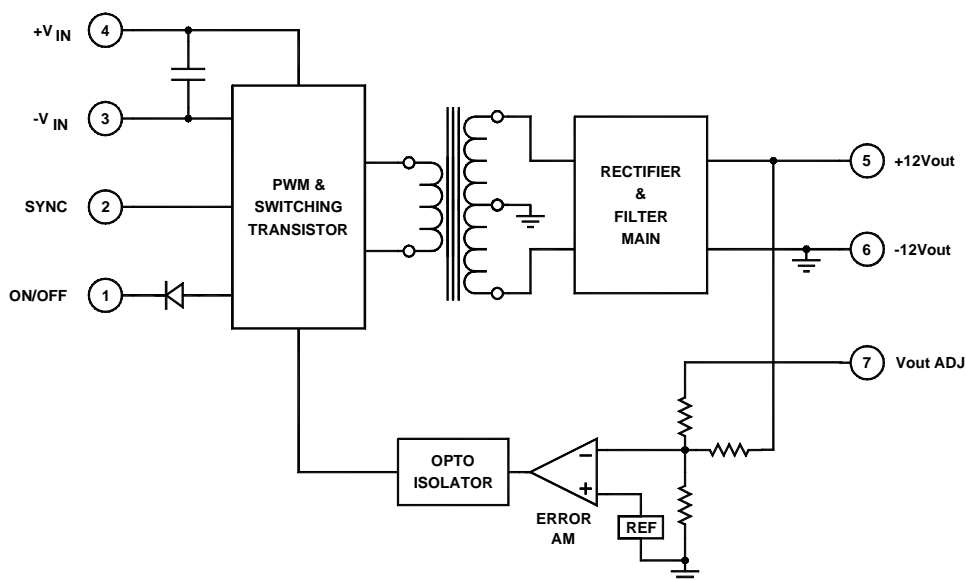

Typical Block Diagram

Electrical Specifications

Unless otherwise specified, all parameters are given under typical +25°C with nominal input voltage and under full output load conditions.

INPUT SPECIFICATIONS

PARAMETER	CONDITION / NOTE	MIN	TYP	MAX	UNIT
Input Voltage Range		15	24	36	Vdc
Input Startup Voltage	No Load	13			Vdc
Undervoltage Shutdown			8		Vdc
Input Filter	π				
Reverse Polarity	External series-blocking diode				
Reflected Ripple	$I_O = 1.2A, C_{IN} = 10\mu F$	80	100	200	mA_{PP}
No Load Input Current			5		mA
Input Surge Current (20 μ S Spike)				10	A
Short Circuit Current Limit			150		% I_{IN}
Off State Current			150		μA
Remote ON/OFF Control					
Supply ON	Pin 1 Open (Open circuit voltage: 12V Max.)				
Supply OFF		0		0.8	Vdc
Logic Input Reference	-Input for ON/OFF and SYNC				
Logic Compatibility	TTL Open Collector or CMOS Open Drain				
Sync, High	See External Synchronization, Figure 3	2		6	Vdc
Sync, Low	See External Synchronization, Figure 3	0		0.8	Vdc

OUTPUT SPECIFICATIONS

PARAMETER	CONDITION / NOTE	MIN	TYP	MAX	UNIT
Output Voltage Accuracy		11.88	12.00	12.12	Vdc
Ripple & Noise	(See App. Note DC-003)		1	2	% V_{PP} of V_{OUT}
Output Current			1.2		A
Line Regulation			± 0.5	± 1	%
Load Regulation			1	2	%
Temperature Coefficient @ FL			0.02		%/ $^{\circ}C$
Transient Response Time	50% FL to FL to 50% FL		100	150	μS
Short Circuit Protection	By input current limiting				
Turn On Delay with Soft Start			2	10	mS
Output Overvoltage Protection	Shunt zener	14	15	17	Vdc
Output Adjust Range		8.5		13.6	Vdc

GENERAL SPECIFICATIONS

PARAMETER	CONDITION / NOTE	MIN	TYP	MAX	UNIT
Efficiency			80		%
Isolation Voltage (1 min.), Input to Output			1500		Vdc
Isolation Resistance			10^9		Ω
Isolation Capacitance			500		pF
Switching Frequency		175	180	230	kHz

ENVIRONMENTAL SPECIFICATIONS

PARAMETER	CONDITION / NOTE	MIN	TYP	MAX	UNIT
Operating Temperature, Industrial (Ambient)	Industrial, See Figure 1	-40		+71	$^{\circ}C$
Storage Temperature Range		-55		+125	$^{\circ}C$
Thermal Resistance	$^{\circ}C$ per watt internally dissipated			7.4	$^{\circ}C/W_{DISS}$
Maximum Operating Case Temperature				100	$^{\circ}C$
Derating	See Figure 1				
Humidity	Up to 95% non-condensing				
Cooling	Free-air convection				
EM/RFI	Six-sided continuous shielded metal case				
MTBF	per MIL-HNBK-217F (Ground benign, +25 $^{\circ}C$)		1.1×10^6		hours

PHYSICAL CHARACTERISTICS

PARAMETER	CONDITION / NOTE	MIN	TYP	MAX	UNIT
Dimensions (LxWxH)	2.00x1.00x0.395 in. (50.80x25.40x10.03mm)				
Weight	1.06 oz. (30.3g)				
Case Material	Coated metal				
Shielding Connection	-Input Ground (Pin 3)				

EXTERNAL TRIMMING OF OUTPUT VOLTAGES (SINGLE AND DUAL ONLY)

To trim the output voltage DOWN, connect a 5% ¼W resistor between the + (plus) output and trim pin of the converter. To trim the output voltage UP, connect a 5% ¼W resistor between the – (minus) output and trim pins of the converter. For UP/DOWN trimming capability, connect a 10kΩ potentiometer between the + and – output pins, with the wiper arm connected to the trim pin.

The trim resistors/potentiometer can be connected at the converter output pins or the load. However, if connected at the load, the

resistance of the runs becomes part of the feedback network which improves load regulation. If the load is some distance from the converter, the use of #20 gauge wire is recommended to avoid excessive voltage drop due to the resistance of the circuit paths.

See our application notes:

DC-001: Testing Transient Response in DC/DC Converters

DC-004: Thermal Consideration for DC/DC Converters

EXTERNAL SYNCHRONIZATION

A TTL signal applied at the SYNC pin of the converter will synchronize the switching frequency of the converter to that of the TTL input signal. The external (TTL) frequency must be equal or higher than the converter's frequency. At the positive-going edge of the applied pulse, the internal power-switching transistor turns off and the PWM discharges its timing capacitor. At the negative-going edge, the PWM resumes normal operation. The minimum positive

pulse width of the TTL signal must be 300nS minimum and its frequency between 180kHz and 200 kHz. NOTE: Higher frequencies will reduce the efficiency of the converter and wide TTL pulses will force the PWM to follow the external TTL width modulation, which may effect regulation. A high TTL signal at the SYNC pin of the converter will turn the converter off. An internal pull-down resistor will keep this pin low when it is not used.

TABLE 1. Minimum input operating voltage range

BD15002	
% FL	Minimum Input Operating Voltage
	24V _{IN}
10	12.0
25	13.5
50	14.0
75	14.5
100	15.0

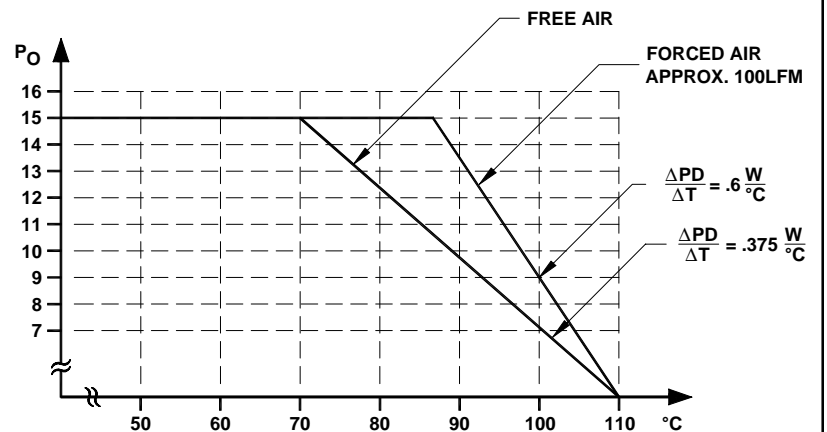
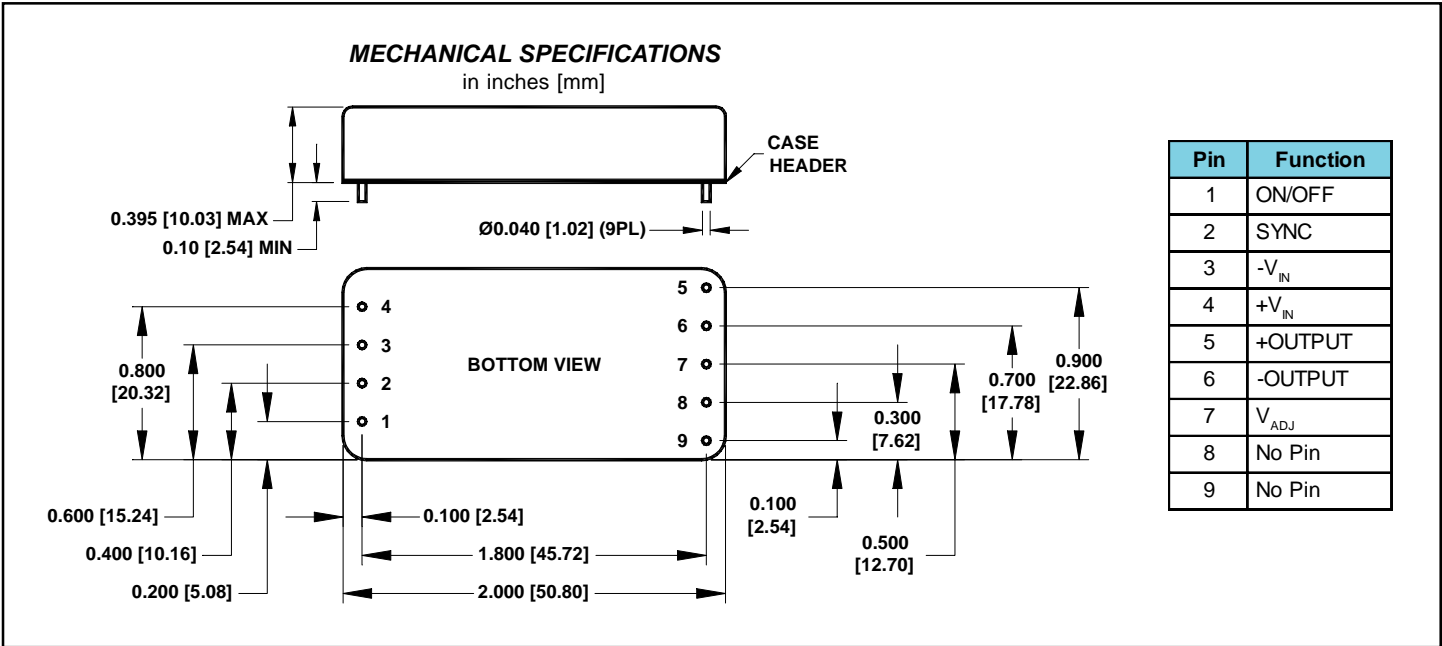
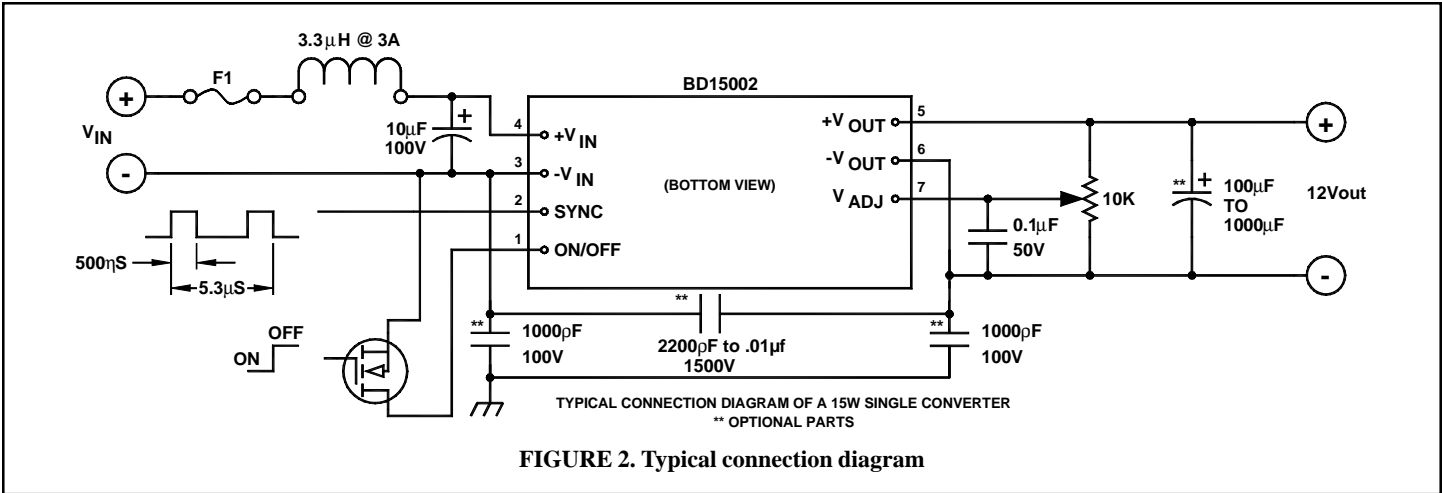

FIGURE 1. Worst case derating of BD15002



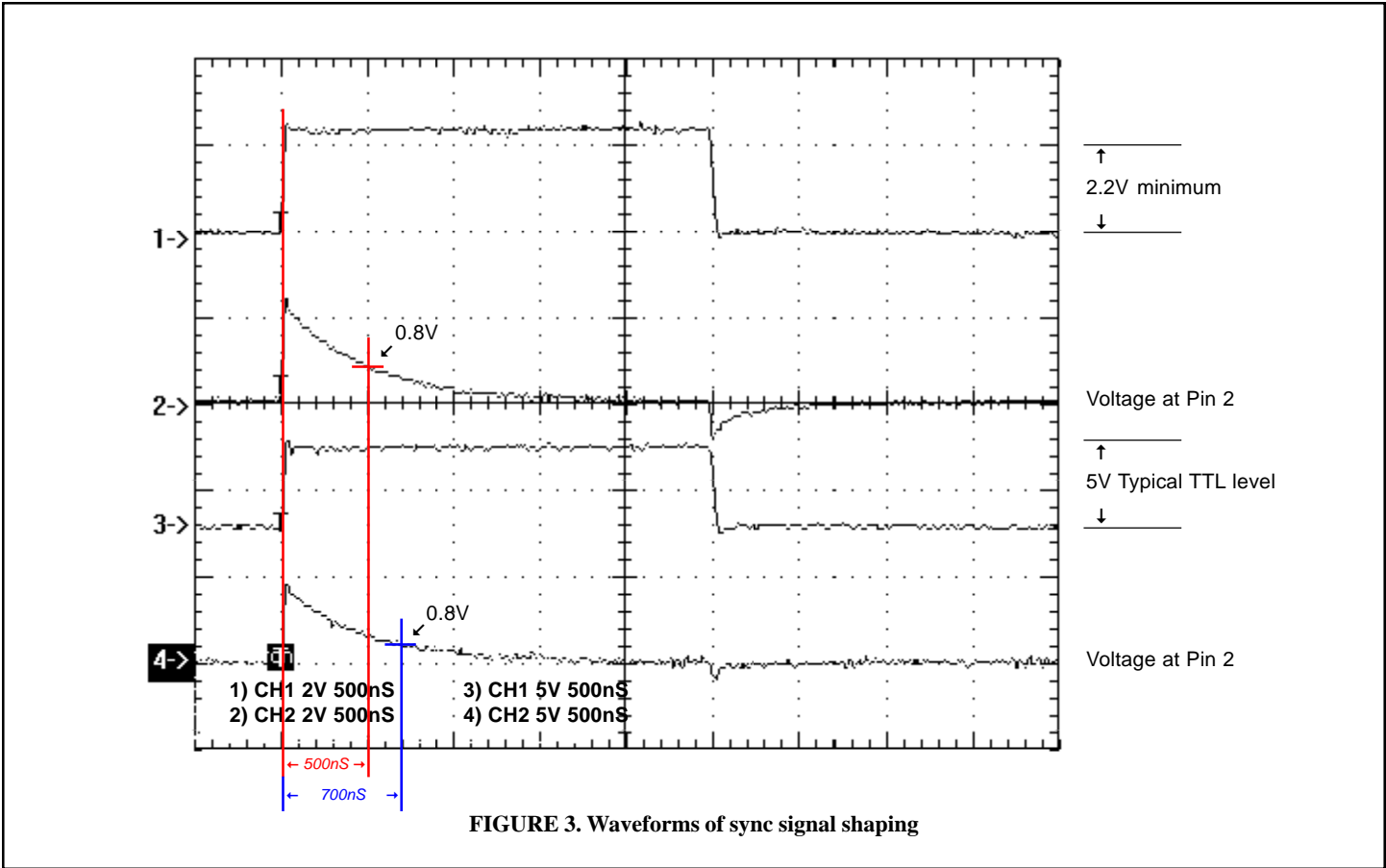

FIGURE 3. Waveforms of sync signal shaping

SYNC SIGNAL SHAPING

As described in External Synchronization, the PWM of the converter requires a TTL signal of 0.8 to 2Vdc minimum amplitude and minimum duration of 300nS. When such a signal is not available (through one shot multivibrator or other pulse-shaping circuits) a C-R differentiator can be used to shape a square wave TTL signal, such as the one shown in Figure 4.

As is shown by the oscillogram in Figure 3, the positive edge of the sync pulse must be 2V minimum and the decaying exponential must reach the low 0.8Vdc in 300nS minimum from the positive edge. The parallel diode with the resistor is a small signal switching diode or a Schottky signal diode with 0.3 to 0.5V forward drop, it is used to clamp the voltage at pin 2 @ -0.5Vdc.

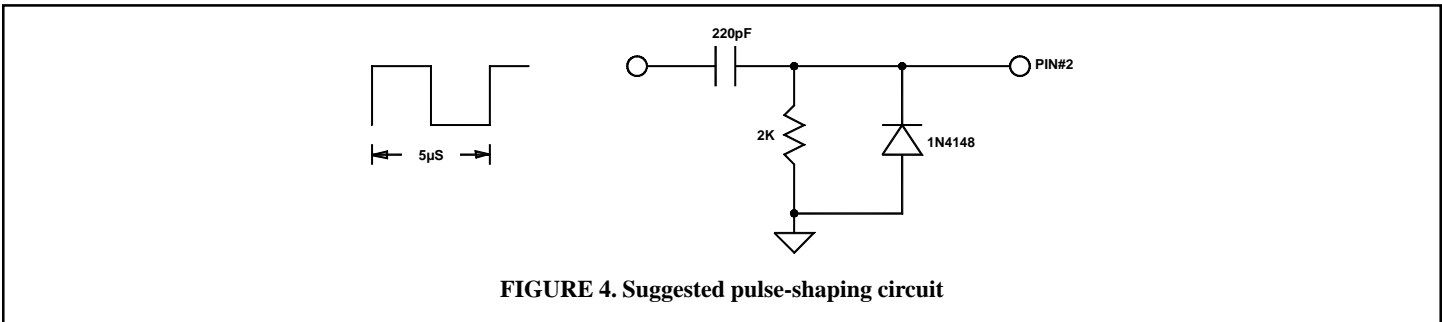

FIGURE 4. Suggested pulse-shaping circuit