



BD150000

150W HIGH-VOLTAGE DC/DC CONVERTER
2000Vdc Isolation

Key Features

- 93% efficiency
- 2000Vdc input-to-output isolation
- Input undervoltage protection
- Output undervoltage protection
- Soft start
- Adjustable output
- 300kHz switching frequency
- Thermal protection
- Six-sided shielding



Functional Description

The BD150000 is a 150W high-voltage isolated DC/DC converter that accepts $24V_{IN} \pm 10\%$ and produces a regulated $75V_{OUT} @ 2A$ at its output with an adjustable range of $\pm 5\%$. A high switching frequency of 300kHz, SMD, and thermal management improve efficiency and reliability. The converter is designed and thoroughly tested for an input-to-output isolation of 2000Vdc.

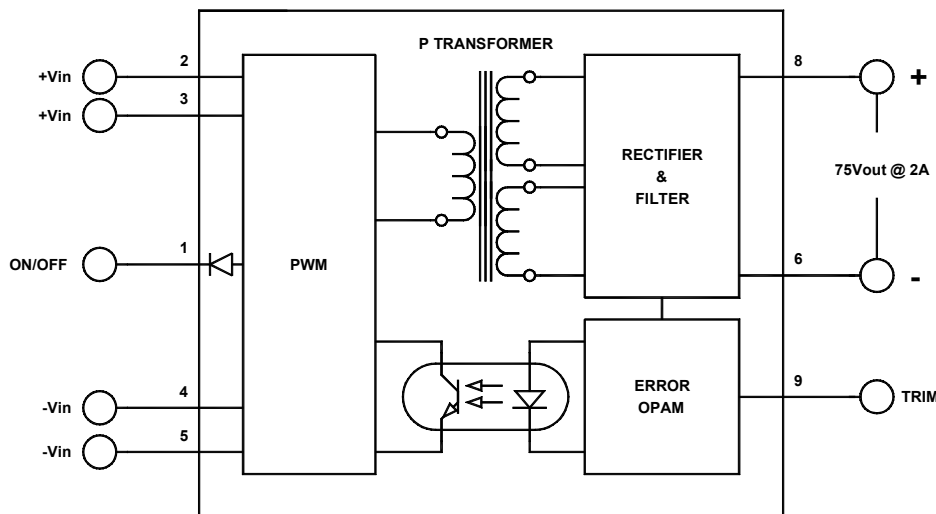

Typical Block Diagram

Electrical Specifications

Unless otherwise specified, all parameters are given under typical +25°C with nominal input voltage and under full output load conditions.

INPUT SPECIFICATIONS

PARAMETER	CONDITION / NOTE	MIN	TYP	MAX	UNIT
Input Voltage Range		22.8	24	26	Vdc
Input Startup Voltage		15			Vdc
Input Filter	C				
Reverse Polarity	External series-blocking diode				
Reflected Ripple ¹	$I_o = FL, C_{IN} = 100\mu F$, See Figure 3		100		mA _{PP}
No Load Input Current			40		mA
Full Load Input Current ²	Nominal line and Full load		6700		mA
Input Surge Current (20 μ S Spike)				10	A
Short Circuit Current Limit	Hiccup, See Figure 3		150		% I_{IN}
Off State Current			1		mA
Remote ON/OFF Control					
Supply ON	Pin 1 Open (Open circuit voltage: 13V max.)				
Supply OFF		0		0.8	Vdc
Logic Input Reference	-Input for ON/OFF				
Logic Compatibility for Reference	TTL Open Collector or CMOS Open Drain				

OUTPUT SPECIFICATIONS

PARAMETER	CONDITION / NOTE	MIN	TYP	MAX	UNIT
Output Voltage			75		Vdc
Output Voltage Accuracy	See formulas for RT in Figure 1B		± 1	± 2	%
Output Current			2000		mA
Ripple & Noise	(See App. Note DC-003)		1	2	%V _{PP} of V _{OUT}
Line Regulation			± 0.5	± 1	%
Load Regulation			± 1	± 2	%
Output Overvoltage Protection			86		Vdc
Temperature Coefficient @ FL			0.02		%/°C
Transient Response Time (to within 1% of V _O)	50% FL to FL to 50% FL, See Figure 4		100		μ S
Short Circuit Protection	By input current limiting				
Output Adjust Range	See Figure 1B, (See App. Note DC-010)		± 5		%

GENERAL SPECIFICATIONS

PARAMETER	CONDITION / NOTE	MIN	TYP	MAX	UNIT
Efficiency			93		%
Isolation Voltage (1 min.), Input to Output	100% Tested in production	2000			Vdc
Isolation Resistance			10 ⁹		Ω
Isolation Capacitance			2700		pF
Switching Frequency			300		kHz
Turn On Delay	See Figure 5		7	10	mS
Soft Start Time	See Figure 5		7	15	mS

PHYSICAL CHARACTERISTICS

PARAMETER	CONDITION / NOTE	MIN	TYP	MAX	UNIT
Dimensions (L×W×H)	3.00×2.56×0.75 in. (76.20×65.02×19.05mm)				
Weight	7.87 oz. (223g)				
Case Material	Black coated copper				
Shielding Connection, 24V _{IN}	-V _N (Pins 4 & 5)				

ENVIRONMENTAL SPECIFICATIONS

PARAMETER	CONDITION / NOTE	MIN	TYP	MAX	UNIT
Operating Temperature Range (Ambient)*	See Figure 2	-40		+70	°C
Storage Temperature Range		-55		+125	°C
Thermal Resistance	°C per watt internally dissipated		2.5	3	°C/W _{DISS}
Maximum Operating Case Temperature				110	°C
Derating	See Figure 2				
Cooling	Free-air convection				
EM/RFI	Six-sided continuous shielded metal case				
MTBF	per MIL-HNBK-217F (Ground benign, +25°C)		400,000		hours
Humidity	Up to 95% non-condensing				
Thermal Shutdown	Case Temperature		110	115	°C
Thermal Hysteresis			25	35	°C

* See footnotes 3 and 4.

¹ Measured with 100µF capacitor at the input power pins.

² The maximum input current at any given input range measured at minimum input voltage is given as $1.6 \cdot I_{\text{NOMINAL}}$. Nominal input current is the typical value measured at the input of the converter under full-load room temperature and nominal input voltage (24Vdc).

³ Adequate insulation is to be provided to the converters at the end usage as per applicable requirements.

⁴ Temperature rise on the case of the converters is to be considered during the end usage as per applicable requirements.

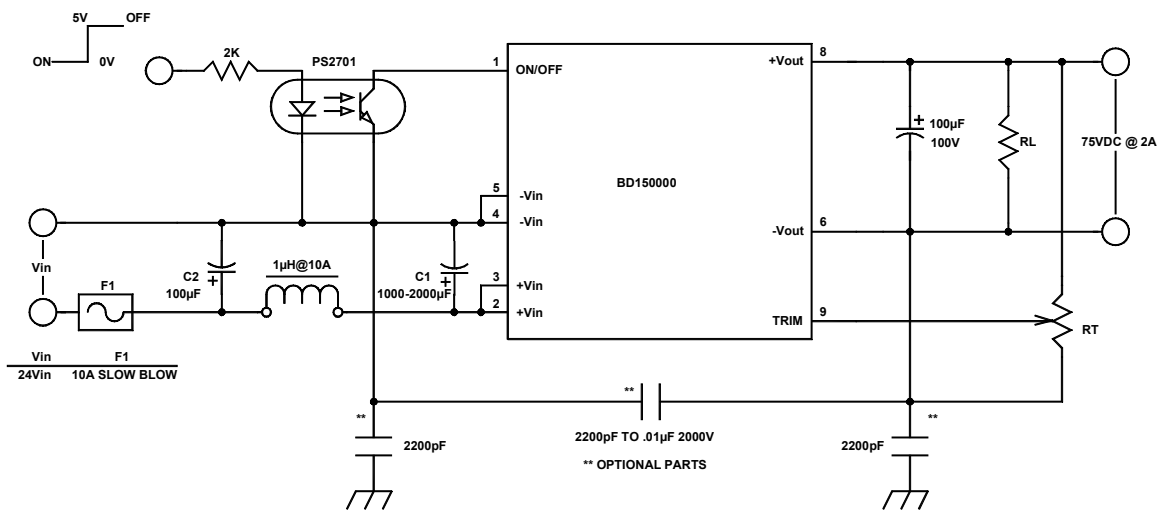

FIGURE 1A. Typical connection diagram

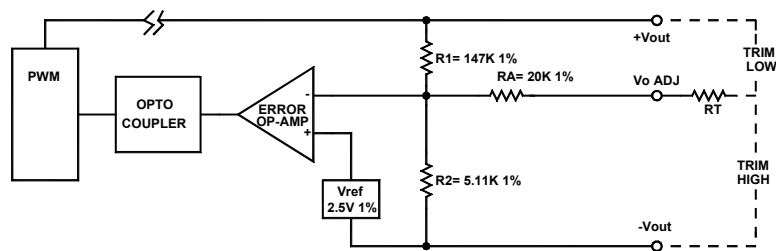

FIGURE 1B. Output control circuit

To trim V_o higher to V_o' , where V_o is the actual nominal measured value:

$$RT = \frac{R1 \cdot V_{REF}}{V_o' - V_o} \quad \text{For the above given values: } RT = \frac{3 \cdot 10^6}{V_o' - V_o} - 30.1k$$

To trim V_o lower to V_o'' , where V_o is the actual measured value:

$$RT = \left[\left(\frac{R_1 \cdot 2 \cdot V_{REF}}{R_2 (V_o - V_o'')} - R1 \right) - 30.1k \right]$$

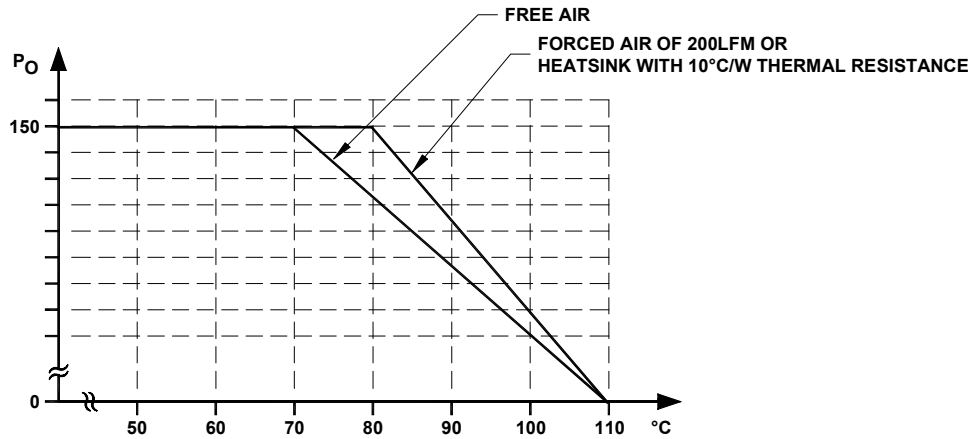

FIGURE 2. Typical derating curves

EXTERNAL TRIMMING OF OUTPUT VOLTAGES

To trim the output voltage DOWN, connect a 5% ¼W 1.5MΩ resistor (DO NOT GO BELOW 1MΩ) between the +V_{O1} (Pin 8) output and trim pin of the converter. To trim the output voltage UP, connect a 5% ¼W resistor between the -V_{O1} (Pin 6) output and trim pins of the converter. For UP/DOWN trimming capability, connect a 2MΩ potentiometer between the + and - output pins, with the wiper arm connected to the trim pin.

The trim resistors/potentiometer can be connected at the con-

verter output pins or the load. However, if connected at the load, the resistance of the runs becomes part of the feedback network which improves load regulation. If the load is some distance from the converter, the use of #20 gauge wire is recommended to avoid excessive voltage drop due to the resistance of the circuit paths. See our application notes:

- DC-001: Testing Transient Response in DC/DC Converters
- DC-004: Thermal Consideration for DC/DC Converters

MECHANICAL SPECIFICATIONS

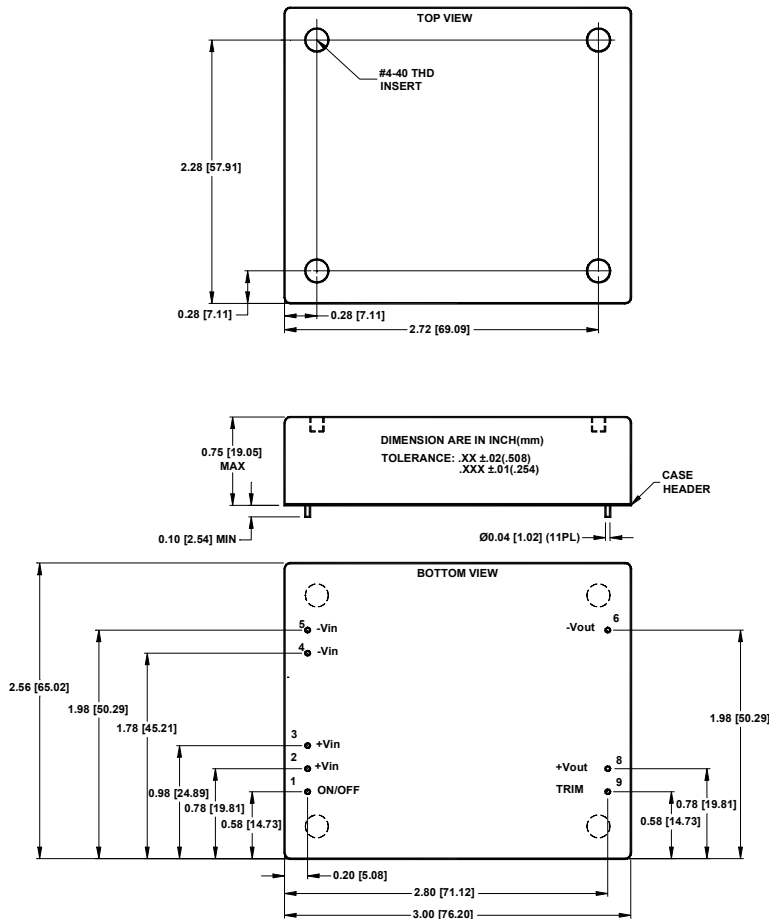

Pin	Function
	SINGLE
1	ON/OFF
2	+V _{IN}
3	+V _{IN}
4	-V _{IN}
5	-V _{IN}
6	-V _{OUT}
7	No Pin
8	+V _{OUT}
9	V _{OUT} ADJ

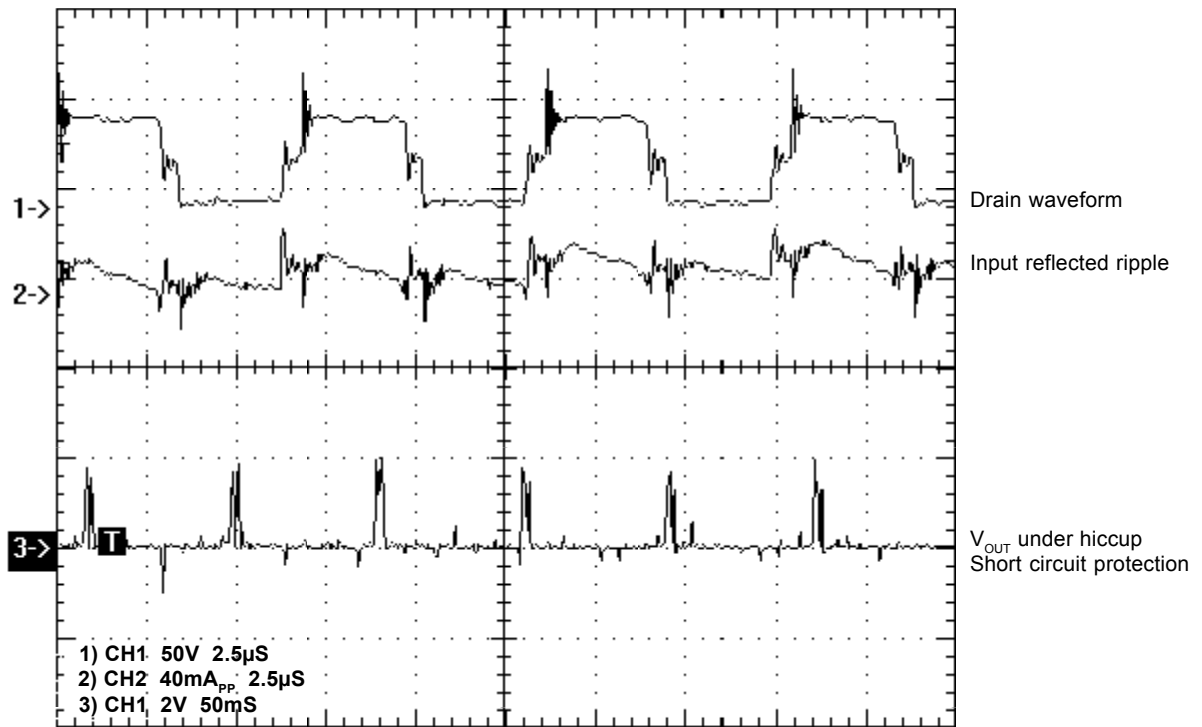

FIGURE 3. Reflected ripple and V_{OUT} under hiccup

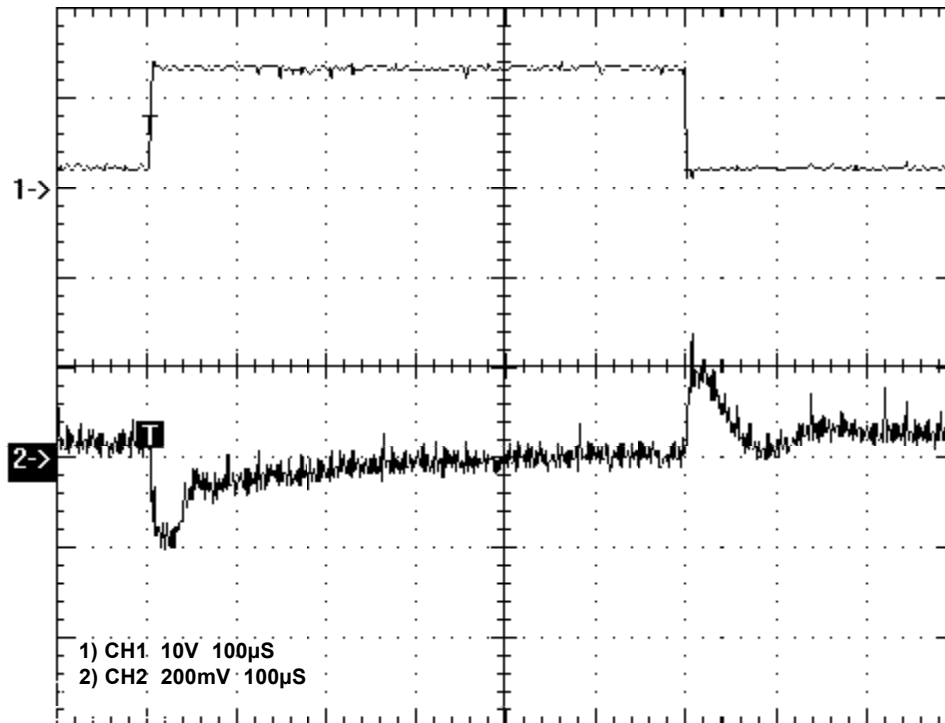

FIGURE 4. Transient response 60% FL to FL to 60% FL
 with C_{IN}=1000μF 35V, C_O=10μF 100V ceramic

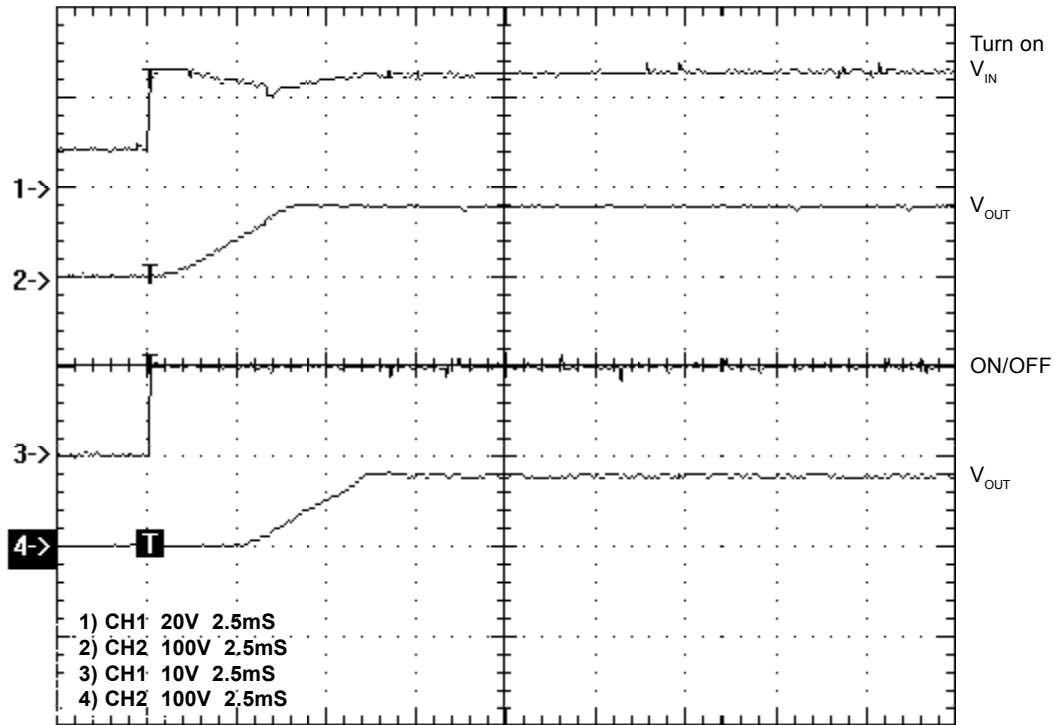

FIGURE 5. Turn on delay with soft start