



BD10020

10W SINGLE DC/DC CONVERTER

$48V_{OUT}$

Key Features

- 89% efficiency
- Input-to-output isolation
- Wide input voltage range (18–36Vdc)
- Soft start
- Input LC filter
- Short circuit and thermal protection
- EMI six-sided shielding
- External sync
- On/Off



Functional Description

The BD10020 is a 10W single DC/DC converter in a 2x1x0.395-inch package that accepts $24V_{IN}$ and provides $48V_{OUT}@210mA$ with an operating temperature range from $-40^{\circ}C$ to $+71^{\circ}C$.

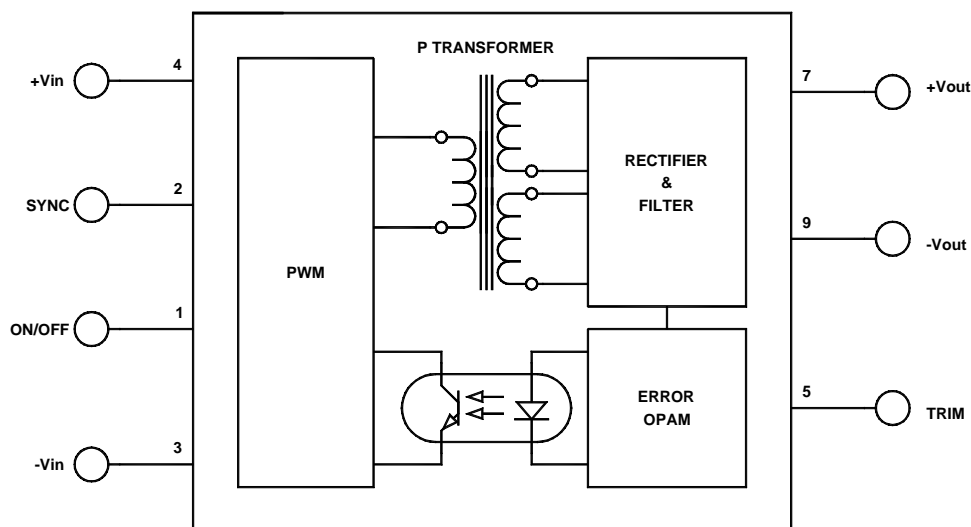

Typical Block Diagram

Electrical Specifications

Unless otherwise specified, all parameters are given under typical +25°C with nominal input voltage and under full output load conditions.

INPUT SPECIFICATIONS

PARAMETER	CONDITION / NOTE	MIN	TYP	MAX	UNIT
Input Voltage Range		18	24	36	Vdc
No Load Input Current			10		mA
Full Load Input Current			470		mA
Input Filter	LC				
Reflected Ripple Current	Measured with 10 μ F input capacitor		100		mA _{PP}
Reverse Voltage Protection	Parallel Diode		5		A
On/Off	Reference to -V _{IN}				
Voltage	Open		10		Vdc
Turn On Delay	Including soft start, See Figure 2		2.5		mS
Startup Input Voltage		11	16		Vdc

OUTPUT SPECIFICATIONS

PARAMETER	CONDITION / NOTE	MIN	TYP	MAX	UNIT
Output Voltage			48		Vdc
Output Voltage Accuracy			1	2	%
Output Current			210		mA
Ripple & Noise (20MHz BW)			1	2	% of V _{OUTPP}
Line Regulation	Outputs fully loaded		1		%
Load Regulation	10% FL to FL		1		%
Temperature Coefficient @ FL			± 0.02		%/ $^{\circ}$ C
Short Circuit Protection	Continuous, Input Current Limit				
Short Circuit Restart	Automatic				
Transient Response (to within 1% of V _{OUT})	50% FL to 100% FL to 50% FL, See Figure 2		300		μ S

GENERAL SPECIFICATIONS

PARAMETER	CONDITION / NOTE	MIN	TYP	MAX	UNIT
Efficiency			89		%
Isolation Voltage (1 min.)		500	1000		Vdc
Isolation Resistance			10 ⁹		Ω
Isolation Capacitance			300		pF
Switching Frequency			300		kHz

ENVIRONMENTAL SPECIFICATIONS

PARAMETER	CONDITION / NOTE	MIN	TYP	MAX	UNIT
Operating Temperature Range (Ambient)		-40		+70	$^{\circ}$ C
Storage Temperature Range		-60		+125	$^{\circ}$ C
Derating	See Figure 4				
Humidity	Up to 95% non-condensing				
Cooling	Free-air convection				
MTBF	per MIL-HNBK-217F (Ground benign, +25 $^{\circ}$ C)		1.2 $\times 10^6$		hours

PHYSICAL CHARACTERISTICS

PARAMETER	CONDITION / NOTE	MIN	TYP	MAX	UNIT
Dimensions (LxWxH)	2.00x1.00x0.395 in. (50.80x25.40x10.03mm)				
Weight	1.04 oz. (30g)				
Case Material	Coated metal				
Shielding	Six-sided continuous				
Case Connection	-V _N (Pin 3)				

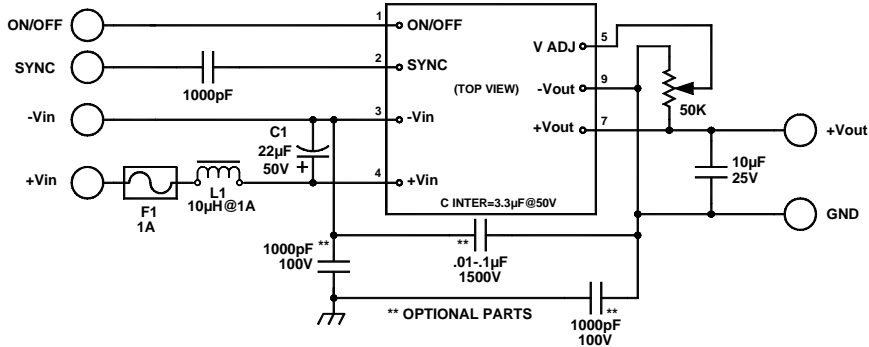

FIGURE 1. Connection diagram

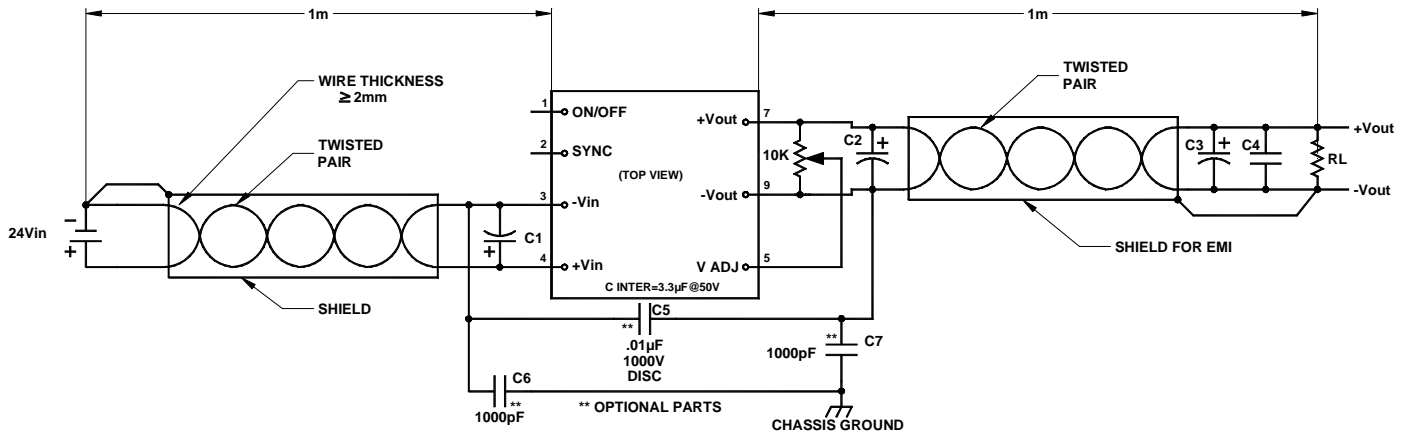

FIGURE 2. Connection diagram

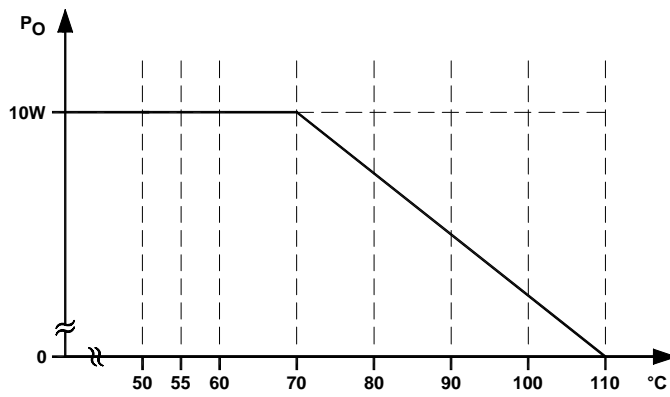

FIGURE 3. Derating of BD10020

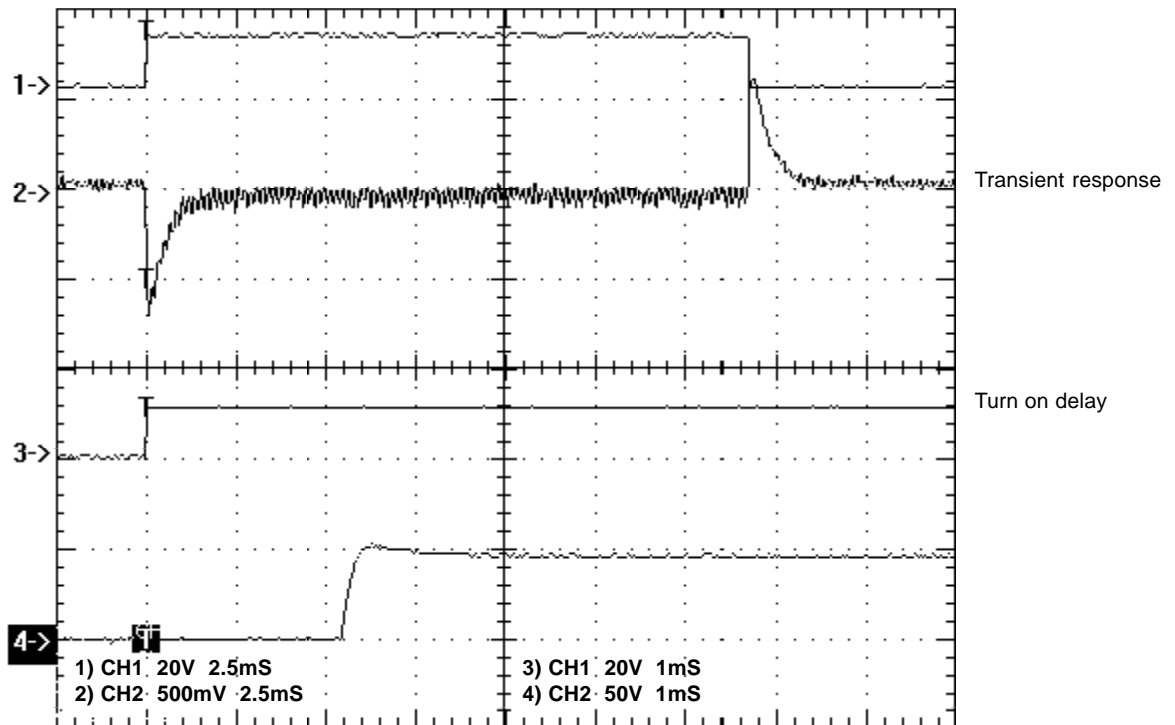

FIGURE 4. Transient response and turn on delay with soft start

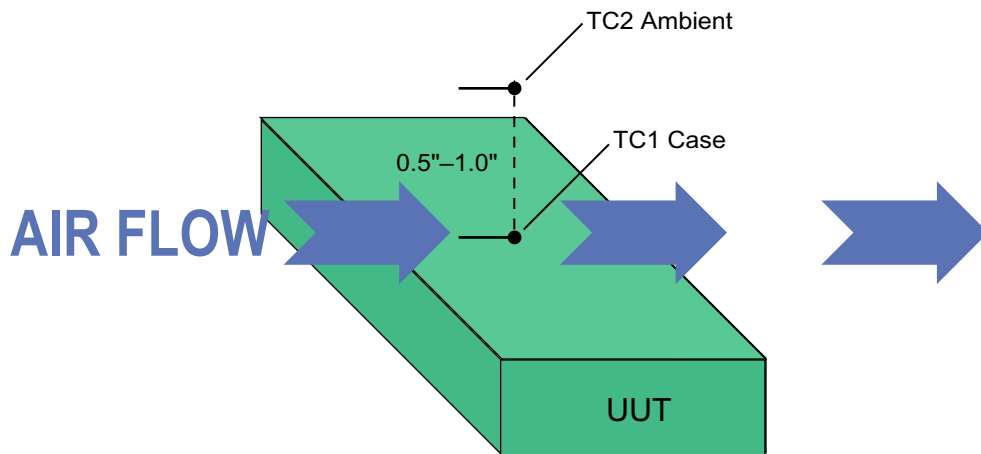
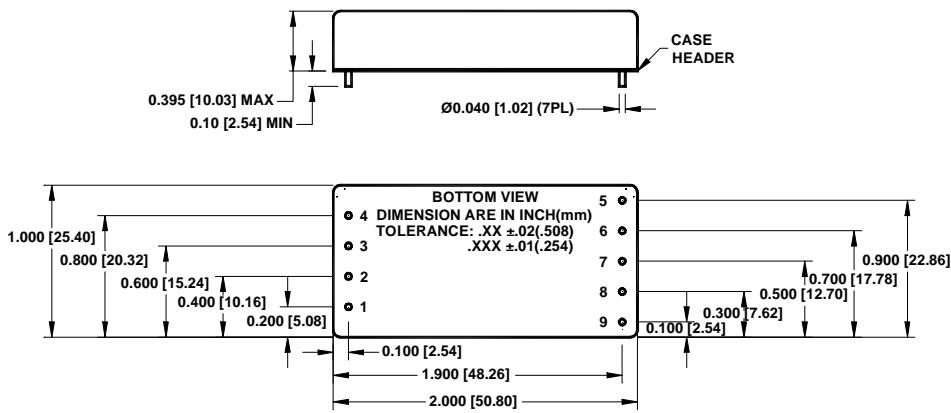

FIGURE 5. Setup for measuring case and ambient temperatures

The ambient temperature is measured with thermo-coupler #2, which is positioned 0.5"-1.0" above the center of the unit. When airflow is used, position the converter such that the 2" length of the converter is perpendicular to the airflow.

MECHANICAL SPECIFICATIONS



Pin	Function
	SINGLE
1	ON/OFF
2	SYNC
3	-V _{IN}
4	+V _{IN}
5	V _{OUT} ADJ
6	No Pin
7	+V _{OUT}
8	No Pin
9	-V _{OUT}

OUTPUT VOLTAGE ADJUSTMENT

For both single and dual models, the output reference voltage is referenced to the output ground: Pin 6 for singles and Pin 8 for duals. To trim the output voltage high, connect a 1% resistor (0kΩ–200kΩ range) between -V_{OUT} (Pin 6) and V_{OUT} Adjust (Pin 9) for the singles, and COM (Pin 8) and V_{OUT} Adjust (Pin 5) for the duals. To trim the output voltage low, connect a 1% resistor (50kΩ–500kΩ range) between +V_{OUT} (Pin 5) and V_{OUT} Adjust (Pin 9) for

the singles, and +V_{OUT} (Pin 7) and V_{OUT} Adjust (Pin 5) for the duals.

With the wiper connected to the V_{OUT} Adjust pin, a variable resistor (potentiometer) can also be used for V_{OUT} adjustment by connecting each end to +V_{OUT} and -V_{OUT} for the singles, and +V_{OUT} and COM for the duals. A potentiometer between 50kΩ–100kΩ can be used. Avoid using a low resistance potentiometer or a high temperature coefficient such as wound wire.

EXTERNAL SYNCHRONIZATION

This series of converters can be synchronized to an external system clock of 320kHz -2% to 10%. The external clock is AC-coupled to the input SYNC terminal (Pin 2) through a coupling

capacitor from 220pF to 1000pF. The required amplitude is 3.3V to 5V and its duty cycle is 50% ±20%. Please refer to *Application Note DC-005: Synchronization* for more information.