



BD10017

10W TRIPLE DC/DC CONVERTER

6:1 Input Voltage Range

Key Features

- Input-to-output isolation
- Soft start
- Input LC filter
- Short circuit and thermal protection
- Wide 6:1 input voltage range (36–210Vdc)
- EMI six-sided shielding



Functional Description

The BD10017 is a 10W Triple DC/DC Converter in a 2x1x0.395-inch package that provides $5V_{OUT}@1.6A$, $1.8V_{OUT}@0.9A$ and $3.3V_{OUT}@100mA$ with an operating temperature range from $-25^{\circ}C$ to $+60^{\circ}C$. The main $5V_{OUT}$ is isolated from input to output and from the other two outputs. The converter requires a minimum load at its main output.

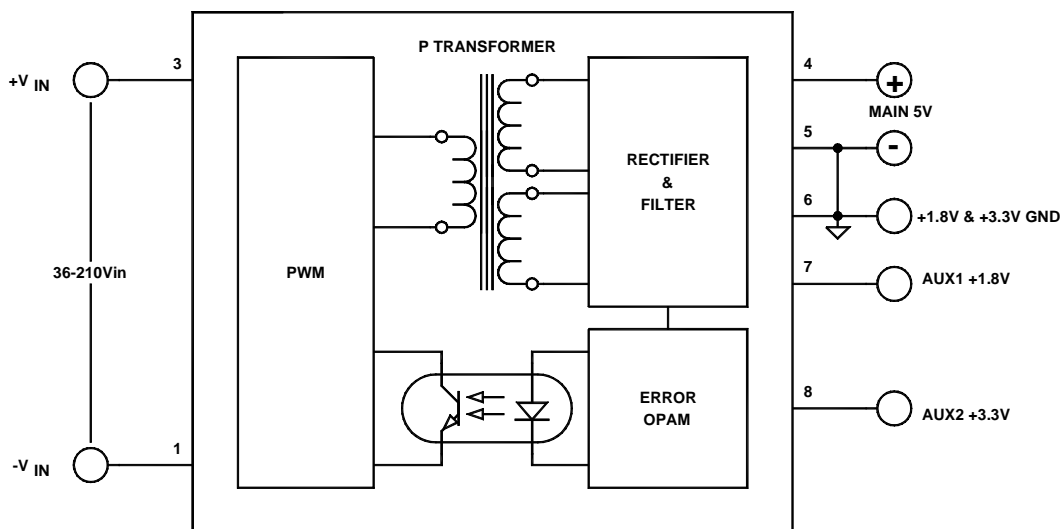

Typical Block Diagram

Electrical Specifications

Unless otherwise specified, all parameters are given under typical +25°C with nominal input voltage and under full output load conditions.

INPUT SPECIFICATIONS

PARAMETER	CONDITION / NOTE	MIN	TYP	MAX	UNIT
Input Voltage Range		36	120	210	Vdc
Input Voltage Slew Rate				10	V/μS
No Load Input Current	@120Vdc		20		mA
Full Load Input Current	@120Vdc		110		mA
Input Filter	LC				
Reflected Ripple Current	Measured with 10μF input capacitor, See Figure 2		100		mA _{PP}
Reverse Voltage Protection	Parallel Diode		5		A
On/Off	Reference to -V _{IN}				
Voltage	Open		10		Vdc
Turn On Delay	Including soft start, See Figure 3		25	35	mS
Startup Input Voltage		11	16		Vdc

OUTPUT SPECIFICATIONS

PARAMETER	CONDITION / NOTE	MIN	TYP	MAX	UNIT
5V OUTPUT (MAIN)					
Output Voltage Accuracy			1		%
Output Current			1.6		A
Ripple & Noise (20MHz BW)			1	4	% of V _{OUTPP}
Line Regulation	Outputs fully loaded		1		%
Load Regulation	10% FL to FL		1		%
OVP			6.8		Vdc
1.8V OUTPUT (AUX1)					
Output Voltage Accuracy			5		%
Output Current			900		mA
Ripple & Noise (20MHz BW)			2	4	% of V _{OUTPP}
Line Regulation	Outputs fully loaded		5		%
Load Regulation	10% FL to FL, Main fully loaded		5		%
OVP			2.5		Vdc
3.3V OUTPUT (AUX2)					
Output Voltage Accuracy			5		%
Output Current			100		mA
Ripple & Noise (20MHz BW)			2	5	% of V _{OUTPP}
Line Regulation	Outputs fully loaded		5		%
Load Regulation	10% FL to FL, Main fully loaded		5		%
OVP			5.2		Vdc
Temperature Coefficient @ FL			±0.02		%/°C
Short Circuit Protection	Continuous, Current Limit				
Short Circuit Restart	Automatic				
Transient Response (to within 1% of V _{OUT})	50% FL to 100% FL to 50% FL, See Figure 5		100	250	μS

GENERAL SPECIFICATIONS

PARAMETER	CONDITION / NOTE	MIN	TYP	MAX	UNIT
Efficiency			75		%
Isolation Voltage (1 min.)		500	1000		Vdc
Isolation Resistance			10 ⁹		Ω
Isolation Capacitance			300		pF
Switching Frequency		108	125	130	kHz

ENVIRONMENTAL SPECIFICATIONS

PARAMETER	CONDITION / NOTE	MIN	TYP	MAX	UNIT
Operating Temperature Range (Ambient)		-25		+60	°C
Storage Temperature Range		-60		+125	°C
Derating	See Figure 7				
Thermal Protection, Turn Off ¹	Junction Temperature		145		°C
Thermal Hysteresis			30		°C
Humidity	Up to 95% non-condensing				
Cooling	Free-air convection				
MTBF	per MIL-HNBK-217F (Ground benign, +25°C)		TBD		hours

PHYSICAL CHARACTERISTICS

PARAMETER	CONDITION / NOTE	MIN	TYP	MAX	UNIT
Dimensions (LxWxH)	2.00x1.00x0.395 in. (50.80x25.40x10.03mm)				
Weight	1.04 oz. (30g)				
Case Material	Coated metal				
Shielding	Six-sided continuous				
Case Connection	-V _{IN} (Pin 1)				

¹ The input power may have to be recycled after thermal turn off.

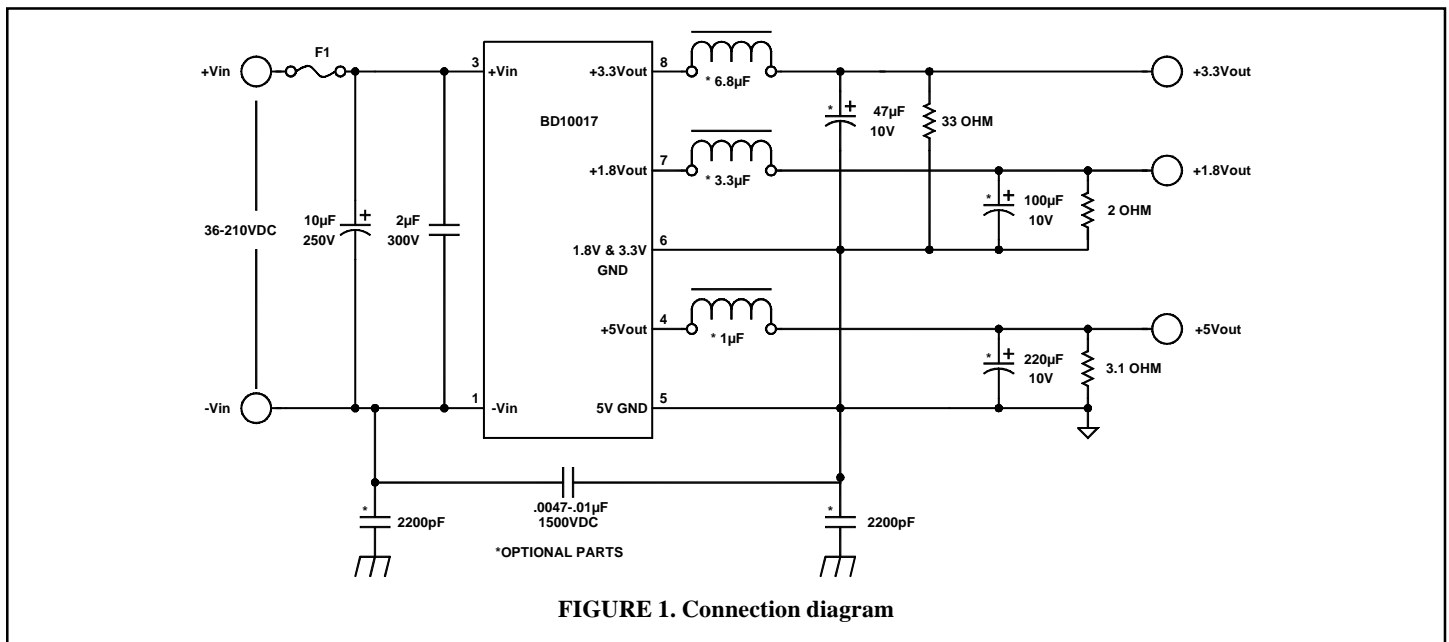

MECHANICAL SPECIFICATIONS

in inches [mm]

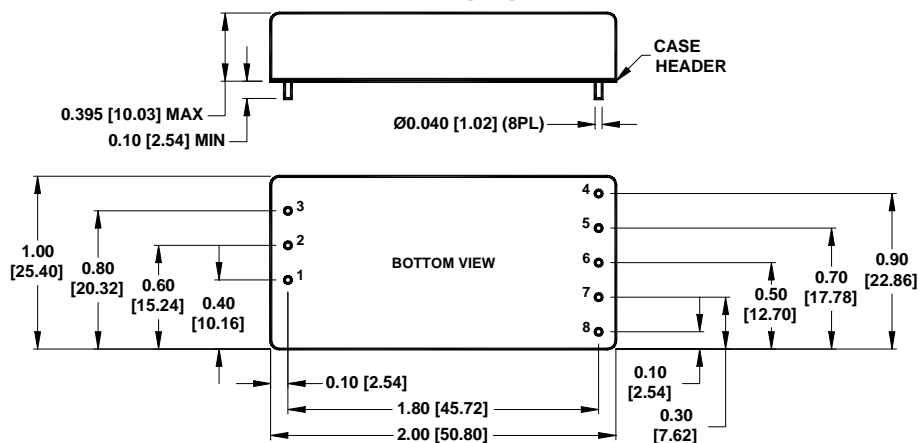

Pin	Function
1	-V _{IN}
2	No Pin
3	+V _{IN}
Triple Output	
4	MAIN +5V _{OUT}
5	MAIN -5V _{OUT}
6	GND
7	AUX1 +1.8V _{OUT}
8	AUX2 +3.3V _{OUT}

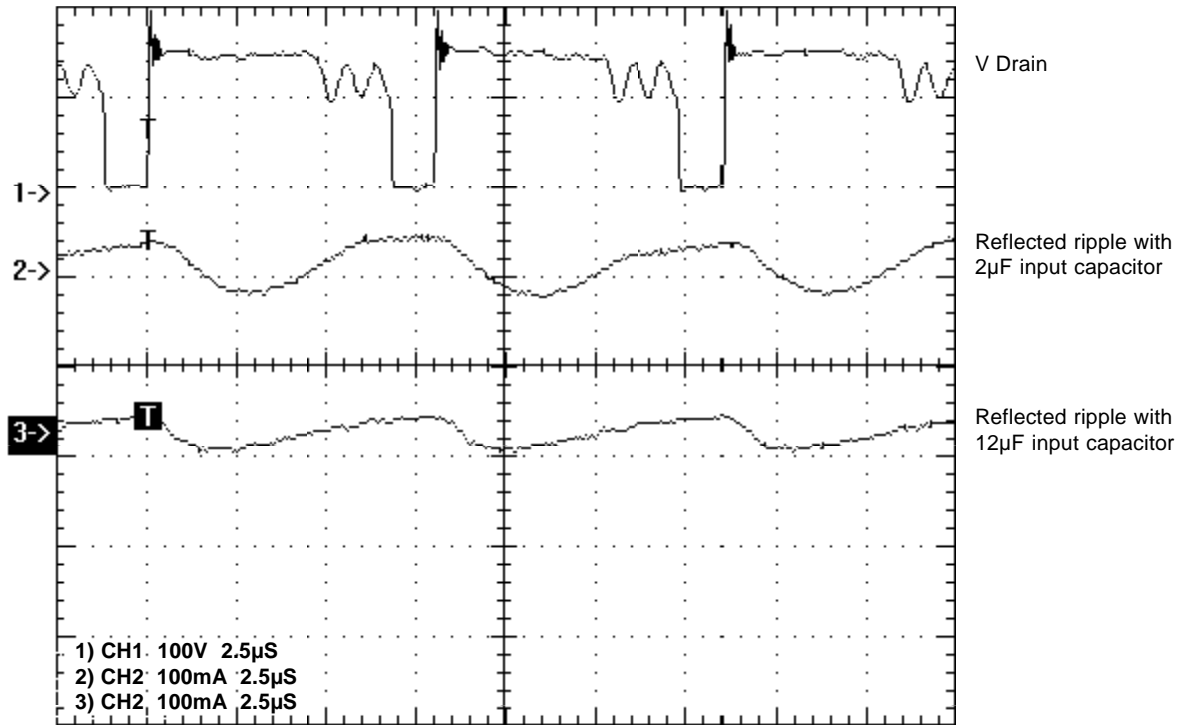

FIGURE 2. Reflected ripple with 2µF and 12µF input capacitors

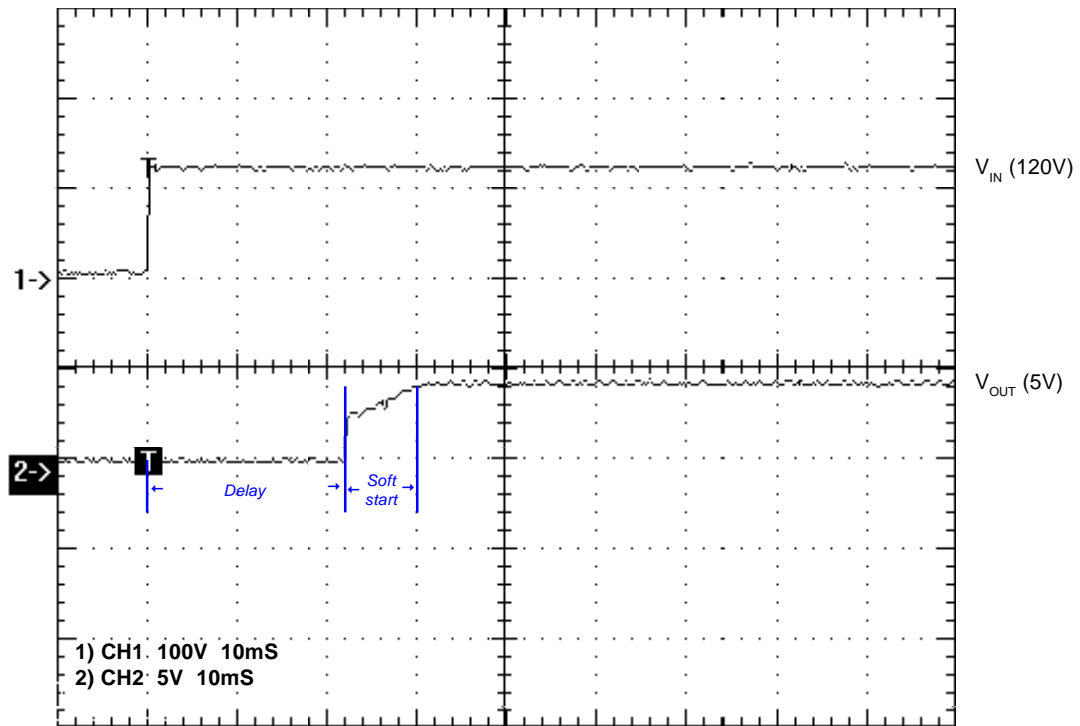

FIGURE 3. Turn on delay with soft start

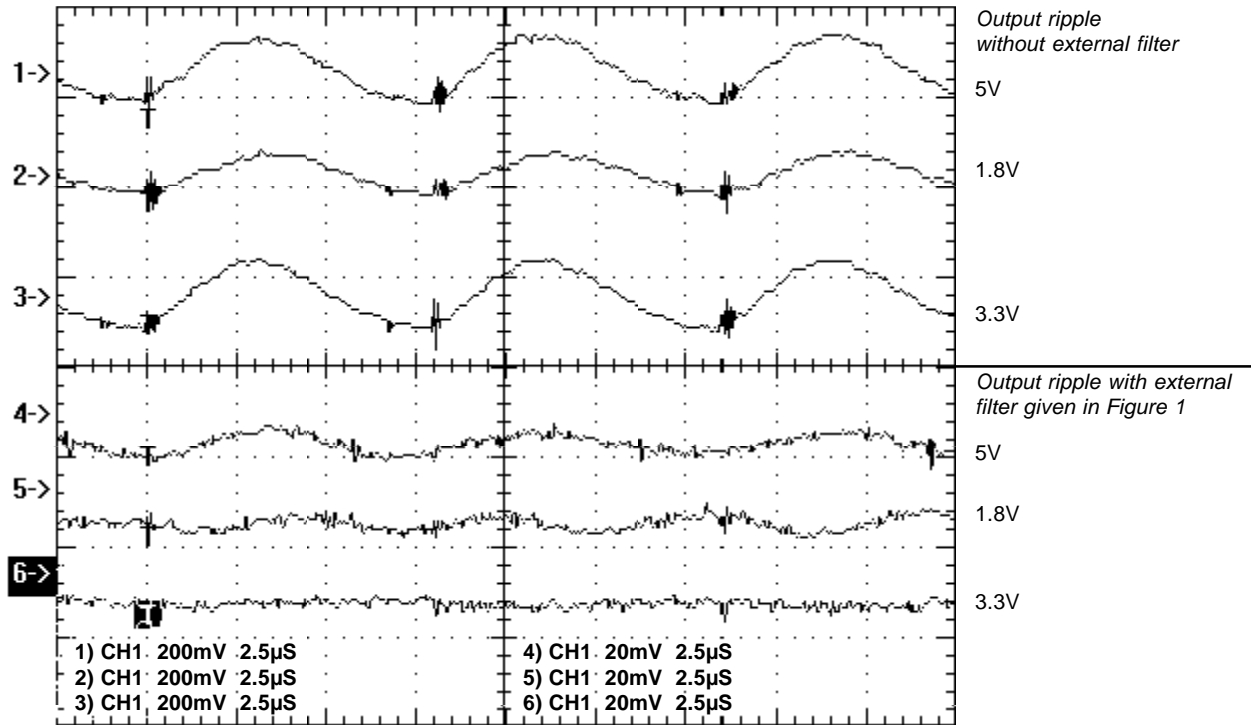

FIGURE 4. Output ripple without and with external filter

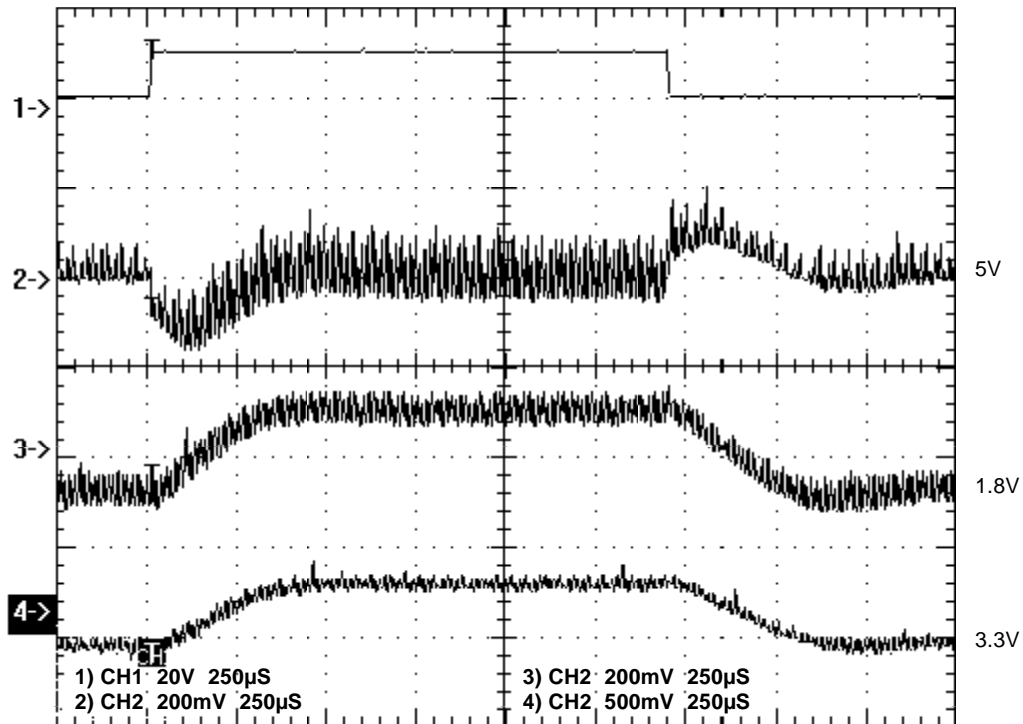

FIGURE 5. Transient response of Main (5V), AUX1 (1.8V) and AUX2 (3.3V)

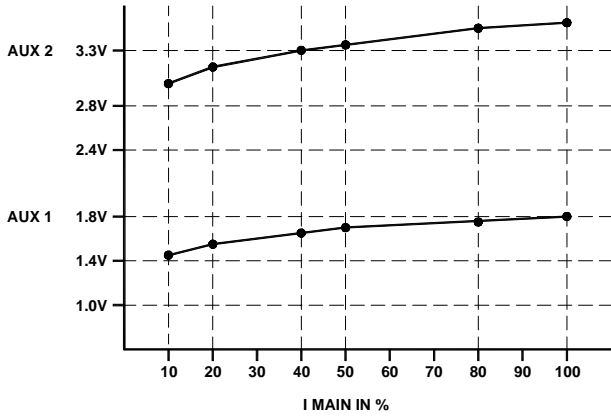

FIGURE 6. Auxiliary load regulation vs. Main load current (AUX1 and AUX2 are fully loaded)

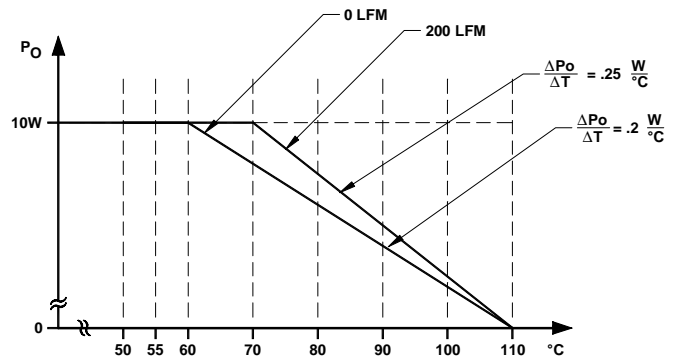

FIGURE 7. Derating of BD10017

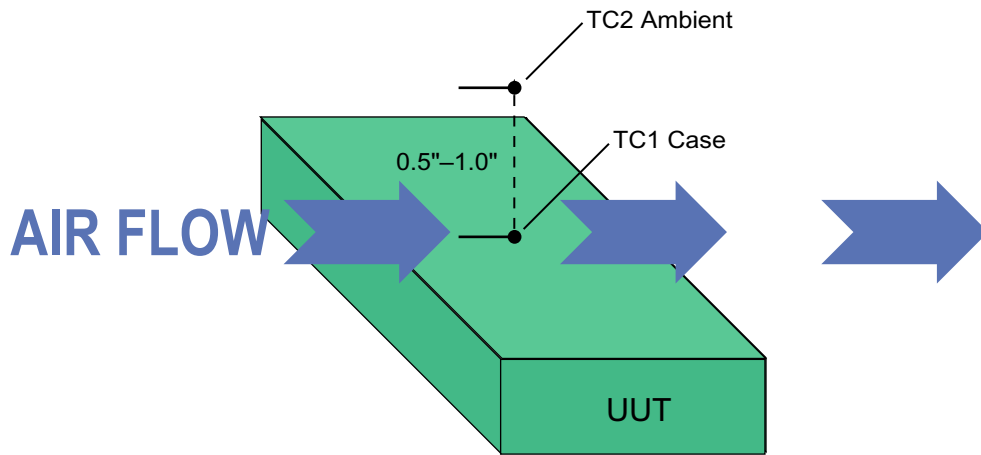

FIGURE 8. Setup for measuring case and ambient temperatures

The ambient temperature is measured with thermo-coupler #2, which is positioned 0.5"–1.0" above the center of the unit. When airflow is used, position the converter such that the 2" length of the converter is perpendicular to the airflow.