



BD10015B

10W HIGH-VOLTAGE
ADJUSTABLE OUTPUT DC/DC CONVERTER
Single $302.5V_{OUT}$

Key Features

- 81% efficiency
- Input-to-output isolation
- Short circuit and thermal protection
- Adjustable outputs
- 50 μ A off state current
- Wide input voltage range (36–75Vdc)



Functional Description

The BD10015B is a 10W High-Voltage Adjustable Output DC/DC Converter that accepts an input voltage from $36V_{IN}$ to $75V_{IN}$ and provides $302.5V_{OUT}$ between Pin 4 positive and Pin 7 negative. The output can be set to any output voltage between $250V_{OUT}$ to $305V_{OUT}$ by applying a voltage signal from 2.485Vdc to 3.0Vdc between Pin 8 positive and Pin 7 negative.

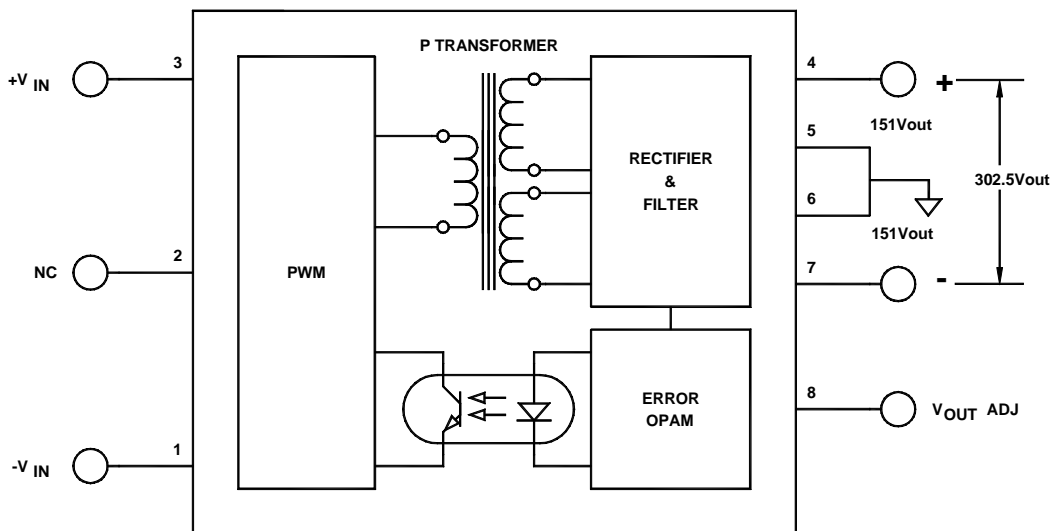

Typical Block Diagram

Electrical Specifications

ABSOLUTE MAXIMUM RATINGS

Unless otherwise specified, all parameters are given under typical +25°C with nominal input voltage and under full output load conditions.

PARAMETER	CONDITION / NOTE	MIN	TYP	MAX	UNIT
Input Voltage	175% of Nominal input line				
Output Short Circuit Duration	Continuous				
Internal Power Dissipation				3.4	W

INPUT SPECIFICATIONS

PARAMETER	CONDITION / NOTE	MIN	TYP	MAX	UNIT
Input Voltage Range (2:1)		36	48	75	Vdc
No Load Input Current			20		mA
Full Load Input Current			270		mA
Input Filter	C				
Reflected Ripple Current ¹			90		mA _{PP}
Reverse Voltage Protection	Parallel Diode		5		A
Turn On Delay	Including soft start	7	10	15	mS
Startup Input Voltage		11	16		Vdc

OUTPUT SPECIFICATIONS

PARAMETER	CONDITION / NOTE	MIN	TYP	MAX	UNIT
Voltage		250		306	Vdc
Current		0		33	mA
Output Voltage Accuracy			±1		%
Output Adjust Range			±10		%
Ripple & Noise (20MHz BW)	See Figure 1 for required external components	0.5	±1	±2	%
Line Regulation	See Figure 1 for required external components	0.5	±1	±2	%
Load Regulation	See Figure 1 for required external components	0.5	±1	±2	%
Temperature Coefficient @ FL				±0.02	%/°C
Short Circuit Protection	Continuous, Current Limit				
Short Circuit Restart	Automatic				
Transient Response (to within 1% of V _{OUT})	50% FL to 100% FL to 50% FL		500		µS

GENERAL SPECIFICATIONS

PARAMETER	CONDITION / NOTE	MIN	TYP	MAX	UNIT
Efficiency			81		%
Isolation Voltage (1 min.)		500	1000		Vdc
Isolation Resistance			10 ⁹		Ω
Isolation Capacitance			300		pF
Switching Frequency		108	125	130	kHz

ENVIRONMENTAL SPECIFICATIONS

PARAMETER	CONDITION / NOTE	MIN	TYP	MAX	UNIT
Operating Temperature Range (Ambient)	(For -55°C to +85°C, please contact factory)	-40		+70	°C
Storage Temperature Range		-60		+105	°C
Thermal Shutdown ²	Case Temperature	96	100	104	°C
Thermal Resistance			6		°C/W
Derating	None required				
Humidity	Up to 95% non-condensing				
Cooling	Free-air convection				
MTBF	per MIL-HNBK-217F (Ground benign, +25°C)		1.1×10 ⁶		hours

¹ Maximum Input Current: The maximum input current at any given input range measured at minimum input voltage is given as 1.6*^{NOMINAL}. Nominal input current is the typical value measured at the input of the converter under full load room temperature and nominal input voltage (48Vdc).

² Input voltage must be recycled after a thermal shutdown.

PHYSICAL CHARACTERISTICS

PARAMETER	CONDITION / NOTE	MIN	TYP	MAX	UNIT
Dimensions (LxWxH)	2.00x1.00x0.395 in. (50.80x25.40x10.03mm)				
Weight	1.04 oz. (30g)				
Case Material	Coated metal				
Shielding	Six-sided continuous				
Case Connection	48V _N				

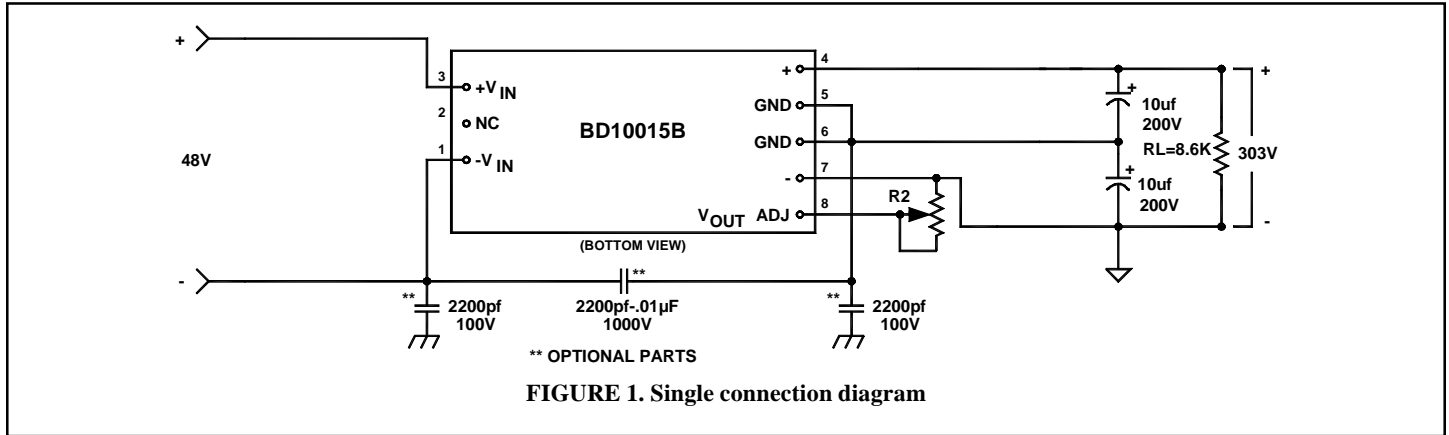

MECHANICAL SPECIFICATIONS

in inches [mm]

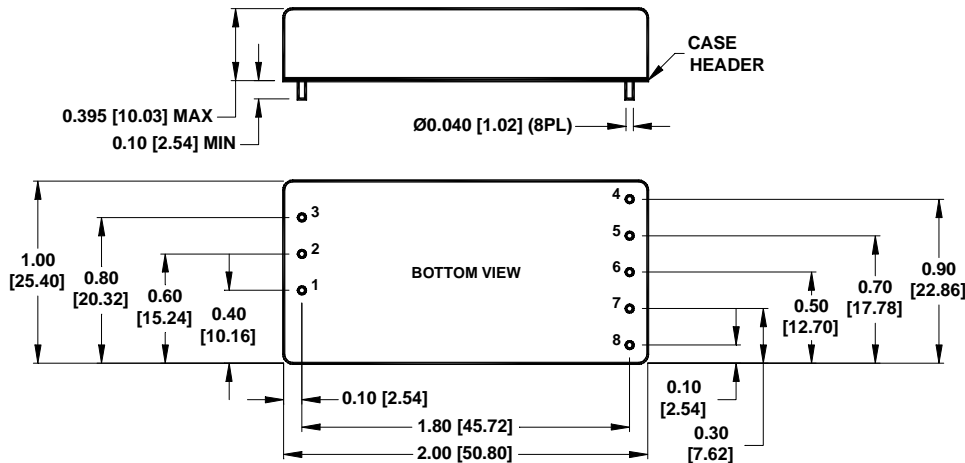

Pin	Function
1	-V _{IN}
2	No Connection
3	+V _{IN}
4	+V _{OUT}
5	GND (CONNECT PIN 5 TO 6)
6	GND (CONNECT PIN 5 TO 6)
7	-V _{OUT}
8	V _{OUT} ADJ

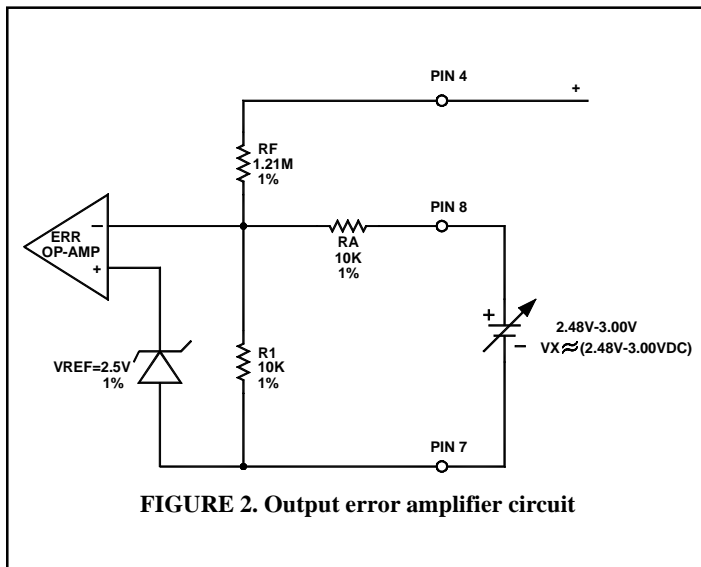

$$V_o = \left(\frac{R_F}{R_1} + 1 \right) V_{REF} \text{ (with Pin 8 open)}$$

$$V_o = \left(\frac{1.21 \times 10^6}{1 \times 10^4} + 1 \right) * 2.5 = 305 \text{ (with Pin 8 open)}$$

$$V_o = V_{REF} \left(\frac{R_F}{R_1} + \frac{R_F}{R_1} + 1 \right) - \frac{R_F}{R_1} V_x$$

$$R_{ADJUST} = R_A + R_R$$

$$R_1' = R_1 // (R_A + R_R) = \frac{R_F}{\frac{V_o}{V_{REF}} - 1}$$

For V_x = V_{REF}, V_o = 305Vdc

For V_x = 3.0, V_o = 249.5Vdc