



BD10014

10W HIGH-VOLTAGE DC/DC CONVERTER

Bipolar 100V_{OUT}

Key Features

- 81% efficiency
- Input-to-output isolation
- Soft start
- Hot pluggable
- Short circuit and thermal protection
- Adjustable outputs
- 50µA off state current
- Wide input voltage range (36–75Vdc)



Functional Description

The BD10014 is a 10W dual DC/DC converter designed for Mirco-Mirror Drivers. Input voltage range is 36V_{IN} to 75V_{IN}. Output can be adjusted from ±90V_{OUT} to ±110V_{OUT}.

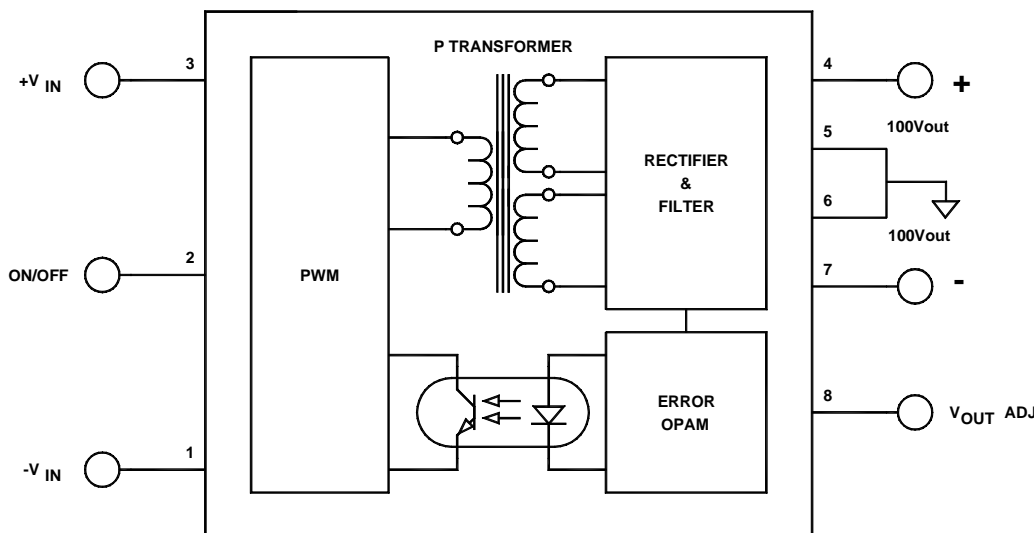

Typical Block Diagram

Electrical Specifications
ABSOLUTE MAXIMUM RATINGS

Unless otherwise specified, all parameters are given under typical +25°C with nominal input voltage and under full output load conditions.

PARAMETER	CONDITION / NOTE	MIN	TYP	MAX	UNIT
Input Voltage	175% of Nominal input line				
Output Short Circuit Duration	Continuous				
Internal Power Dissipation				3.4	W

INPUT SPECIFICATIONS

PARAMETER	CONDITION / NOTE	MIN	TYP	MAX	UNIT
Input Voltage Range (2:1)		36	48	75	Vdc
Input Filter ¹	RC				
Reflected Ripple Current ²			90		mA _{PP}
Reverse Voltage Protection	Parallel Diode		5		A
On/Off	Reference to -V _{IN}				
Voltage	Open		10		Vdc
Unit On	Open				
Unit Off	Short to -V _{IN}				
Off State Current	Pin 2 short to Pin 3		50	120	μA
Turn On Delay	Including soft start	7	10	15	mS
Startup Input Voltage		11	16		Vdc

OUTPUT SPECIFICATIONS

PARAMETER	CONDITION / NOTE	MIN	TYP	MAX	UNIT
Voltage			±100		Vdc
Current			50		mA
Output Voltage Accuracy			±1		%
Voltage Balance (Dual Outputs)	Equally loaded outputs		±1		%
Ripple & Noise (20MHz BW)			±1		%
Line Regulation			±1		%
Load Regulation			±1		%
Temperature Coefficient @ FL				±0.02	%/°C
Short Circuit Protection	Continuous, Current Limit				
Short Circuit Restart	Automatic				
Transient Response (to within 1% of V _{OUT})	50% FL to 100% FL to 50% FL		100		μS

GENERAL SPECIFICATIONS

PARAMETER	CONDITION / NOTE	MIN	TYP	MAX	UNIT
Efficiency			81		%
Isolation Voltage (1 min.)		500	1000		Vdc
Isolation Resistance			10 ⁹		Ω
Isolation Capacitance			300		pF
Switching Frequency		108	125	130	kHz

ENVIRONMENTAL SPECIFICATIONS

PARAMETER	CONDITION / NOTE	MIN	TYP	MAX	UNIT
Operating Temperature Range (Ambient)	(For -55°C to +85°C, please contact factory)	-40		+75	°C
Storage Temperature Range		-60		+105	°C
Derating	None required				
Humidity	Up to 95% non-condensing				
Cooling	Free-air convection				
MTBF	per MIL-HNBK-217F (Ground benign, +25°C)		1.1x10 ⁶		hours

PHYSICAL CHARACTERISTICS

PARAMETER	CONDITION / NOTE	MIN	TYP	MAX	UNIT
Dimensions (LxWxH)	2.00x1.00x0.395 in. (50.80x25.40x10.03mm)				
Weight	1.04 oz. (30g)				
Case Material	Coated metal				
Shielding	Six-sided continuous				
Case Connection	48V _N				

¹ The RC input filter utilizes the R_{ON} of the series MOSFET transistor which is part of the hot pluggable circuit. The benefits of this RC filters are the reduction of inrush current by approximately 27dB and reflected ripple attenuation by 8dB. The penalty for the hot pluggability and the RC filter is 1% to 2% reduction of the converter's efficiency. See Figures 2 and 3.

² The maximum input current at any given input range measured at minimum input voltage is given as 1.6*I_{NOMINAL}. Nominal input current is the typical value measured at the input of the converter under full-load room temperature and nominal input voltage (48Vdc).

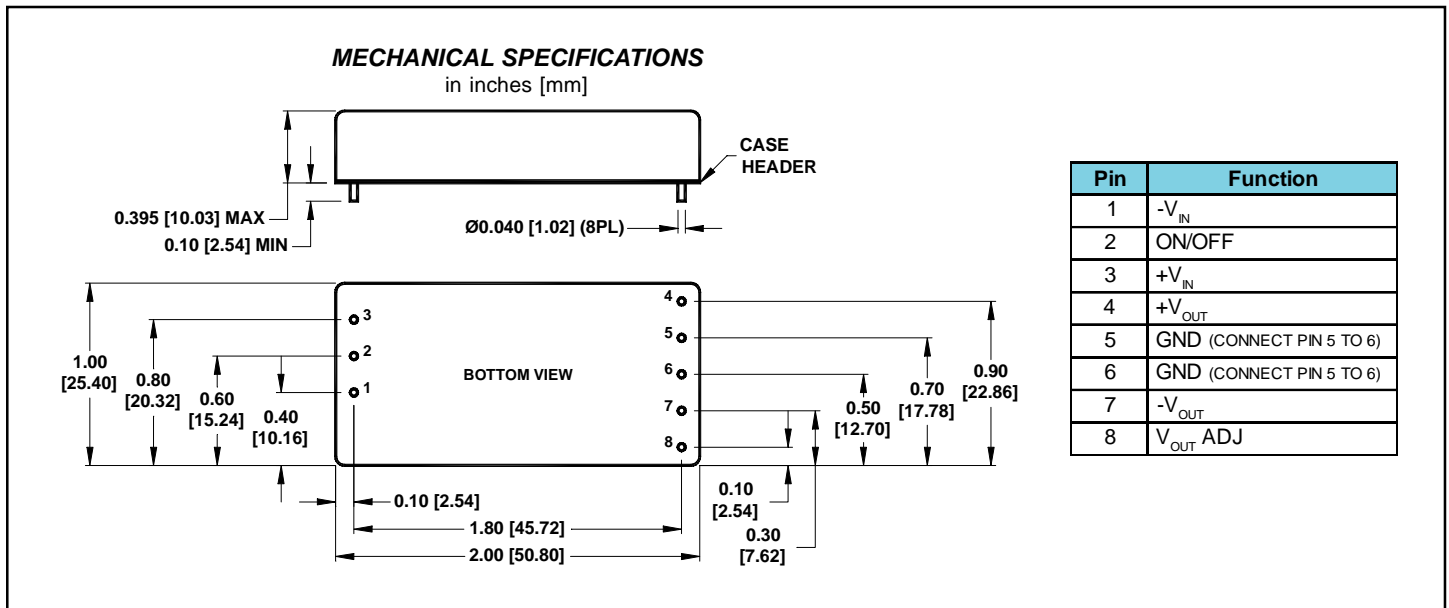
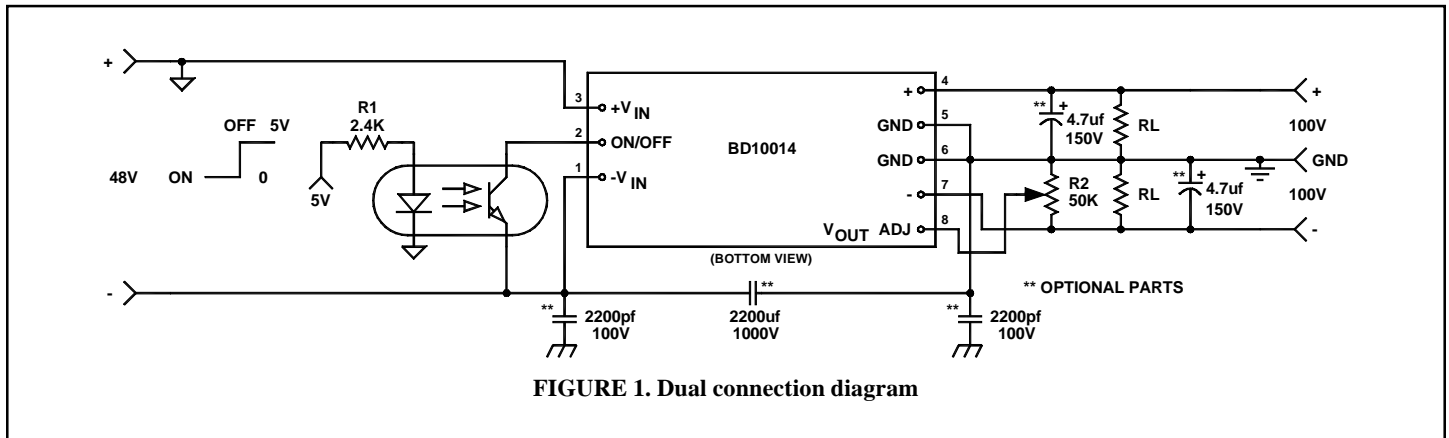

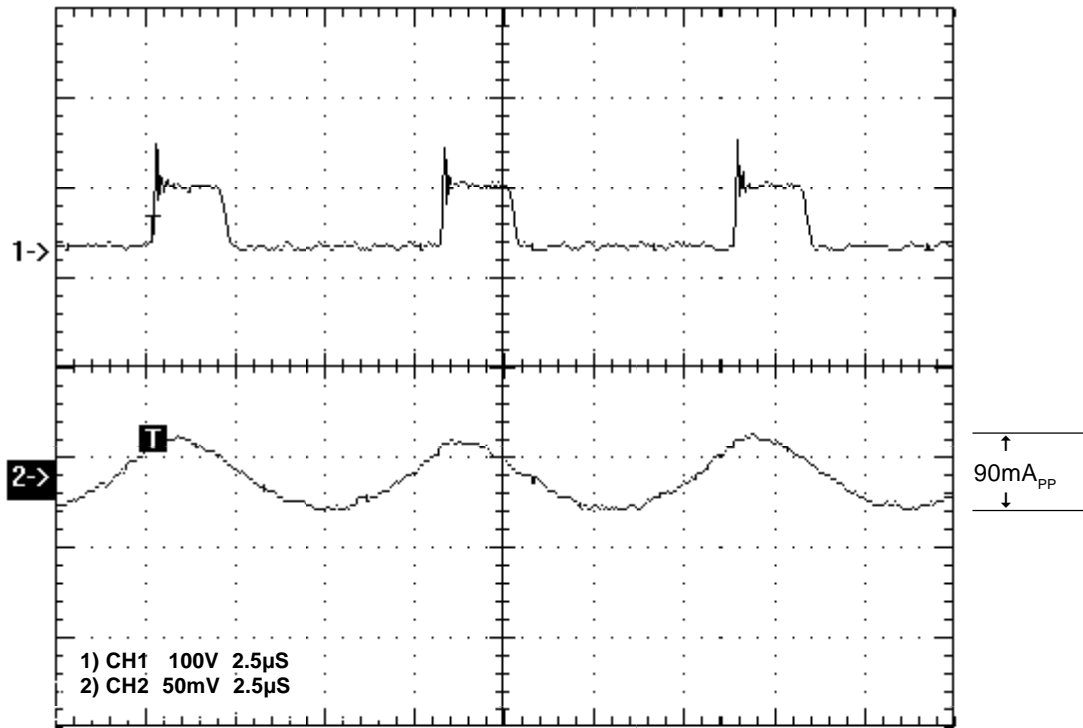

FIGURE 2A. (CH2) 10W reflected ripple *with* hot pluggable circuit, V_{IN} 36V

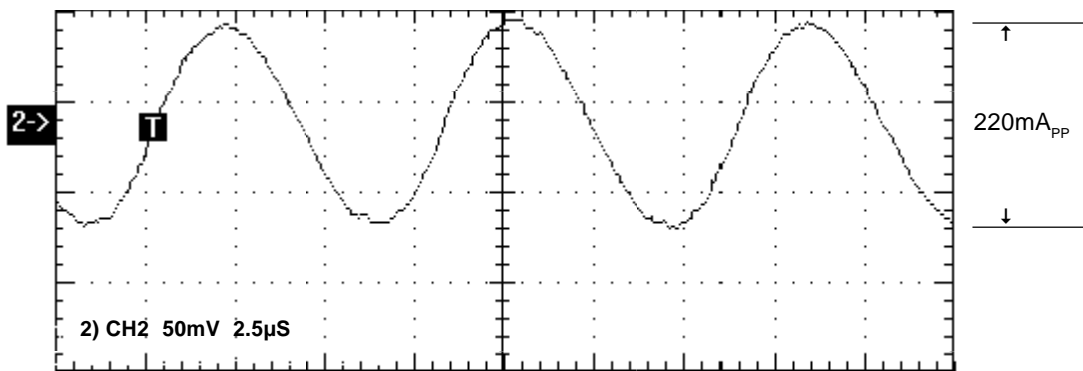

FIGURE 2B. (CH2) 10W reflected ripple *without* hot pluggable circuit

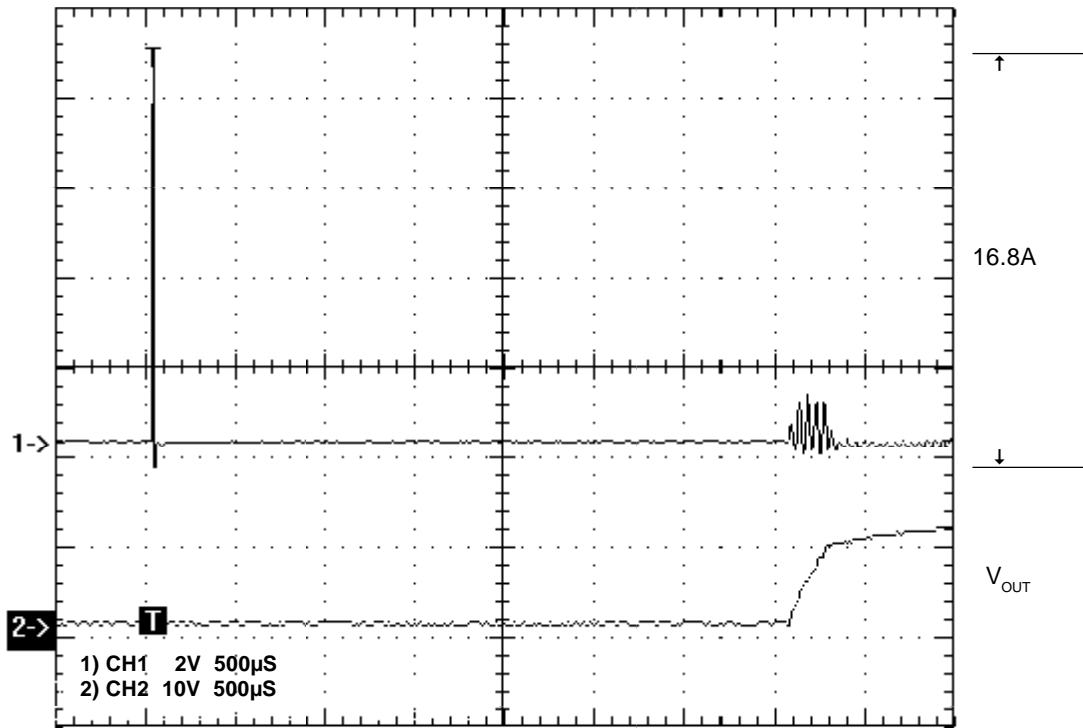

FIGURE 3A. (CH1) Inrush current *without* hot pluggable circuit ON
 V_{IN} 48V, Current spike duration 5 μ S

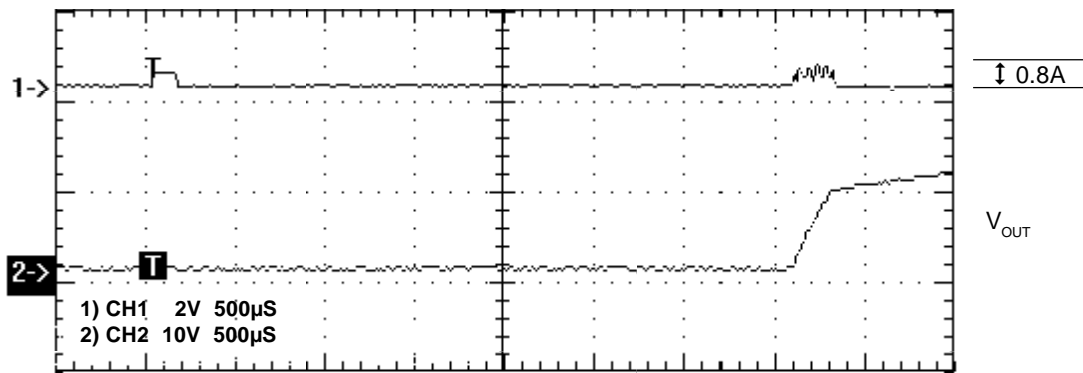

FIGURE 3B. (CH1) Inrush current *with* hot pluggable circuit ON