



Q25002

30W DC/DC CONVERTER

9-36Vin, +/-15Vout@+/-1000mA

Key Features

- Efficiency 83%
- Low output noise
- Six-sided shielding
- Input-to-output isolation
- Soft start
- External synchronization
- Short circuit protection
- Thermal protection
- Industry standard pinout



Beta Dyne is protected under various patents, including but not limited to U.S. Patent numbers: 5,777,519; 6,188,276; 6,262,901; 6,452,818; 6,473,3171.

Functional Description

The Q25001 is a 4:1 input range DC/DC converter that accepts 9-36Vin and provide +/-15Vout @ +/-1000mA. The converter is designed to synchronize to an external clock of 400kHz.

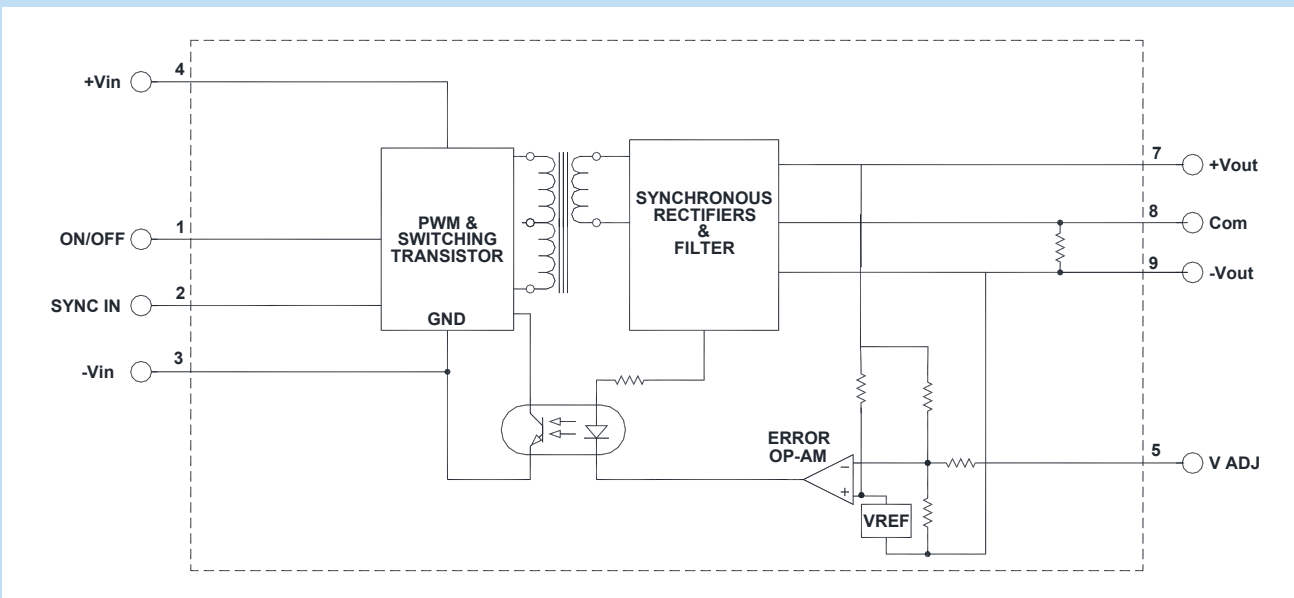

Typical Block Diagram

Electrical Specifications

INPUT SPECIFICATIONS

PARAMETER	CONDITION / NOTE	MIN	TYP	MAX	UNIT
Input Voltage Range		9	24	36	Vdc
Input Startup Voltage		8		9	Vdc
Input Overvoltage Shutdown $24 V_{IN}$		37			Vdc
Input Filter	C				
No Load Input Current			47		mA
Full Load Input Current			1495		mA
Input Surge Current (20 μ S Spike)				10	A
Short Circuit Current Limit	120% Of I_{IN} @ Full Load				
Off State Current			2.5		mA
Remote ON/OFF Control					
Supply ON	Pin 3 Open (Open circuit voltage: 10V Max.)				
Supply OFF		0		0.6	Vdc
Logic Input Reference	-Vin				
Logic Compatibility	TTL Open Collector or CMOS Open Drain				

OUTPUT SPECIFICATIONS

PARAMETER	CONDITION / NOTE	MIN	TYP	MAX	UNIT
Voltage			+/-15		Vdc
Output Voltage Accuracy	with balanced loads		1	1.5	%
Output Current			+/-1000		mA
Output Voltage Adjustment			± 5	± 10	%
Ripple & Noise	For further reduction see Figure 1		40		mV
Line Regulation	Minimum V_{IN} to maximum V_{IN}		± 1		%
Load Regulation	10% to FL, with balanced loads		± 1		%
Temperature Coefficient @ FL			.01	.02	%/ $^{\circ}$ C
Transient Response Time	50% FL to FL to 50% FL, within 1% of Vo, See Figure 6	100			μ S
Short Circuit Protection	By Hiccup Technique				
Output Overvoltage Protection	None				

GENERAL SPECIFICATIONS

PARAMETER	CONDITION / NOTE	MIN	TYP	MAX	UNIT
Efficiency (at full power)			83		%
Isolation Voltage (1 min.), Input to Output			1500		Vdc
Isolation Resistance			10^9		Ω
Isolation Capacitance			300		pF
Switching Frequency (FC)			375		kHz
External Sync Frequency (Fe)	See figure 8 & 9		400		kHz

PHYSICAL CHARACTERISTICS

PARAMETER	CONDITION / NOTE	MIN	TYP	MAX	UNIT
Dimensions (LxWxH)	2.00x1.00x0.450 in. (50.80x25.40x11.43mm)				
Weight	1.3 oz. (37g)				

ENVIRONMENTAL SPECIFICATIONS

PARAMETER	CONDITION / NOTE	MIN	TYP	MAX	UNIT
Operating Temperature Range (Ambient)	Industrial, See Note 2	-40		+71	$^{\circ}$ C
Storage Temperature Range		-55		+125	$^{\circ}$ C
Maximum Operating Case Temperature				110	
Thermal Resistance	See derating curve, figure 7	4.3		4.7	$^{\circ}$ C/W
MTBF	per MIL-HNBK-217F(Ground benign, +25 $^{\circ}$ C)		1.1×10^6		hours
Shielding Connection	-Vin for 24Vin				

¹ When converter enters thermal protection on mode, its duty cycle is reduced momentarily and will resume after its internal temperature (pwm) drops down a few degrees (°C).The converter's output behaves similar to hiccup short circuit mode.

² Contact factory for -55° to +85°C operating temperature range.

³ The maximum input current at any given input range measured at minimum input voltage is given as $1.6 \cdot I_{NOMINAL}$. Nominal input current is the typical value measured at the input of the converter under full-load room temperature and nominal input voltage (24 and 48V_{IN}).

⁴ Adequate insulation is to be provided to the converters at the end usage as per applicable requirements.

⁵ Temperature rise on the case of the converters is to be considered during the end usage as per applicable requirements. To maintain a less than 110°C case temperature, with a I_{out}=+/-1A, you need 200LFM.

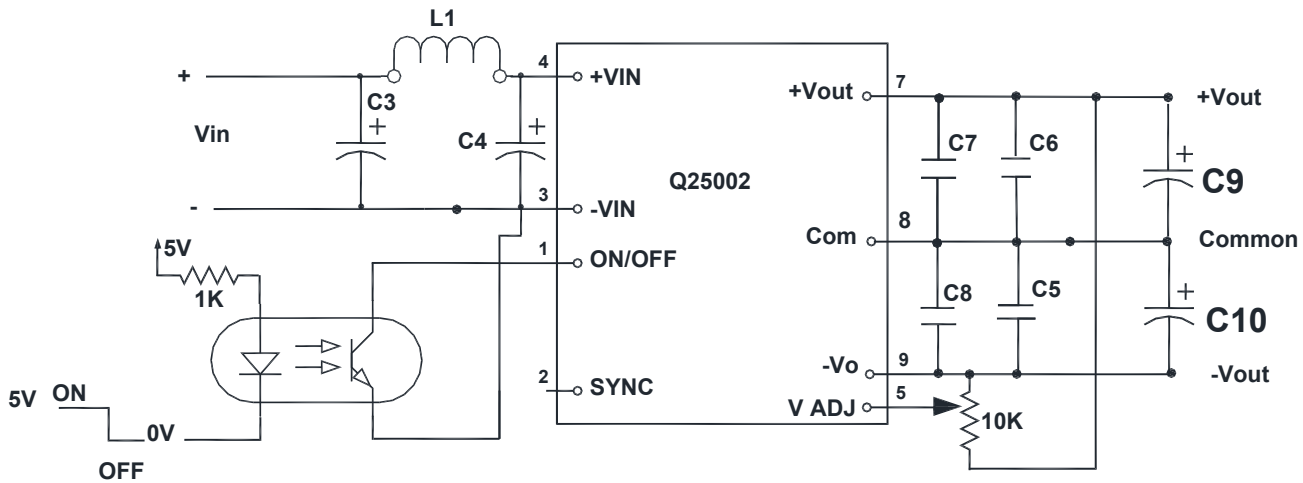

FIGURE 1. Typical connection diagram for Q25002

Part list for Figure 1:

L1= 2.2μH

C3= 50μF@100V Electrolytic

C4=50μF@100V Electrolytic

C7,C8= 10μF Ceramic Capacitors

C5,C6=47μF@25V tantalum

C9,C10= 180μF@16V Low ESR Capacitors from Nippon Chemi-Con, optional

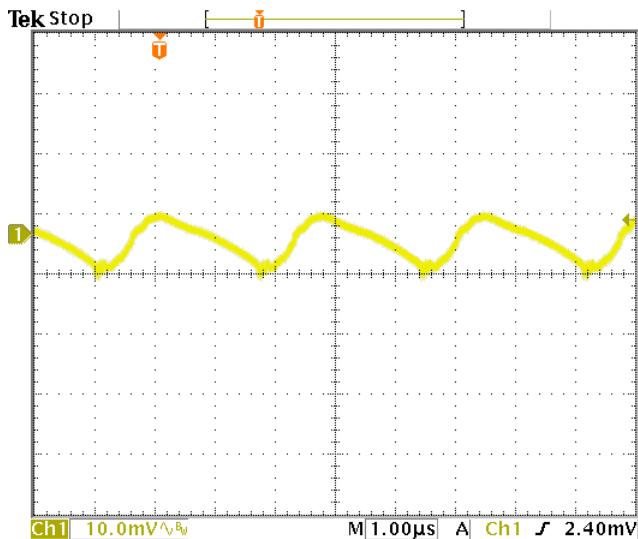

FIGURE 2: Output ripple of Q25002 on +Vout as shown in Figure 1, with 47μF@25V tantalum Low ESR.

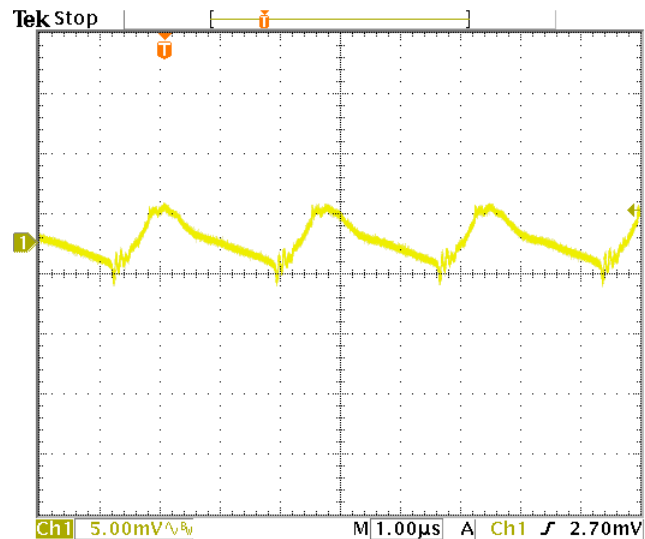

FIGURE 3: Output ripple of Q25002 on +Vout with another external cap of Nippon Chemi-Con 180μF@16V on the +Vout. The part number is 16PS180MH11.

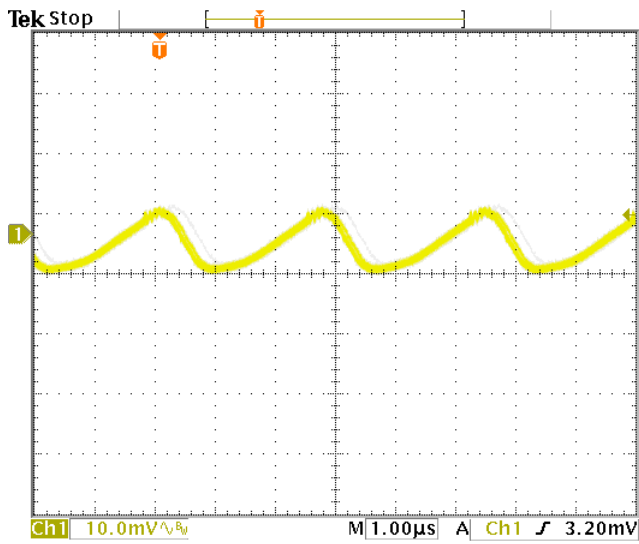

FIGURE 4: Output ripple of Q25002 on -Vout as shown in Figure 1.

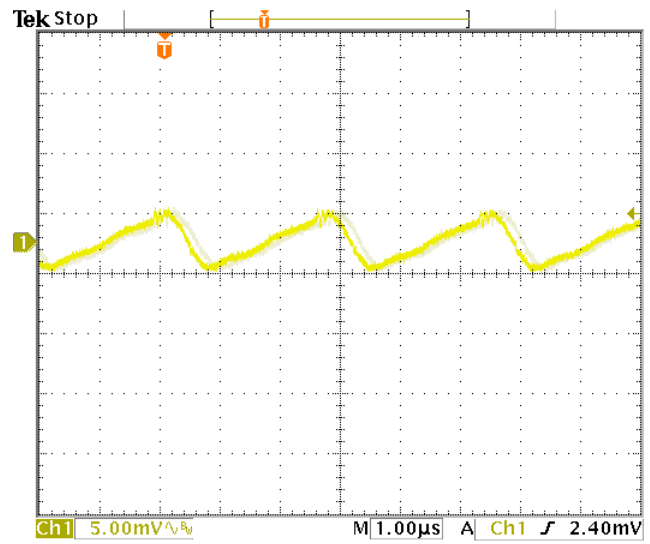

FIGURE 5: Output ripple of Q25002 on -Vout with another external cap of Nippon Chemi-Con 180µF@16V on the +Vout. The part number is 16PS180MH11.

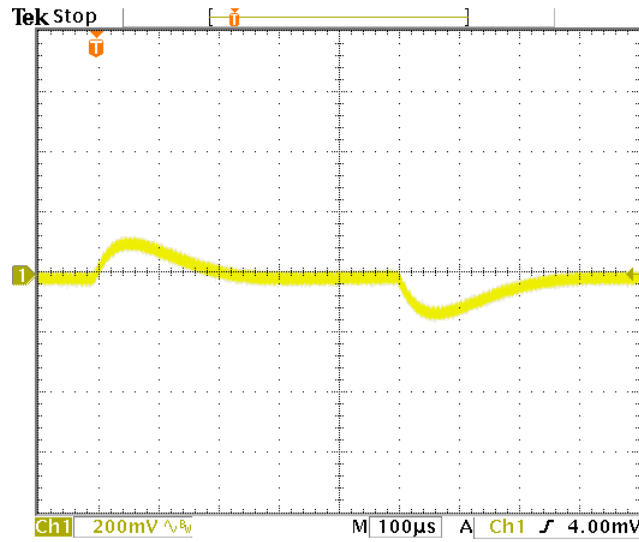

FIGURE 6. Transient Response at Vin=24, Iout changing from Full load to Half load on a Q25002.

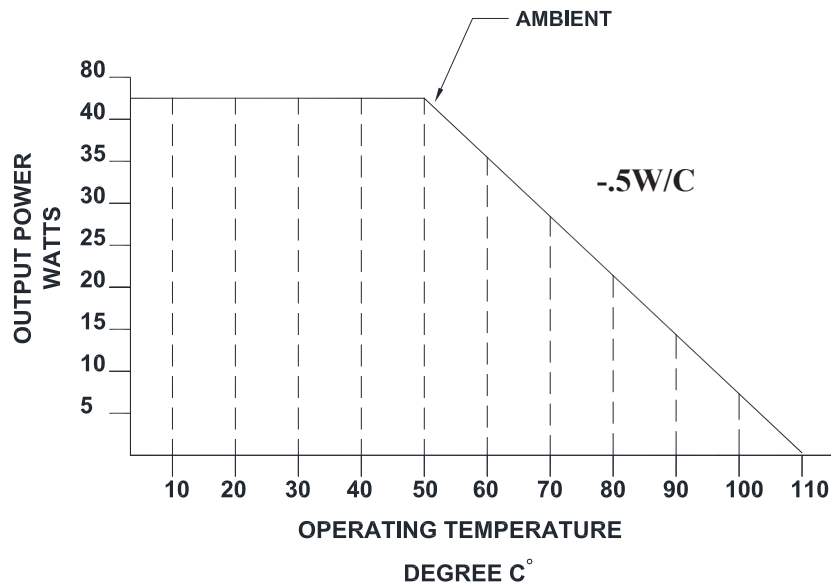

FIGURE 6. Derating Curve of Q25002

EXTERNAL SYNCHRONIZATION

The SYNC pin can be used to synchronize the internal oscillator to external clock. An open drain output is the recommended interface between the external clock to the Q25 SYNC pin as shown in figure 8. The clock pulse width must be greater than 15ns. The external clock frequency must be greater than the frequency of the Q25.

Multiple Q25 converters can be synchronized together simply by connecting the converters SYNC pins together as shown in figure 9. Care should be taken to ensure the ground potential differences between the converters are minimized. In this configuration all the converters will be synchronized to the highest frequency device. The SYNC pin is a CMOS buffer with pull-up current limited to 200micro amps. If the external device forces the SYNC pin low before the internal oscillator ramp completes its charging cycle, the ramp will reset and another cycle begins. If the SYNC pins of multiple Q25 converters are connected together, the first SYNC pin that pulls low will reset the oscillator ramp of all the other converters. All converters will operate in phase when synchronized using the SYNC feature. Up to five devices can be synchronized using this method.

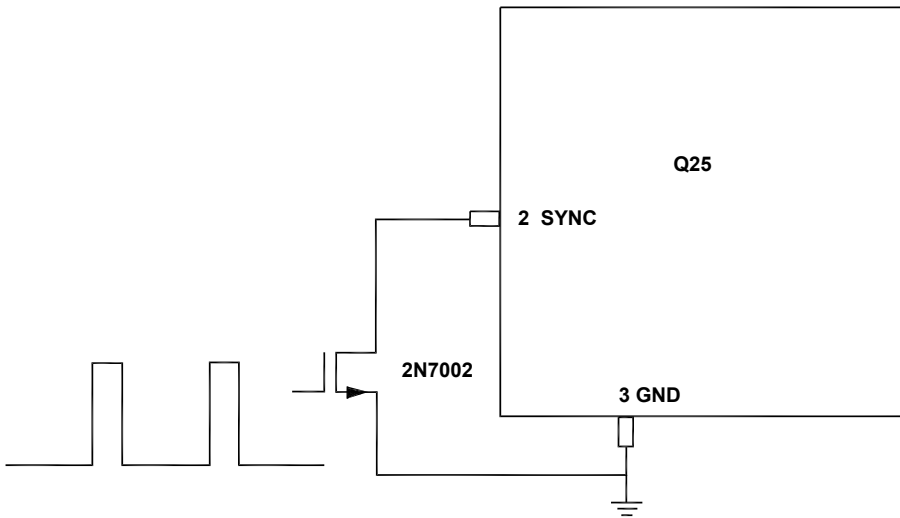

FIGURE 8. SYNC from external clock

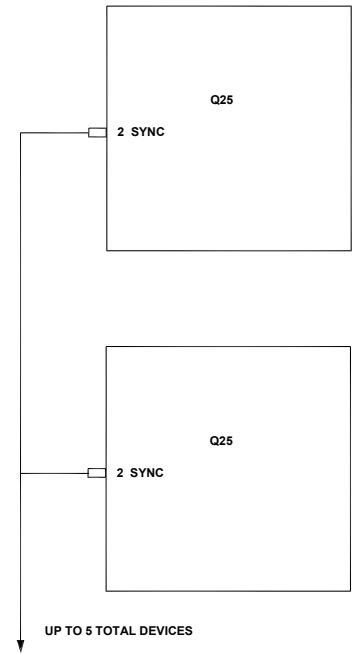
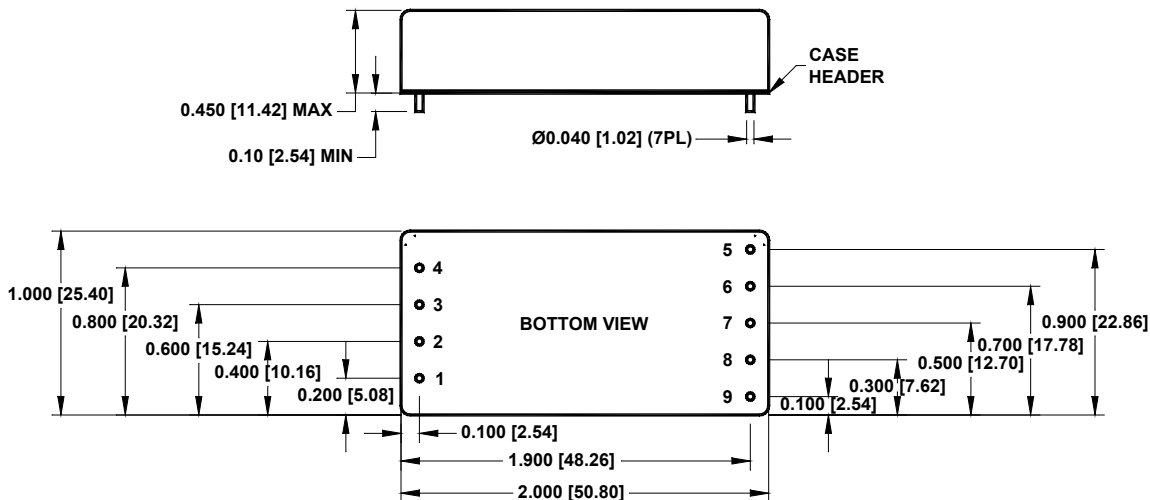

FIGURE 9. SYNC of multiple devices

DIMENSION ARE IN INCH(mm)
TOLERANCE: .XX ±.02(.508)
.XXX ±.01(.254)

MECHANICAL SPECIFICATIONS



Pin	Function
DUAL	
INPUT	
1	ON/OFF
2	SYNC IN
3	-V _{IN}
4	+V _{IN}
OUTPUT	
5	V _{ADJ}
6	No Pin
7	+V _{OUT}
8	Common
9	-V _{OUT}