



LN10020X

LOW-NOISE 10W DC/DC CONVERTER

36-72V_{in}, +12.5V@ up to 1A, -12.5V@ up to 80mA

Key Features

- Wide input voltage range (2:1)
- Less than 5mV output noise
- Efficiency up to 86%
- Six-sided shielding
- Soft start
- Short circuit protection
- Adjustable output
- 1mA off state current
- 250mV dropout linear regulators
- Dual output tracking linear regulator
- 5μS transient response
- Industry pinouts



NOTE: Label on the side.

Beta Dyne is protected under various patents, including but not limited to U.S. Patent numbers: 5,777,519; 6,188,276; 6,262,901; 6,452,818; 6,473,3171.

Applications

- High-Resolution Data Converters
- Instrumentation
- Test & Measurement
- Telecom

Functional Description

The LN10020x is a dual output, isolated DC/DC converter that accepts 36V_{IN} to 72V_{IN} and provides +12.5 up to 1A, -12.5 up to 100mA. The converter's design is based on Beta Dyne's patents and offers low noise and an extended operating temperature range from -55°C to 82°C. The converter is designed to synchronize to an external frequency: $f_{\text{SYNC}} \geq 395 \text{ kHz}$.

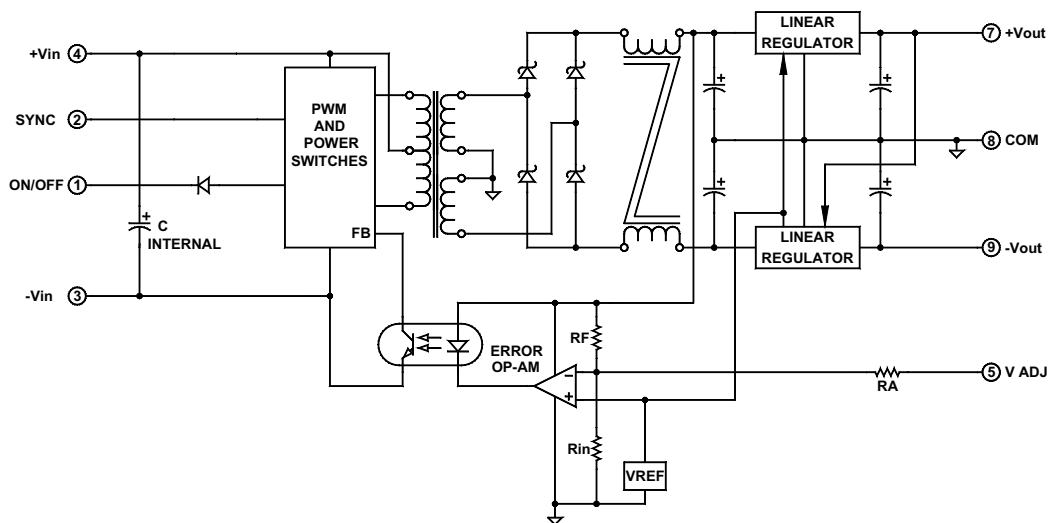

Typical Block Diagram of LN10W Dual Output Converter

Electrical Specifications

INPUT SPECIFICATIONS

Unless otherwise specified, all parameters are given under typical +25°C with nominal input voltage and under full output load conditions.

PARAMETER	CONDITION / NOTE	MIN	TYP	MAX	UNIT
Input Voltage Range		36	48	72	V
Full Load Input Current	+12.5V@1A, -12.5V@-.080A		350		mA
Input Filter	C				
Reverse Polarity Input Current	External series-blocking diode			12	A
Input Surge Current (20µs Spike)				10	A
Short Circuit Current Limit			150		% I _{IN}
Undervoltage Shutdown		4.5			Vdc
Off State Current, 12, 24, 48V			750		µA
Remote ON/OFF Control					
Converter ON	Open (Open circuit voltage at Pin 1: 10V Max.)				
Converter OFF		-0.6	0	0.2	Vdc
Logic Input Reference	-Input				
Logic Compatibility	TTL Open Collector or CMOS Open Drain				

OUTPUT SPECIFICATIONS

PARAMETER	CONDITION / NOTE	MIN	TYP	MAX	UNIT
Voltage and Current Ratings	See Model Selection Guide		±12.5		
Output Voltage Accuracy, Single and Dual			±1	±2.0	%
Output Voltage Adjustment			3	±5	%
Voltage Balance, Dual ¹	With Balanced Loads		±0.2	±0.5	%
Minimum Load ¹		10			% of FL
Ripple & Noise	See Figure 4		5	15	mV _{PP}
Line Regulation, Single and Dual	Minimum V _{IN} to maximum V _{IN}		0.05	0.1	%
Load Regulation, Single	NL to FL		0.05	0.1	%
Load Regulation, Dual ²			±1		%
Temperature Coefficient @ FL			0.02		%/°C of V _{OUT}
Transient Response Time (to within 0.5% of V _{OUT})	50% FL to FL to 50% FL, See Figure 1		5		µS
Short Circuit Protection	All outputs, by input current limiting				

GENERAL SPECIFICATIONS

PARAMETER	CONDITION / NOTE	MIN	TYP	MAX	UNIT
Efficiency	See Model Selection Guide		80		
Isolation Voltage (1 min.)			1500		Vdc
Isolation Resistance			10 ⁹		Ω
Isolation Capacitance			80		pF
Switching Frequency			370		kHz

ENVIRONMENTAL SPECIFICATIONS

PARAMETER	CONDITION / NOTE	MIN	TYP	MAX	UNIT
Operating Temperature, Industrial (Ambient) ¹	See Figure 2	-40		+75	°C
Operating Temperature, Extended (X)	See Ordering Guide (Please contact factory)	-55		+85	°C
Storage Temperature Range		-55		+125	°C
Thermal Resistance			3.5	4	°C/W _{DISS}
Maximum Operating Case Temperature				105	°C
Derating	See Figure 2				
Humidity	Up to 95% non-condensing				
Cooling	Free-air convection				
EMI/RFI	Six-sided continuous shielded metal case				
MTBF	per MIL-HNBK-217F (Ground benign, +25°C)		1×10 ⁶		hours

PHYSICAL CHARACTERISTICS

PARAMETER	CONDITION / NOTE	MIN	TYP	MAX	UNIT
Dimensions (L×W×H)	2.00×1.00×0.395 in. (50.80×25.40×10.03mm)				
Weight	1.04 oz. (30g)				
Case Material	Coated metal				
Shielding Connection, 5, 12, 24V _{IN}	-Input (Pin 3)				
Shielding Connection, 48V _{IN}	+Input (Pin 4)				

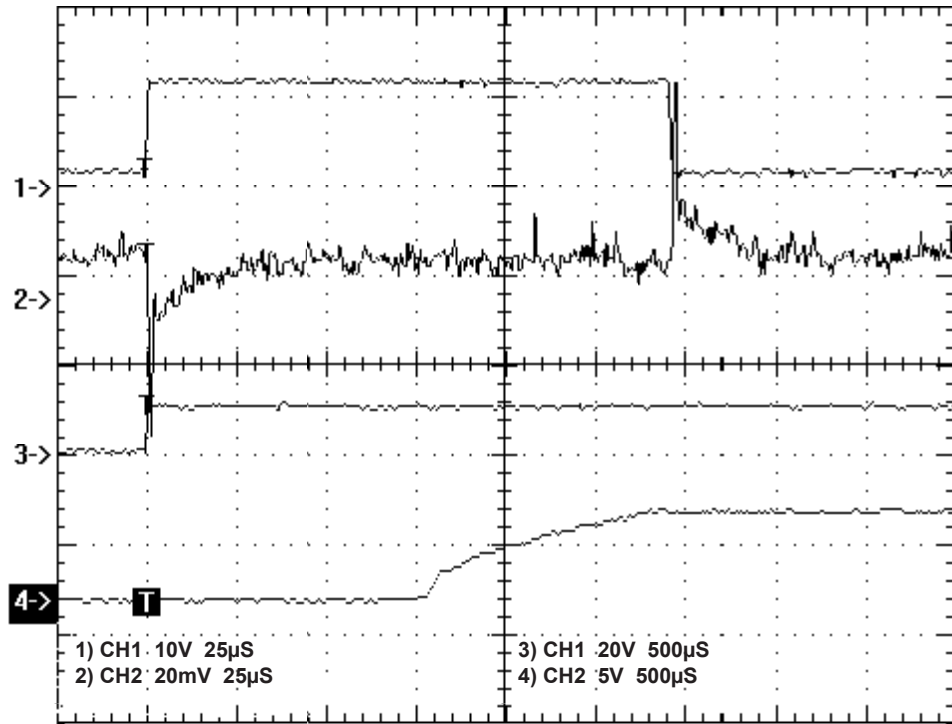

FIGURE 1. Transient response and turn on delay with soft start

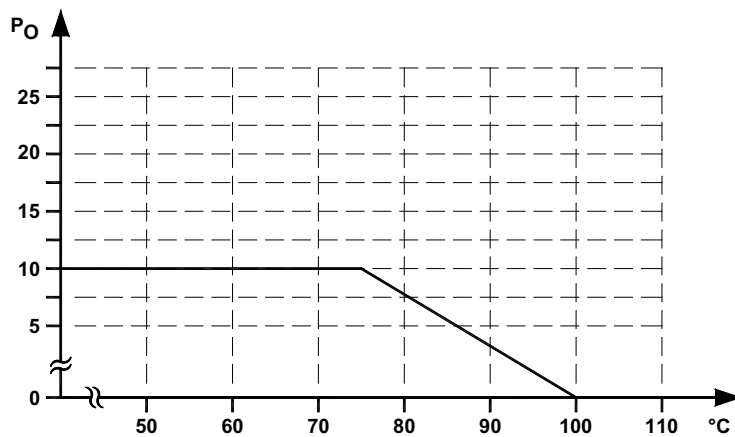

FIGURE 2. Typical derating curve of Low-Noise 10W series

OUTPUT VOLTAGE ADJUSTMENT

For both single and dual models, the output reference voltage is referenced to the output ground: Pin 6 for singles and Pin 8 for duals. To trim the output voltage high, connect a 1% resistor (0kΩ–200kΩ range) between -V_{OUT} (Pin 6) and V_{OUT} Adjust (Pin 9) for the singles, and COM (Pin 8) and V_{OUT} Adjust (Pin 5) for the duals. To trim the output voltage low, connect a 1% resistor (50kΩ–500kΩ range) between +V_{OUT} (Pin 5) and V_{OUT} Adjust (Pin 9) for the singles,

and +V_{OUT} (Pin 7) and V_{OUT} Adjust (Pin 5) for the duals.

With the wiper connected to the V_{OUT} Adjust pin, a variable resistor (potentiometer) can also be used for V_{OUT} adjustment by connecting each end to +V_{OUT} and -V_{OUT} for the singles, and +V_{OUT} and COM for the duals. A potentiometer between 50kΩ–100kΩ can be used. Avoid using a low resistance potentiometer or a high temperature coefficient such as wound wire.

**MECHANICAL SPECIFICATIONS
STANDARD CASE**

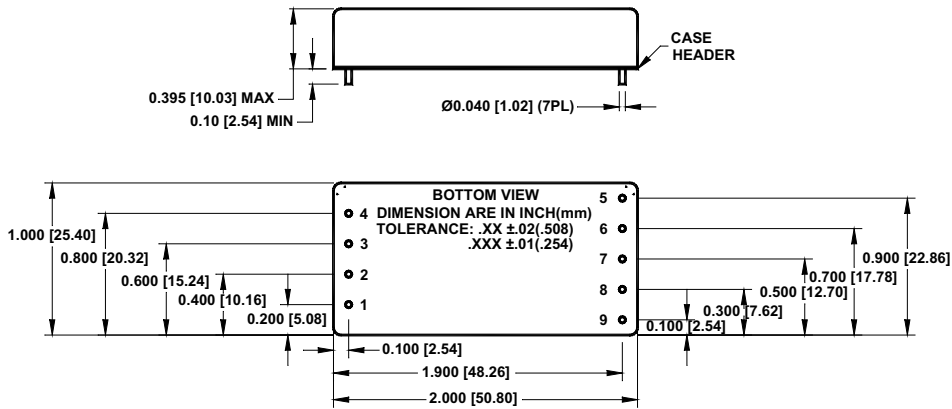

STANDARD CASE

Pin	Function	
	SINGLE	DUAL
1	ON/OFF	ON/OFF
2	SYNC	SYNC
3	-V _{IN}	-V _{IN}
4	+V _{IN}	+V _{IN}
5	+V _{OUT}	V _{OUT} ADJ
6	GND	No Pin
7	No Pin	+V _{OUT}
8	No Pin	COM
9	V _{OUT} ADJ	-V _{OUT}

EXTERNAL SYNCHRONIZATION

This series of converters can be synchronized to an external system clock of 395kHz -2% to 10%. The external clock is AC-coupled to the input SYNC terminal (Pin 2) through a coupling capacitor

from 220pF to 1000pF. The required amplitude is 3.3V to 5V and its duty cycle is 50% ±20%. Please refer to *Application Note DC-005: Synchronization* for more information.