



BDH10019
1W SINGLE DC/DC CONVERTER
 30-300 V_{IN} (V_{IN} P_{PEAK} 400V) 3.3V_{OUT}@0.2A

Key Features

- Input-to-output isolation
- Soft start
- Short circuit and thermal protection
- EMI six-sided shielding
- Frequency Jitter Modulation



Functional Description

The BDH10019 is a 1W single DC/DC converter in a 2×1×0.395-inch package that provides 3.3V_{OUT}@0.2A with an operating temperature range from -40°C to +85°C. Switching frequency jitter modulation reduces EMI while its six-sided shielding eliminates RFI.

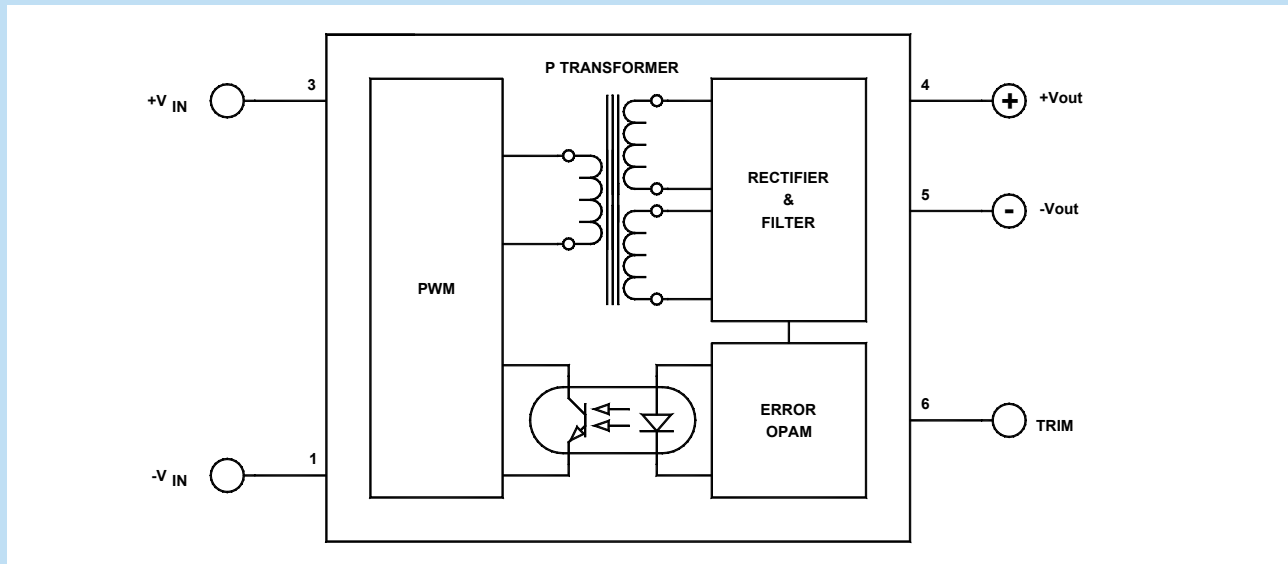

Typical Block Diagram

Electrical Specifications

INPUT SPECIFICATIONS

Unless otherwise specified, all parameters are given under typical +25°C with nominal input voltage and under full output load conditions.

PARAMETER	CONDITION / NOTE	MIN	TYP	MAX	UNIT
Input Voltage Range		30		300	Vdc
Input Voltage Slew Rate				10	V/μS
No Load Input Current	@270Vin		4.5		mA
Full Load Input Current	@270Vin		6.5		mA
Input Filter	NONE				
Reflected Ripple Current	Measured with 10μF input capacitor		100		mA _{pp}
Reverse Voltage Protection	Parallel Diode		5		A
On/Off	Reference to -V _{IN}				
Converter ON	Open		10		Vdc
Turn On Delay	Including soft start, See Figure 2		25	35	mS
Startup Input Voltage		25			Vdc

OUTPUT SPECIFICATIONS

PARAMETER	CONDITION / NOTE	MIN	TYP	MAX	UNIT
Output Voltage			3.3		Vdc
Output Voltage Accuracy			1	2	%
Output Adjust Range			10		% of V _{out}
Output Current			0.2		A
Ripple & Noise (20MHz BW)			0.5	1	% of V _{OUTPP}
Line Regulation	Outputs fully loaded		1		%
Load Regulation	10% FL to FL		1		%
Temperature Coefficient @ FL			±0.02		%/°C
Short Circuit Protection	Continuous, Current Limit				
Short Circuit Restart	Automatic				
Transient Response (to within 1% of Vout)	50% FL to 100% FL to 50% FL ,See Figure 3		500		μS

GENERAL SPECIFICATIONS

PARAMETER	CONDITION / NOTE	MIN	TYP	MAX	UNIT
Efficiency			52		%
Isolation Voltage (1 min.)		500	1000		Vdc
Isolation Resistance			10 ⁹		Ω
Isolation Capacitance			300		pF
Switching Frequency		115	130	140	kHz
Frequency Jitter			±4		kHz
Frequency Jitter Modulation			250		Hz

ENVIRONMENTAL SPECIFICATIONS

PARAMETER	CONDITION / NOTE	MIN	TYP	MAX	UNIT
Operating Temperature Range (Ambient)		-40		+85	°C
Storage Temperature Range		-60		+125	°C
Derating	None is required				
Thermal Protection, Turn Off ¹	Junction Temperature		145		°C
Thermal Hysteresis			30		°C
Humidity	Up to 95% non-condensing				
Cooling	Free-air convection				
MTBF	per MIL-HNBK-217F (Ground benign, +25°)		2.076x10 ⁶		hours

¹ Input power may have to be recycled after thermal turn off.

PHYSICAL CHARACTERISTICS

PARAMETER	CONDITION / NOTE	MIN	TYP	MAX	UNIT
Dimensions (LxWxH)	2.00x1.00x0.395 in (50.80x25.40x10.03mm)				
Weight	1.04 oz (30g)				
Case Material	Coated metal				
Shielding	Six-sided continuous				
Case Connection	-V _{IN} (Pin 1)				

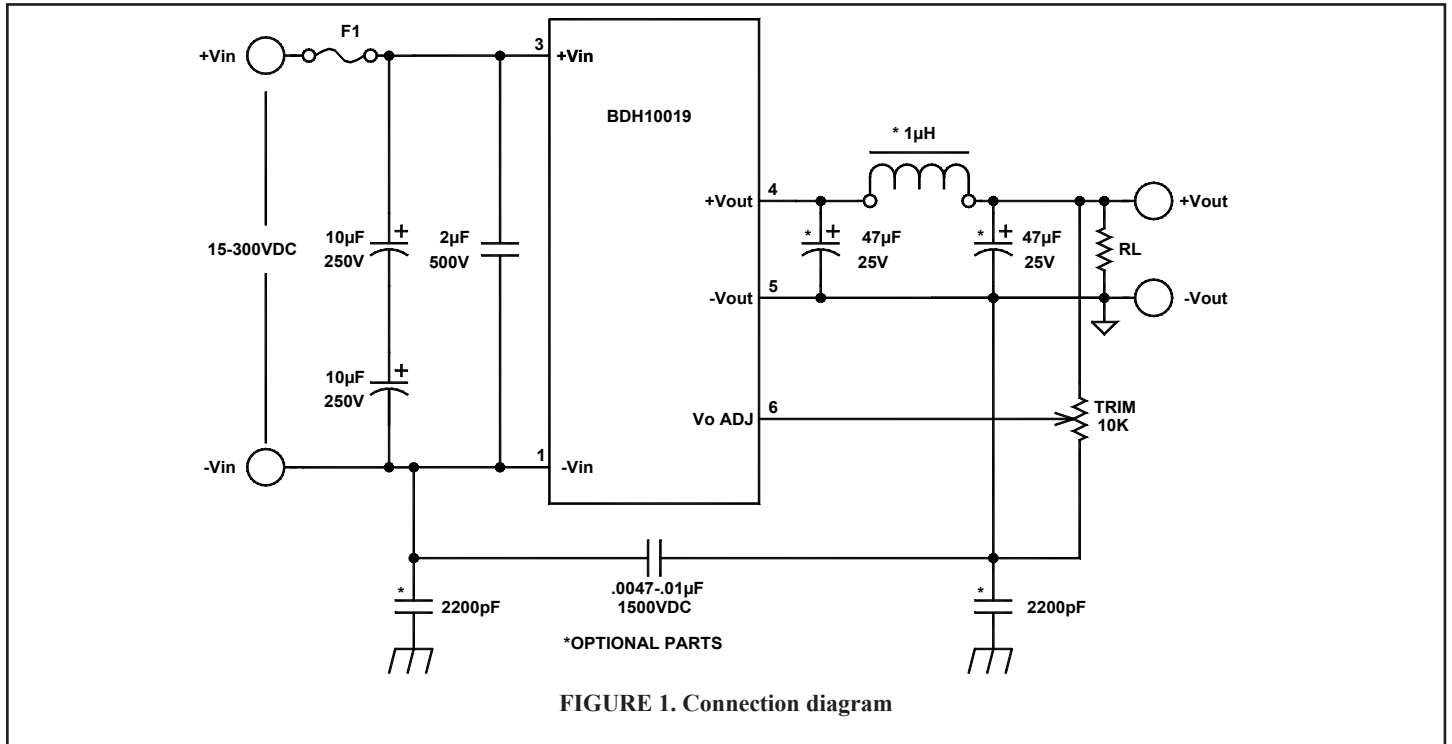

MECHANICAL SPECIFICATIONS

DIMENSIONS ARE IN INCH(mm)
 TOLERANCES: .XX ±.01(.254)
 .XXX ±.005(.127)

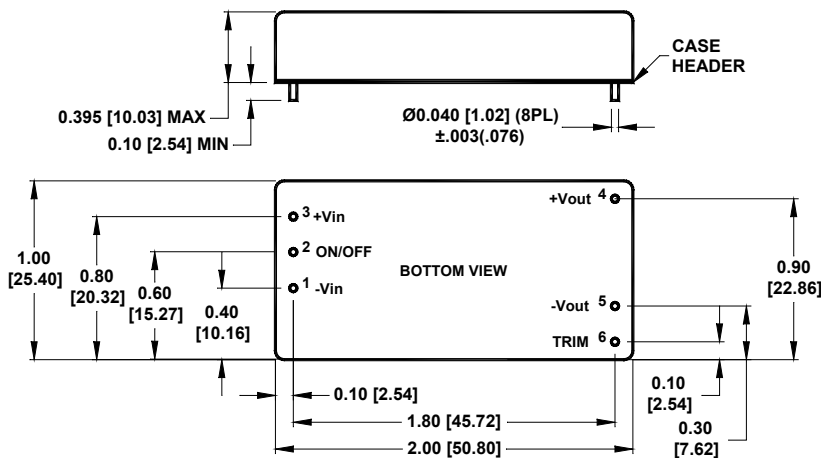

Pin	Function
1	-V _{IN}
2	NO PIN
3	+V _{IN}
4	+V _{OUT}
5	-V _{OUT}
6	TRIM

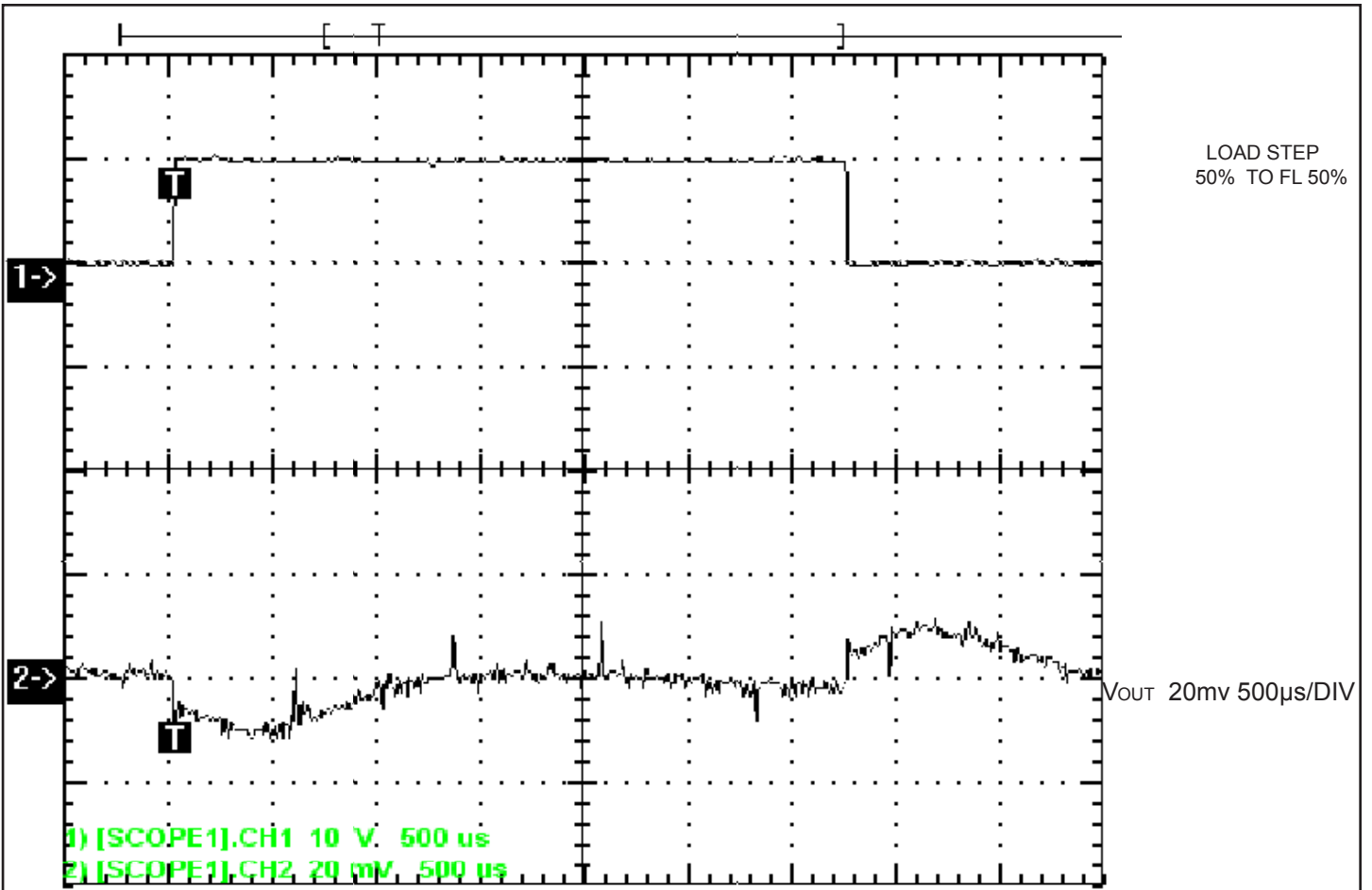

FIGURE 2.TRANSIENT RESPONSE

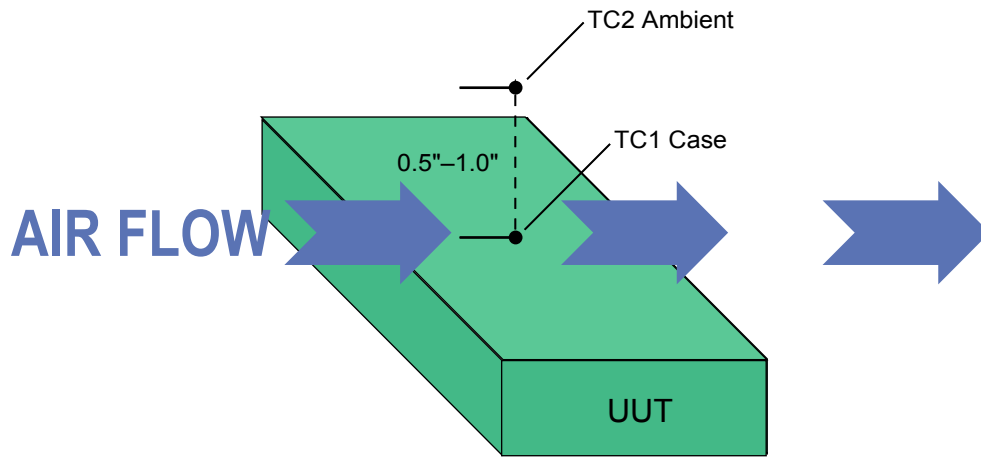

FIGURE 4. Setup for measuring case and ambient temperatures

The ambient temperature is measured with thermo-coupler #2, which is positioned 0.5"-1.0" above the center of the unit. When airflow is used, position the converter such that the 2" length of the converter is perpendicular to the airflow.