



**BDH10018**  
**15W SINGLE DC/DC CONVERTER**  
 200-300  $V_{IN}$  ( $V_{IN PEAK}$  400V) 15  $V_{OUT@1A}$

**Key Features**

- Input-to-output isolation
- Soft start
- Short circuit and thermal protection
- EMI six-sided shielding
- Frequency Jitter Modulation



**Functional Description**

The BDH10018 is a 15W single DC/DC converter in a 2x1x0.395-inch package that provides 15 $V_{OUT@1A}$  with an operating temperature range from -40°C to +85°C. Switching frequency jitter modulation reduces EMI while its six-sided shielding eliminates RFI.

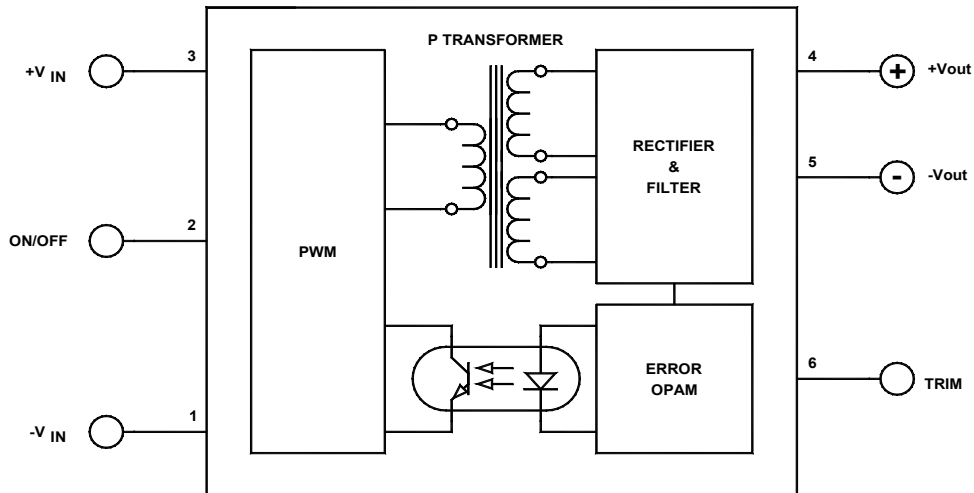

Typical Block Diagram

## Electrical Specifications

### INPUT SPECIFICATIONS

Unless otherwise specified, all parameters are given under typical +25°C with nominal input voltage and under full output load conditions.

PARAMETER	CONDITION / NOTE	MIN	TYP	MAX	UNIT
Input Voltage Range		200	270	300	Vdc
Input Voltage Slew Rate				10	V/μS
No Load Input Current	@270Vin		4.5		mA
Full Load Input Current	@270Vin		76		mA
Input Filter	NONE				
Reflected Ripple Current	Measured with 10μF input capacitor		100		mA <sub>pp</sub>
Reverse Voltage Protection	Parallel Diode		5		A
On/Off	Reference to -V <sub>IN</sub>				
Converter ON	Open		10		Vdc
Converter OFF	0V, Pin 2 (On/Off) shorted to Pin 1 (-V <sub>IN</sub> )		0	0.8	Vdc
Turn On Delay	Including soft start, See Figure 2		25	35	mS
Startup Input Voltage		150			Vdc

### OUTPUT SPECIFICATIONS

PARAMETER	CONDITION / NOTE	MIN	TYP	MAX	UNIT
Output Voltage			15.00		Vdc
Output Voltage Accuracy			1	2	%
Output Adjust Range			10		% of V <sub>out</sub>
Output Current			1		A
Ripple & Noise (20MHz BW)			.5	1	% of V <sub>OUTPP</sub>
Line Regulation	Outputs fully loaded		1		%
Load Regulation	10% FL to FL		1		%
Temperature Coefficient @ FL			±0.02		%/°C
Short Circuit Protection	Continuous, Current Limit				
Short Circuit Restart	Automatic				
Transient Response (to within 1% of Vout )	50% to 100% FL to 50% FL, see Figure 3		500		μS

### GENERAL SPECIFICATIONS

PARAMETER	CONDITION / NOTE	MIN	TYP	MAX	UNIT
Efficiency			75		%
Isolation Voltage (1 min.)		500	1000		Vdc
Isolation Resistance			10 <sup>9</sup>		Ω
Isolation Capacitance			300		pF
Switching Frequency		115	130	140	kHz
Frequency Jitter			±4		kHz
Frequency Jitter Modulation			250		Hz

### ENVIRONMENTAL SPECIFICATIONS

PARAMETER	CONDITION / NOTE	MIN	TYP	MAX	UNIT
Operating Temperature Range (Ambient)		-40		+85	°C
Storage Temperature Range		-60		+125	°C
Derating	See Figure 4				
Thermal Protection, Turn Off <sup>1</sup>	Junction Temperature		145		°C
Thermal Hysteresis			30		°C
Humidity	Up to 95% non-condensing				
Cooling	Free-air convection				
MTBF	per MIL-HNBK-217F (Ground benign, +25°)		2.045x10 <sup>6</sup>		hours

<sup>1</sup> Input power may have to be recycled after thermal turn off.

**PHYSICAL CHARACTERISTICS**

PARAMETER	CONDITION / NOTE	MIN	TYP	MAX	UNIT
Dimensions (LxWxH)	2.00x1.00x0.395 in (50.80x25.40x10.03mm)				
Weight	1.04 oz (30g)				
Case Material	Coated metal				
Shielding	Six-sided continuous				
Case Connection	-V <sub>IN</sub> (Pin 1)				

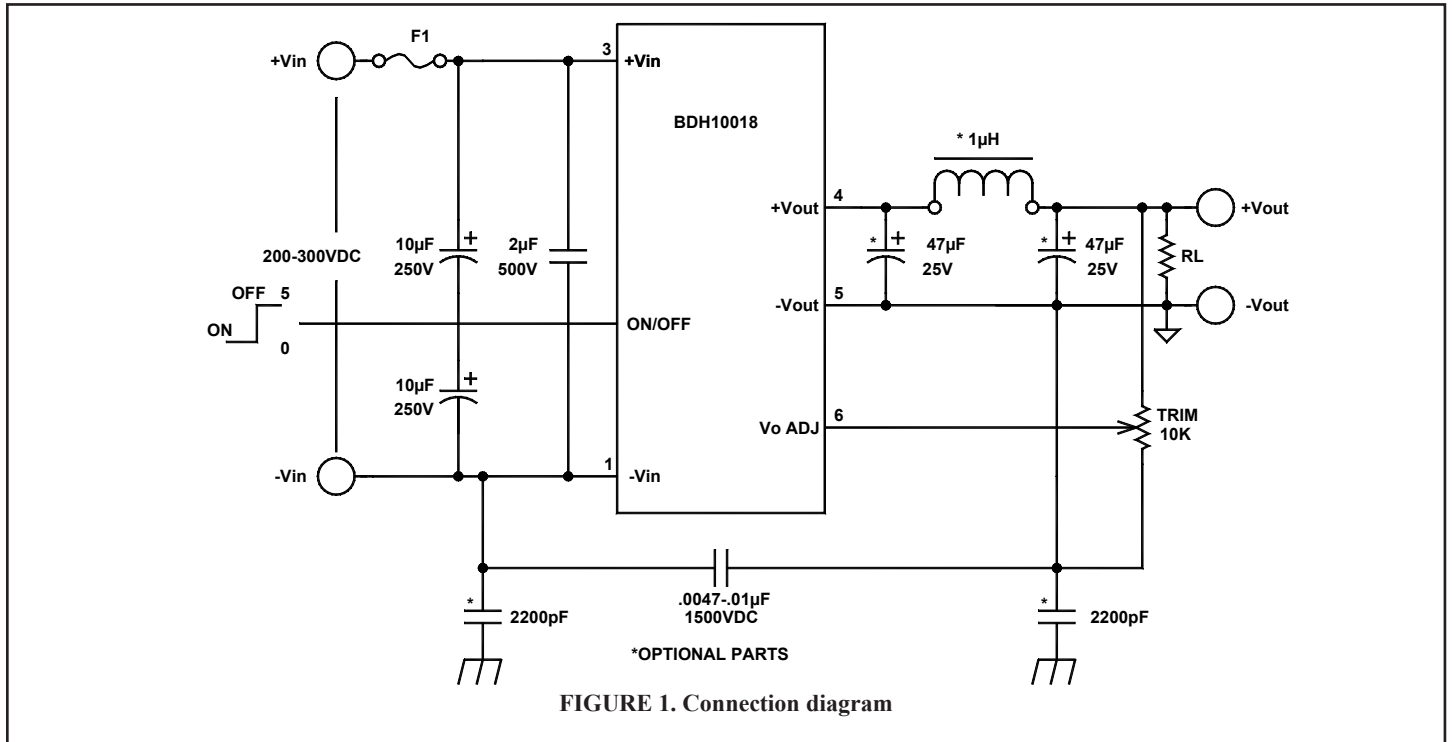

**MECHANICAL SPECIFICATIONS**

DIMENSIONS ARE IN INCH(mm)  
 TOLERANCES: .XX ±.01(.254)  
 .XXX ±.005(.127)

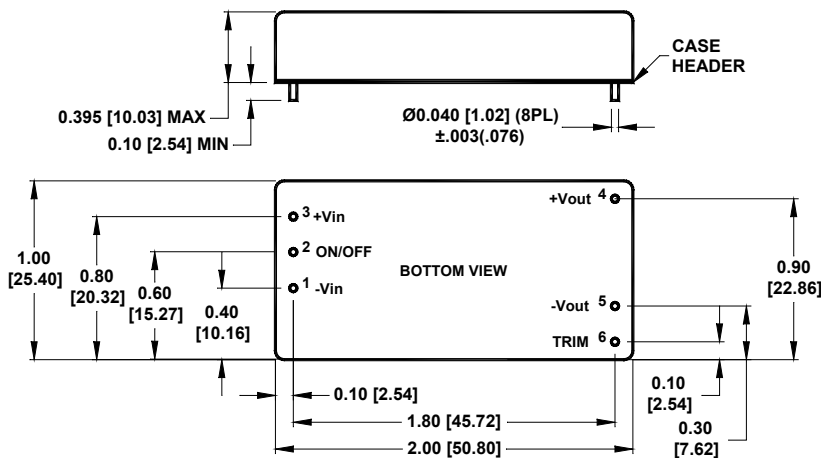

Pin	Function
1	-V <sub>IN</sub>
2	ON/OFF
3	+V <sub>IN</sub>
4	+V <sub>OUT</sub>
5	-V <sub>OUT</sub>
6	TRIM

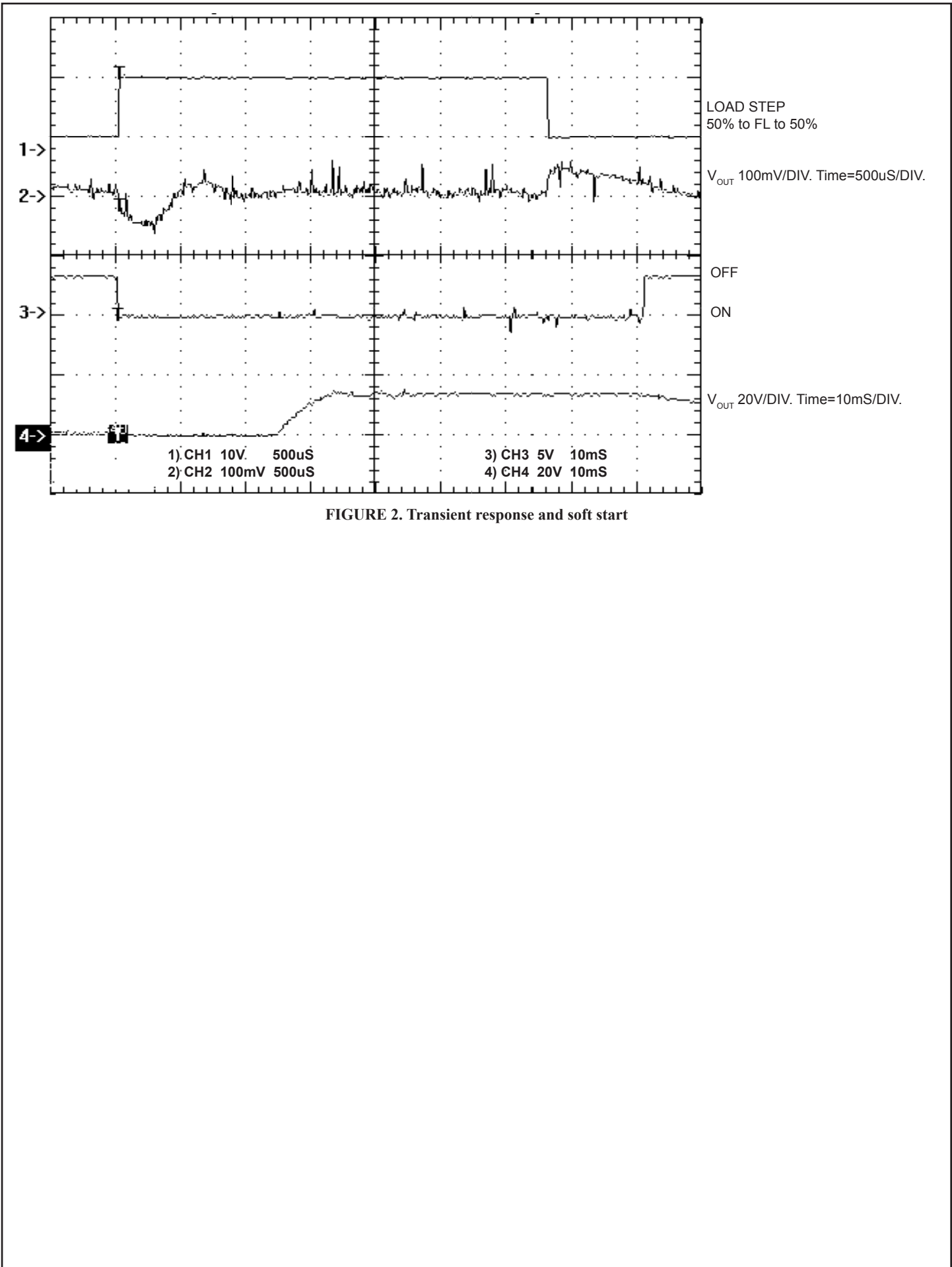
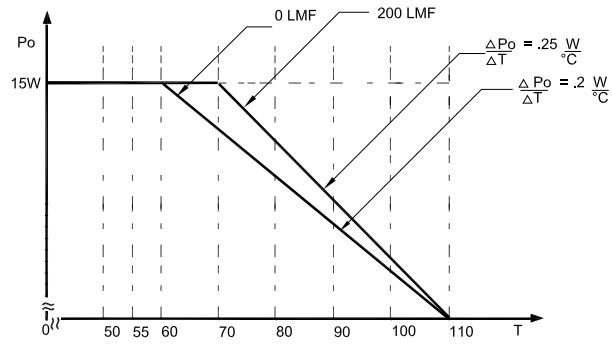
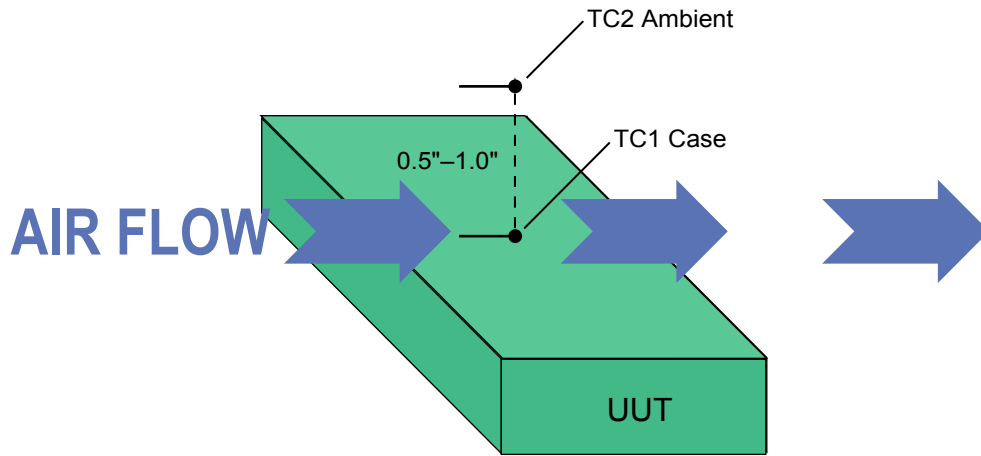

FIGURE 2. Transient response and soft start



**FIGURE 3. Derating of BDH10018**



**FIGURE 4. Setup for measuring case and ambient temperatures**

The ambient temperature is measured with thermo-coupler #2, which is positioned 0.5"-1.0" above the center of the unit. When airflow is used, position the converter such that the 2" length of the converter is perpendicular to the airflow.