



VHV15 SERIES

15W DC/DC CONVERTER

85V-400 V_{IN}, (PEAK 450V_{in}), 5V_{OUT} to 48V_{OUT} Output Range

Key Features

- Input-to-output isolation
- Soft start
- Short circuit and thermal protection
- EMI six-sided shielding
- Frequency Jitter Modulation
- Efficiency 86%
- Wide Input Range 85V-400 V_{IN}
- Adjustable Outputs



Functional Description

The VHV15 DC/DC Converter Family is designed with a wide input range, with nominal single and dual outputs. Additional features include input-to-output isolation, short circuit protection, thermal protection, soft start, adjustable outputs and efficiency up to 86%. The units are packaged in a 2x1x0.395 inch case that reduces EMI and its six-sided shielding eliminates RFI.

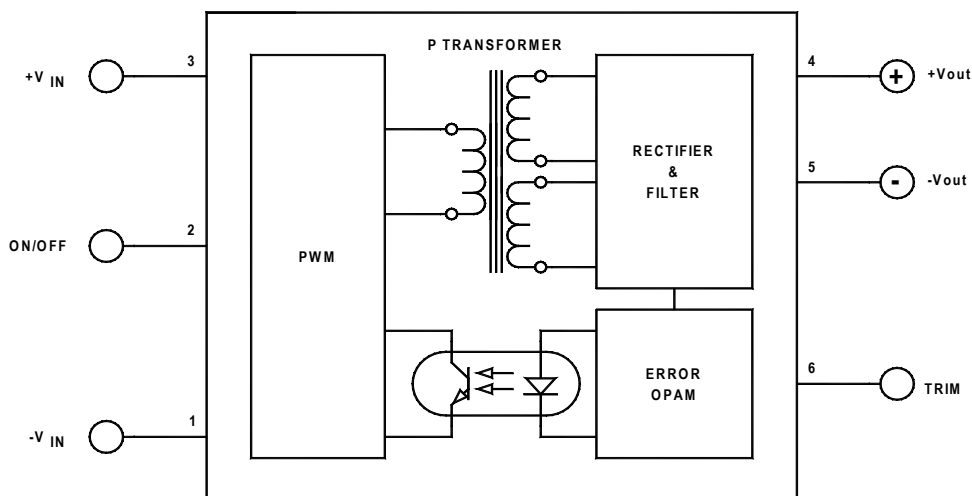

Typical Block Diagram of VHV15 Single

Unless otherwise specified, all parameters are given under typical +25°C with nominal input voltage and under full output load conditions.

Electrical Specifications

INPUT SPECIFICATIONS

PARAMETER	CONDITION/ NOTE	MIN	TYP	MAX	UNIT
Input Voltage Range	See Model Selection Guide				
No Load Input Current	See Model Selection Guide				
Full Load Input Current	See Model Selection Guide				
Input Filter	Capacitor				
Reverse Voltage Protection	Parallel Diode		5		A
On/Off	Reference to $-V_{IN}$				
Converter ON	Open		10		Vdc
Converter OFF	0V, Pin 2 (On/Off) shorted to Pin 1 ($-V_{IN}$)		0	0.8	Vdc
Turn On Delay	Including soft start		25	35	mS
Startup Input Voltage					Vdc

OUTPUT SPECIFICATIONS

PARAMETER	CONDITION / NOTE	MIN	TYP	MAX	UNIT
Output Voltage	See Model Selection Guide				
Output Voltage Accuracy			1	2	%
Output Current	See Model Selection Guide				
Ripple & Noise (20MHz BW)			1	2	% of V_{OUTP}
Line Regulation	Outputs fully loaded		1		%
Load Regulation	10% FL to FL		1		%
Temperature Coefficient @ FL			±0.02		%/°C
Short Circuit Protection	Continuous, Current Limit				
Short Circuit Restart	Automatic				
Transient Response (to within 1% of V)	50% FL to 100% FL to 50% FL		500		µS

GENERAL SPECIFICATIONS

PARAMETER	CONDITION / NOTE	MIN	TYP	MAX	UNIT
Efficiency	See Model Selection Guide				
Isolation Voltage		500	1000		Vdc
Isolation Resistance			10 ⁹		Ω
Isolation Capacitance			300		pF
Switching Frequency		115	130	140	kHz
Frequency Jitter			±4		kHz
Frequency Jitter Modulation			250		Hz

ENVIRONMENTAL SPECIFICATIONS

PARAMETER	CONDITION / NOTE	MIN	TYP	MAX	UNIT
Operating Temperature Range (Ambient)		-25		+72	°C
Storage Temperature Range		-60		+125	°C
Thermal Protection, Turn Off ¹	Junction Temperature		145		°C
Thermal Hysteresis			30		°C
Humidity	Up to 95% non-condensing				
Cooling	Free-air convection				
MTBF	per MIL-HNBK217F (Ground benign, +25')		2.5 x 10 ⁶		Hours

¹ Input power may have to be recycled after thermal turn off.

PHYSICAL CHARACTERISTICS

PARAMETER	CONDITION / NOTE	MIN	TYP	MAX	UNIT
Dimensions (LxWxH)	2.00x1.00x0.395 in. (50.80x25.40x10.03mm)				
Weight	1.04 oz. (30g)				
Case Material	Coated metal				
Shielding	Six-sided continuous				
Case Connection	+Vin (Pin 3)				

MODEL SELECTION GUIDE

MODEL NUMBER	INPUT				OUTPUT		
	Voltage (Vdc)		Current (A)		Voltage (Vdc)	Current (A)	Efficiency Full Load (%)
	Nominal	Range	No Load	Full Load			
VHV15S3/120	120	85-400	0.0011	0.1758	3.00	5.00	68
VHV15S5/120	120	85-400	0.0005	0.1563	5.00	3.00	80
VHV15S12/120	120	85-400	0.0015	0.1505	12.00	1.25	83
VHV15S15/120	120	85-400	0.0017	0.1485	15.00	1.00	84
VHV15S18/120	120	85-400	0.0022	0.1470	18.00	0.833	85
VHV15S24/120	120	85-400	0.0024	0.1452	24.00	0.625	86
VHV15S28/120	120	85-400	0.0023	0.1452	28.00	0.535	86
VHV15S48/120	120	85-400	0.0030	0.1444	48.00	0.3125	86
VHV15D5/120	120	85-400	0.0011	0.1612	±5.00	±1.500	77
VHV15D12/120	120	85-400	0.0023	0.1496	±12.00	±0.625	84
VHV15D15/120	120	85-400	0.0022	0.1484	±15.00	±0.500	84
VHV15D18/120	120	85-400	0.0027	0.1461	±18.00	±0.416	85
VHV15D24/120	120	85-400	0.0033	0.1443	±24.00	±0.312	86

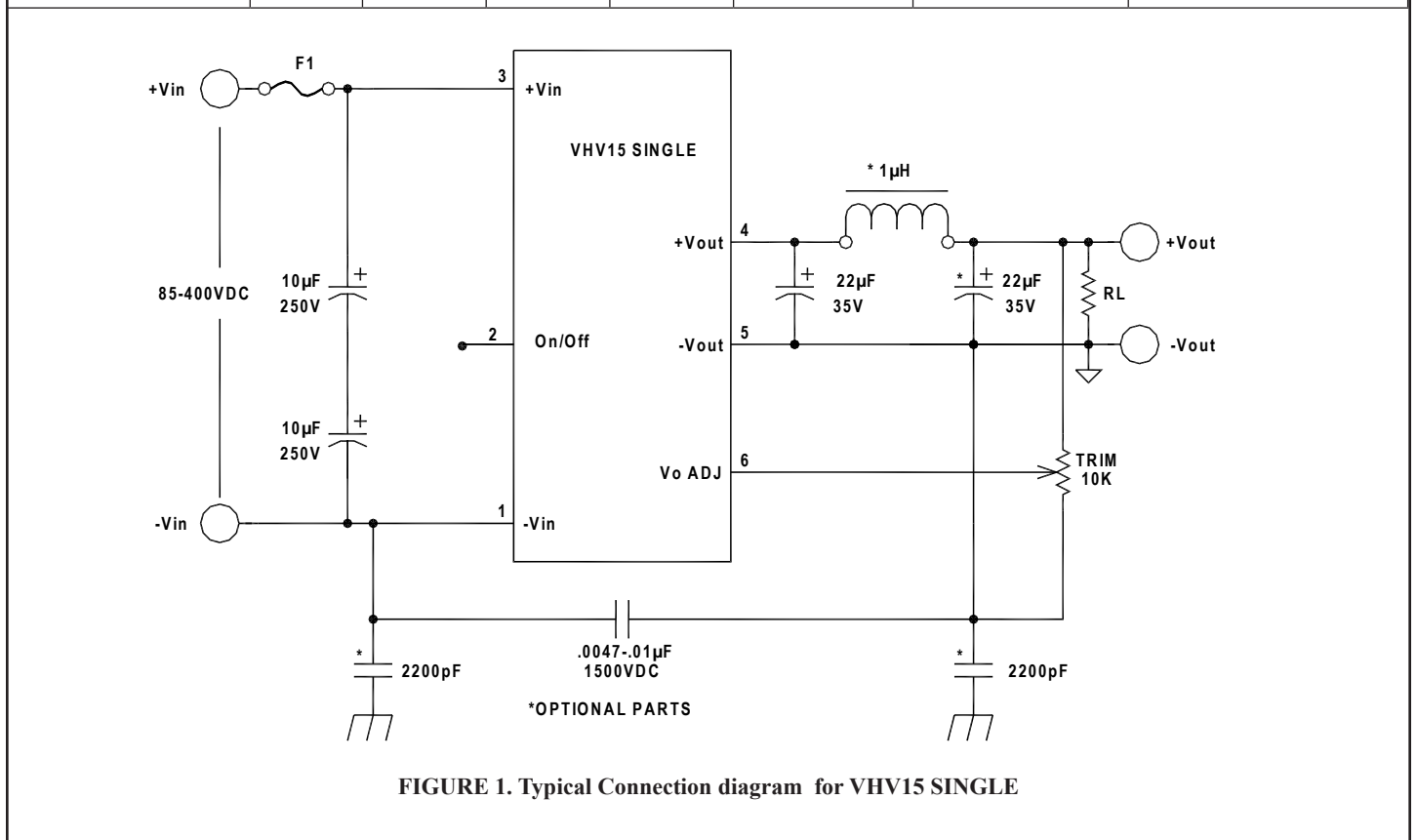

FIGURE 1. Typical Connection diagram for VHV15 SINGLE

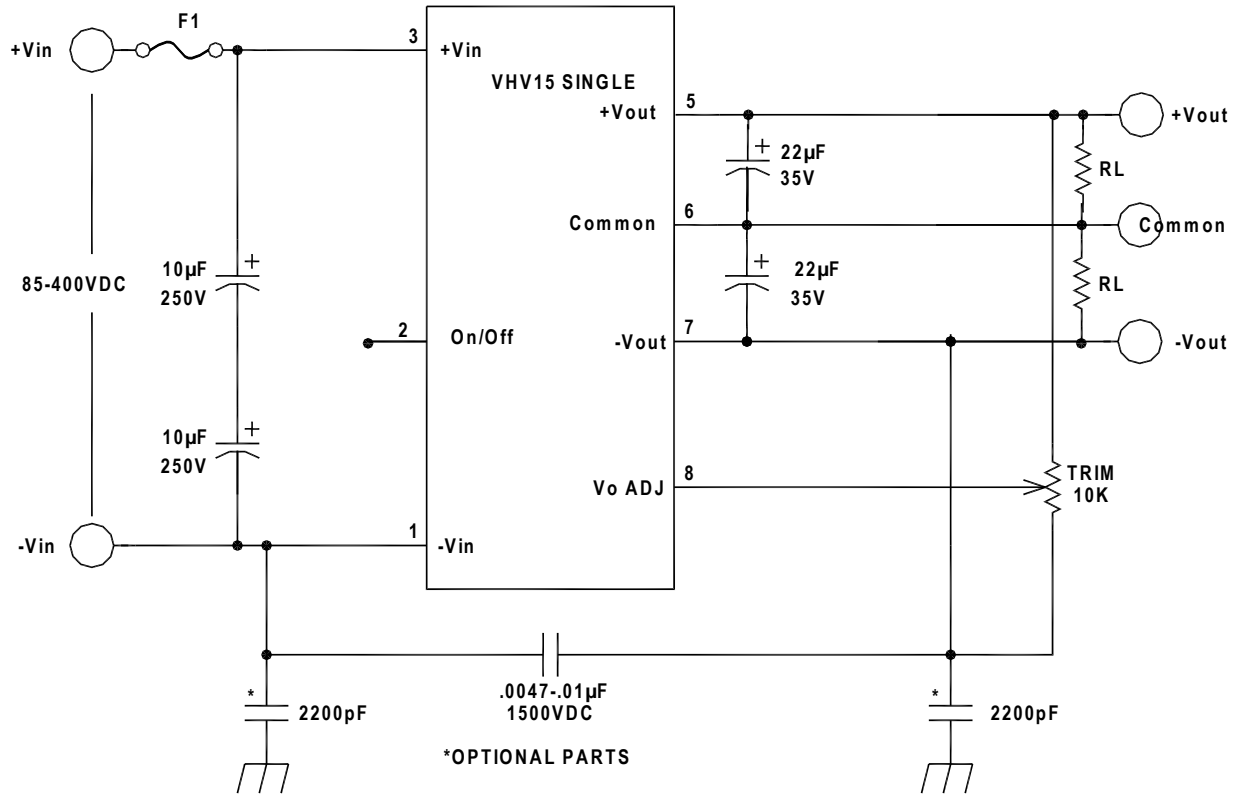

FIGURE 2. Typical Connection diagram for VHV15 DUAL

To calculate R adjust for higher Vout use

$$RT = [R1 * RF * Vref] / [(R1 * Vout) - Vref(R1 + RF)] - RA$$

where Vout is the new higher value of Vout.

See Figure 3 and 4

To calculate RT for lower Vout use

$$RT = [R1 * RF * (Vout - Vref)] / [Vref(RF + R1) - R1 * Vout] - RA$$

where Vout is the new lower value of Vout.

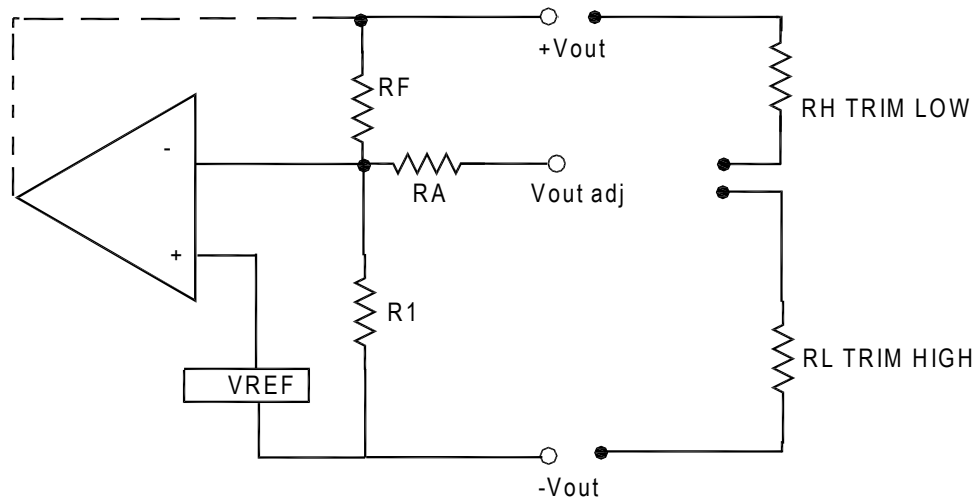

Vout	R1	RF	RA
3	2.49K	3.57K	13K
5	2.49K	2.49K	13K
12	2.49K	9.71K	22.1K
15	2.49K	12.59K	22.1K
18	2.49K	15.63K	24.3K
24	2.49K	21.57K	30.1K
28	2.55K	26.09K	18.2K
48	2.49K	45.50K	33.2K

FIGURE 3. Output voltage trim for VHV15 Single

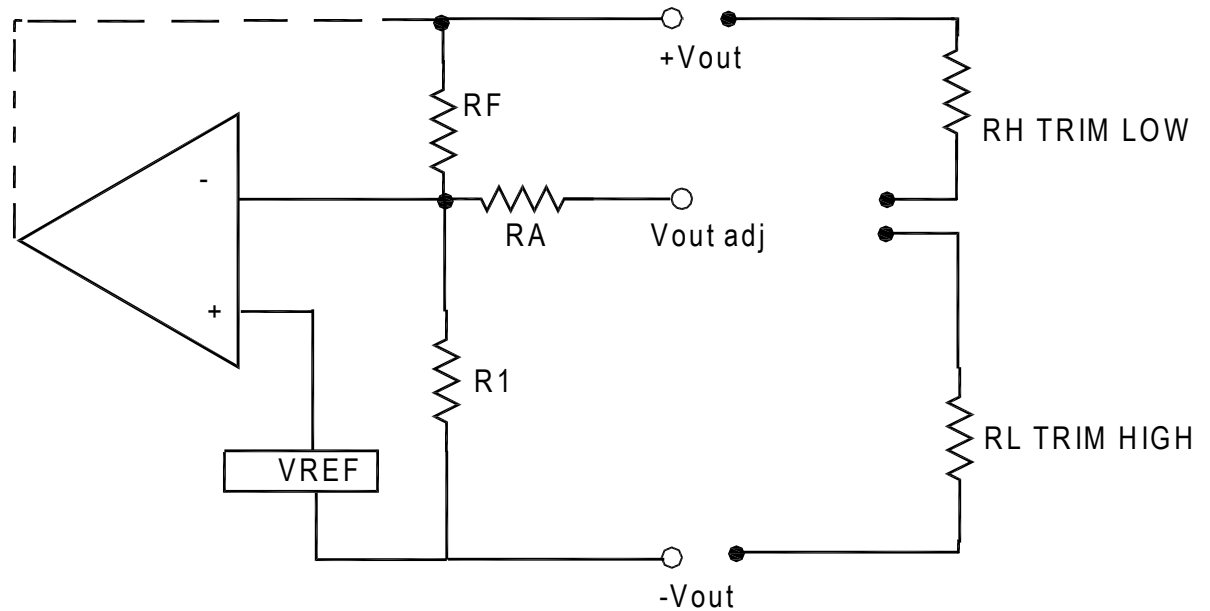

Vout	R1	RF	RA
±5	2.49K	7.50K	18.2K
±12	2.49K	21.5K	21.5K
±15	2.49K	27.4K	21.5K
±18	2.55K	33.2K	21.5K
±24	2.55K	45.3K	22.1K

FIGURE 4. Output voltage trim for VHV15 Dual

MECHANICAL SPECIFICATIONS SINGLES

DIMENSIONS ARE IN INCH(mm)
 TOLERANCES: .XX ±0.01(.254)
 .XXX ±0.005(.127)

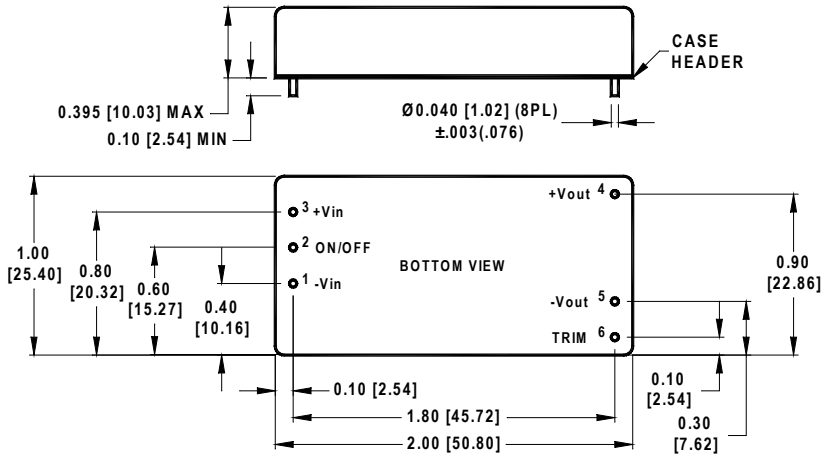

Pin	Function
1	-V _{IN}
2	ON/OFF
3	+V _{IN}
4	+V _{OUT}
5	-V _{OUT}
6	V _{OUT ADJ}

MECHANICAL SPECIFICATIONS DUALS

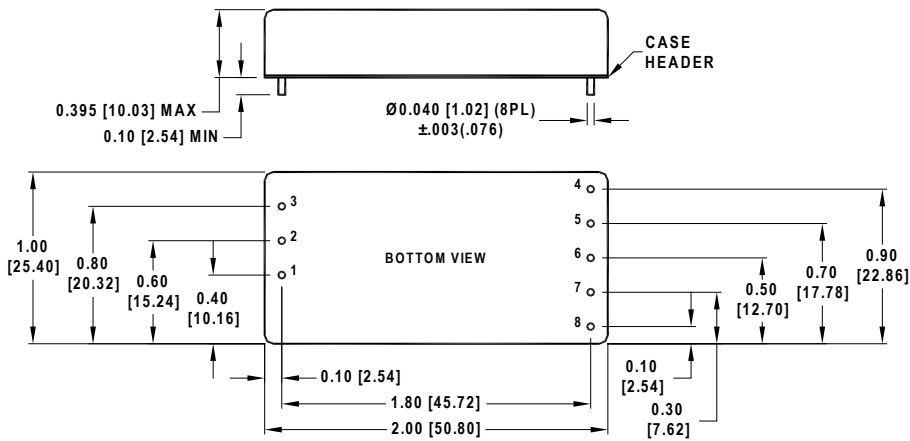

Pin	Function
1	-V _{IN}
2	ON/OFF
3	+V _{IN}
4	No Pin
5	+V _{OUT}
6	Common
7	-V _{OUT}
8	V _{OUT ADJ}