

PROTECTION

STEP-DOWN NON-ISOLATED REGULATORS

Step down regulators are used to convert a higher DC voltage to a lower required DC voltage. Switching regulators offer higher efficiency than the linear regulators, excellent load step response and higher output currents. They are also more expensive than linear regulators and produce more noise at the output. A synchronous switching step down regulator is shown in Figure 1. The PWM monitors the

output voltage V_o through feedback (FB) and adjusts the on time of Q1 in order to keep V_o constant due to the load or line variations. Q2 turns on after Q1 turns off to reduce the forward drop of D1, thus increasing the efficiency of the regulator. D1 provides a momentary path for the current through LO, RL and is used only during the switch-over time of Q1 turning off and Q2 turning on generated by the PWM.

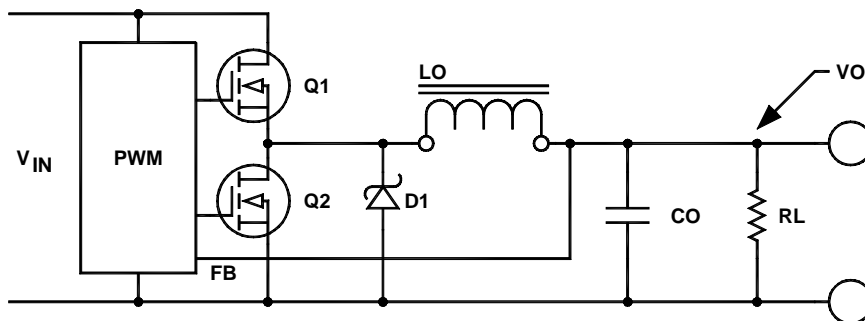

FIGURE 1

OVER VOLTAGE IN STEP-DOWN CONVERTERS

Even though most synchronous PWM IC's provide control and monitoring signals, they do not offer over voltage protection at the output because it is application dependent especially for adjustable output voltages.

In applications where the load is tolerant to an over voltage occurrence, for example, if a 5V input is converted to a $3.3V_{OUT}$ and the load can withstand 5V, over voltage

protection is not necessary. But if the input varies from 4V to 9V and provides $3.3V_{OUT}$, and the maximum output voltage must not exceed 4V, then over voltage protection is a must. The typical connection diagram in Figure 2 utilizes a zener diode for input over voltage protection and an over voltage sensor for output over voltage.

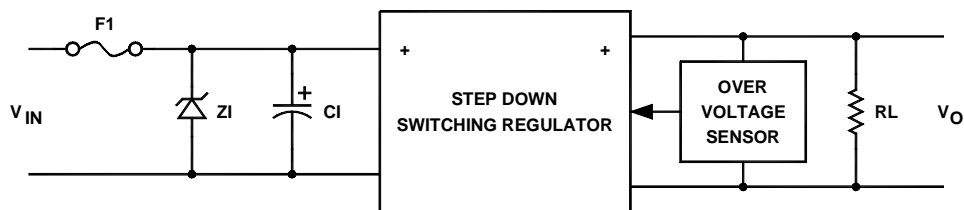

FIGURE 2

Over voltage can occur at either the input or output if the input DC voltage is generated from an unregulated DC source, such as a step-down line transformer with poor regulation in which the V_{IN} can vary from a range of more than 2:1 or in which any line transients can generate high voltage spikes.

The fuse rating must be 1.5 times the maximum input current of the regulator, which is at low input voltage. The zener rating should be 10% to 20% higher than the maximum surge power and 2 to 3 times the input power to the regulator. The input capacitor C_{IN} is recommended for providing some stress relief to the input capacitors in the regulator especially if the wire lines delivering input power to the regulator are long. The output over voltage can occur if the series switch transistor (Q1 in Figure 1) shorts and Q2 is open.

This can be the result of an open feedback loop, ther-

mal runaway, a defective PWM or other cause. Under fault conditions, the input voltage can appear at V_{OUT} and damage the output circuit even if the over voltage is only a few μ S spike. The over voltage sensor must be fast and not allow the output to exceed the maximum V_{OUT} .

In Figure 3, a 3.6V zener diode is used as an over voltage sensor in series with a 15Ω resistor. Allowing for the negative TC of the bipolar transistor, we set the V_{BE} to be 0.4V. If the maximum voltage is 4V, then $4V - 3.6V = 0.4V$ and the zener current required is $0.4/15 = 27mA$.

When an over voltage condition occurs, the bipolar transistor Q2 turns on pulling the gate of the P channel Q1 to ground. This shorts the input to ground and blows the input fuse. The $0.1\mu F$ capacitor in parallel with the 1k resistor are connected before the fuse in order to provide a small delay and assure that the P channel MOSFET DOES NOT TURN ON when power is applied to the regulator.

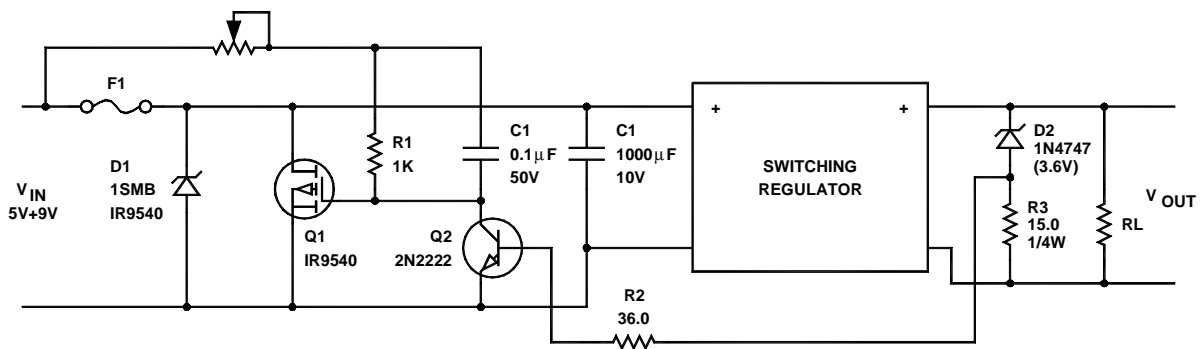

FIGURE 3

LOAD REGULATION AND GROUND LOOPS

Most switching regulator (SR) IC's used in non-isolated converters have a reference voltage and an error amplifier inside the IC that provides a feedback (FB) pin or summing point for adjusting the output. Under ideal conditions, the IC should work and provide excellent line and load regulation. But this is not the case in the real world; a circuit analysis will show why.

Let's assume we have a $5V_{IN}$ to $3.3V_{OUT}$ at I_o of 10A and the load is connected to this SR by 2-inch copper runs at a plus and minus pin for a total of 4 inches. Let's also assume the copper resistance is $0.009\Omega/in$ for a 20-gauge wire. Figure 4 shows a typical error amplifier used for regulation in the SR IC.

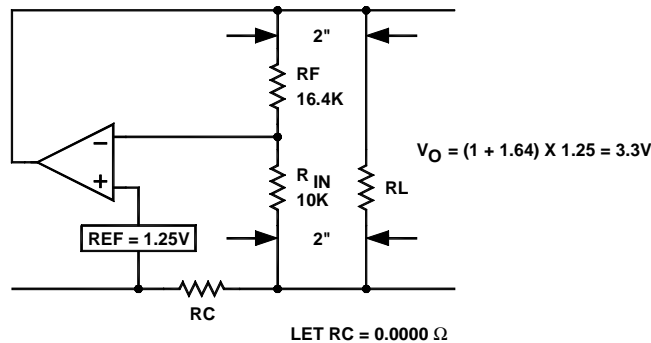

FIGURE 4

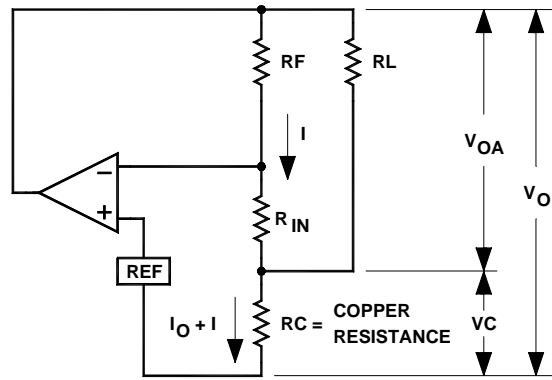

FIGURE 5

Summing the current of the minus input, we get:

$$\frac{V_{REF} - V_c}{R_{IN}} = \frac{V_o - V_{REF}}{R_F} \Rightarrow V_o = \frac{(V_{REF} - V_c)R_F}{R_{IN}} + V_{REF}$$

$$\Rightarrow V_o = V_{REF} \left(1 + \frac{R_F}{R_{IN}} \right) - V_c \frac{R_F}{R_{IN}}$$

$$V_o = V_{REF} \left(1 + \frac{R_F}{R_{IN}} \right) - I_o R_C \frac{R_F}{R_{IN}} \Rightarrow V_{OA} = V_o - V_c \frac{R_F}{R_{IN}}$$

For a 20 gauge wire with 0.86mΩ/in resistance, connect the load 2 inches away from the SR (assume the PWM is an inch away from the pins):

Positive V_{OUT} voltage drop = $(2 \times 0.00086) \times 10 = 17.2\text{mV}$

Negative V_{OUT} voltage drop = $(3 \times 0.00086) \times I_o = 0.0258 = 25.8\text{mV}$

$V_{OA} = 3.3 - (25.8\text{mV} \times 1.64) = 3.257\text{V}$

and the voltage measured across **RL = 3.254 - 17.2mV = 3.2405**

Therefore the load regulation for this switching regulator is very poor: close to 2% from no load to full load. Increasing the wire size using ground plane will improve the load regulation. However, one must be careful using ground planes for all the power components used in a board layout once it is understood that the input and output grounds are internally connected in most switching regulators and which may create ground loops, ground bouncing, etc.

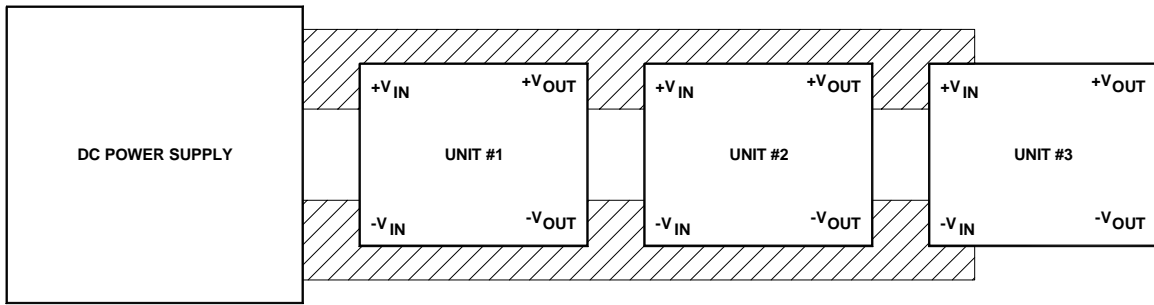

FIGURE 6A. Non-preferred layout

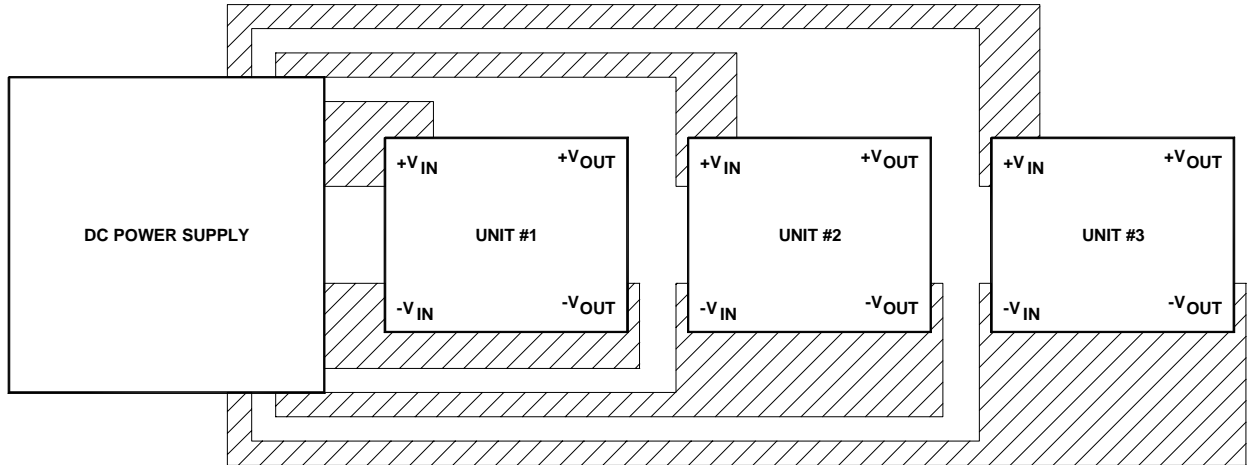

FIGURE 6B. Preferred layout

In Figure 6A, all the current from SR3 to SR1 goes through SR1 and makes SR1 useless. Use the layout in Figure 6B if possible.

If the load regulation is very critical in a given application, the circuit in Figure 6B can be used.

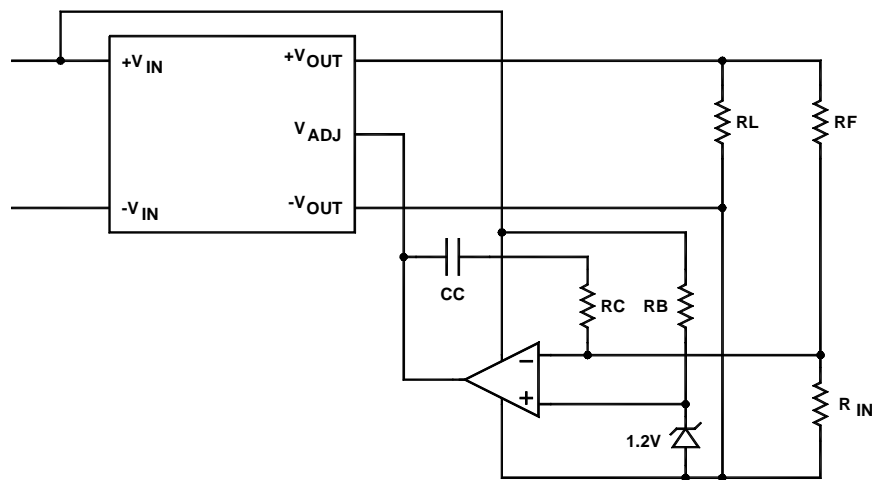

FIGURE 7

Note that the reference zener and resistors are referenced to ground at the load and any $I \times R$ drop of the negative wire runs will be automatically compensated.