



# FSR6

## 30W MAX. WIDE INPUT / WIDE OUTPUT STEP-DOWN SWITCHING REGULATORS

### Features

- 2W to 30W output power range
- Wide input voltage range ( $9V_{IN}$  to  $28V_{IN}$ )
- Wide output voltage range ( $1.8V_{OUT}$  to  $15V_{OUT}$ )
- Adjustable output voltage
- Efficiency up to 97%
- Over load protection (125% full load typical)
- Continuous short circuit protection (Low short current:  $I_{IN} < 50mA$ )
- ON/OFF Control (Ground Off)
- Non-isolation



### Electrical Specifications: Regulated

#### INPUT SPECIFICATIONS

Measured at 25°C with the condition of  $V_N$  = Nominal and Full Load. Specifications subject to change without notice.

PARAMETER	CONDITION / NOTE	MIN	TYP	MAX	UNIT
Input Voltage Range	See Model Selection Guide				
Input Filter	Capacitor (See Figures 1A & 1B)				
Shutdown Current	ON/OFF Pin pull low		100		$\mu A$
Quiescent Current	$I_O = 0A$ , Minimum $V_{IN}$ to maximum $V_{IN}$		6	10	mA
ON/OFF Control, Converter ON <sup>1</sup>	Open or high level	2.0		10	Vdc
ON/OFF Control, Converter OFF <sup>1</sup>	Low level			0.8	Vdc

#### OUTPUT SPECIFICATIONS

PARAMETER	CONDITION / NOTE	MIN	TYP	MAX	UNIT
Output Voltage	See Model Selection Guide				
Output Current	See Model Selection Guide				
Output Voltage Accuracy			$\pm 1$	$\pm 2$	%
Ripple & Noise, FSR61			40	100	mV <sub>pp</sub>
Ripple & Noise, FSR62			40	120	mV <sub>pp</sub>
Line Regulation, FSR61	Minimum $V_{IN}$ to maximum $V_{IN}$ , FL			0.5	%
Line Regulation, FSR62	Minimum $V_{IN}$ to maximum $V_{IN}$ , FL			0.5	%
Load Regulation, FSR61	10% FL to FL			0.5	%
Load Regulation, FSR62	10% FL to FL			1.0	%
Transient Response <sup>2</sup>	50% load change		100	200	$\mu S$
	$V_O$ - Over/Undershoot		5		%
Short Circuit Protection	$V_{IN} \geq 12V$	20		100	mA

#### GENERAL SPECIFICATIONS

PARAMETER	CONDITION / NOTE	MIN	TYP	MAX	UNIT
Efficiency @ FL	See Model Selection Guide				
Switching Frequency		200	250	300	kHz

#### ENVIRONMENTAL SPECIFICATIONS

PARAMETER	CONDITION / NOTE	MIN	TYP	MAX	UNIT
Operating Temperature Range	Ambient	-40		+85	°C
Operating Case Temperature			+100	+110	°C
Storage Temperature Range		-40		+125	°C

#### PHYSICAL CHARACTERISTICS

PARAMETER	CONDITION / NOTE	MIN	TYP	MAX	UNIT
Dimensions (L×W×H)	1.27×0.59×0.36 in. (32.20×15.00×9.10mm)				
Weight	0.32 oz. (9.0g)				

<sup>1</sup> ON/OFF pin driven by open collector of bipolar transistor or open drain of MOSFET or TTL (logic gate).

<sup>2</sup> Measured with a 100 $\mu F$  electrolytic or tantalum output capacitor (placed as close as possible to output pins) for proper operation in all applications.

**MODEL SELECTION GUIDE**

(NOTE: If the adjust function is used:  $V_{IN} - V_{OUT} \geq 1.5V$ . Contact factory for custom input & output voltages.)

MODEL NUMBER	MAX OUTPUT POWER (W)	OUTPUT VOLTAGE (Vdc)	V <sub>O</sub> ADJUST RANGE (Vdc)	OUTPUT CURRENT (A)	INPUT VOLTAGE (Vdc)		EFFICIENCY (%)	
					MIN	MAX	MIN V <sub>IN</sub>	MAX V <sub>IN</sub>
FSR613.3P/D	6	3.3	1.8–6.0	1	9	28	88	81
FSR615.0P/D	9	5.0	1.8–9.0	1	9	28	92	86
FSR619.0P/D	15	9.0	3.3–15.0	1	11	28	96	89
FSR6112P/D	15	12.0	3.3–15.0	1	14	28	97	94
FSR623.3P/D	12	3.3	1.8–6.0	2	9	28	86	82
FSR625.0P/D	18	5.0	1.8–9.0	2	9	28	90	87
FSR629.0P/D	30	9.0	3.3–15.0	2	11	28	95	92
FSR6212P/D	30	12.0	3.3–15.0	2	14	28	96	94

**ORDERING GUIDE**

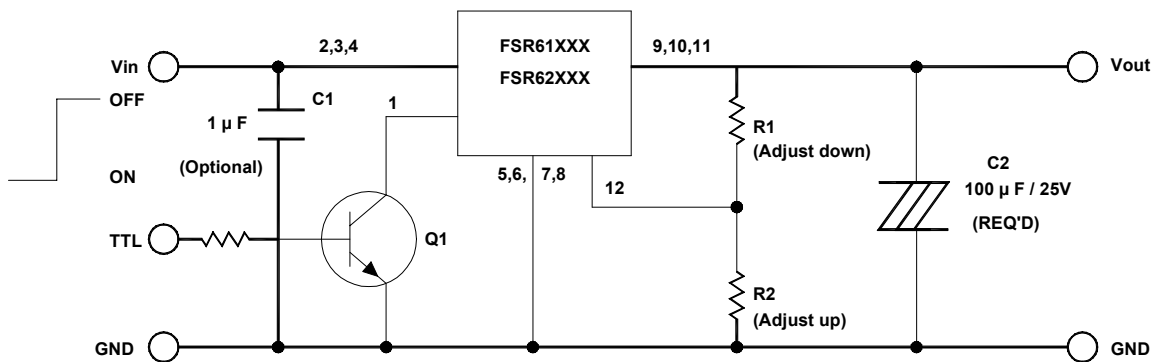
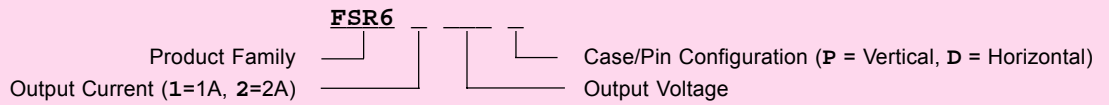

Q1: Transistor or MOSFET ( $V_{CE}$  or  $V_{DS} > 25Vdc$ )

**FIGURE 1. Standard application circuit**

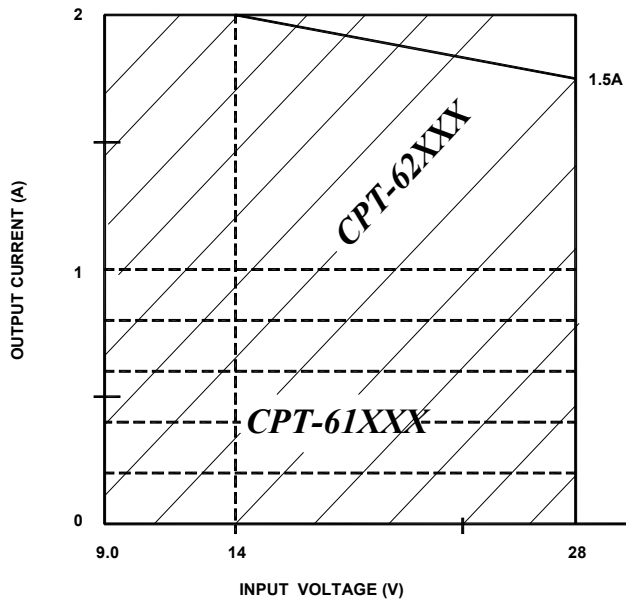

FIGURE 2. Output Current vs. Input Voltage

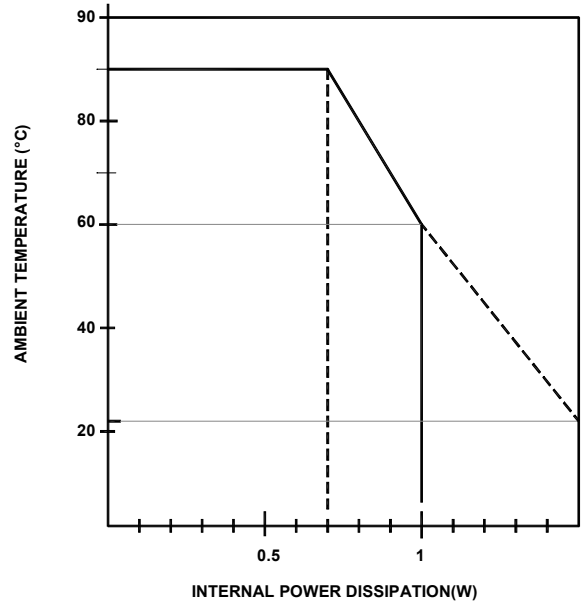

FIGURE 2. Derating curve

**How to Calculate Maximum Output Current**

The internal Power Dissipation ( $P_D$ ) can be calculated by:

$$P_D = V_o * I_o * (1-\eta)$$

$$I_o = P_D / V_o * (1-\eta)$$

Where  $P_D$  = Internal power dissipation  
 $I_o$  = Output current  
 $V_o$  = Output voltage  
 $\eta$  = Efficiency

**Examples:**

(a) FSR6212P at  $V_{IN}=28Vdc$ ,  $V_o=12Vdc$ ,  $\eta=94\%$  (See Table 1)  
 $I_o = 1(W) / 12(V) * (1-0.94) = 1.388(A) \approx 1.5(A)$

(b) FSR6212P at  $V_{IN}=14Vdc$ ,  $V_o=12Vdc$ ,  $\eta=96\%$  (See Table 1)  
 $I_o = 1(W) / 12(V) * (1-0.96) = 2.08(A)$  (spec = 2A Max)

# Mechanical Specifications

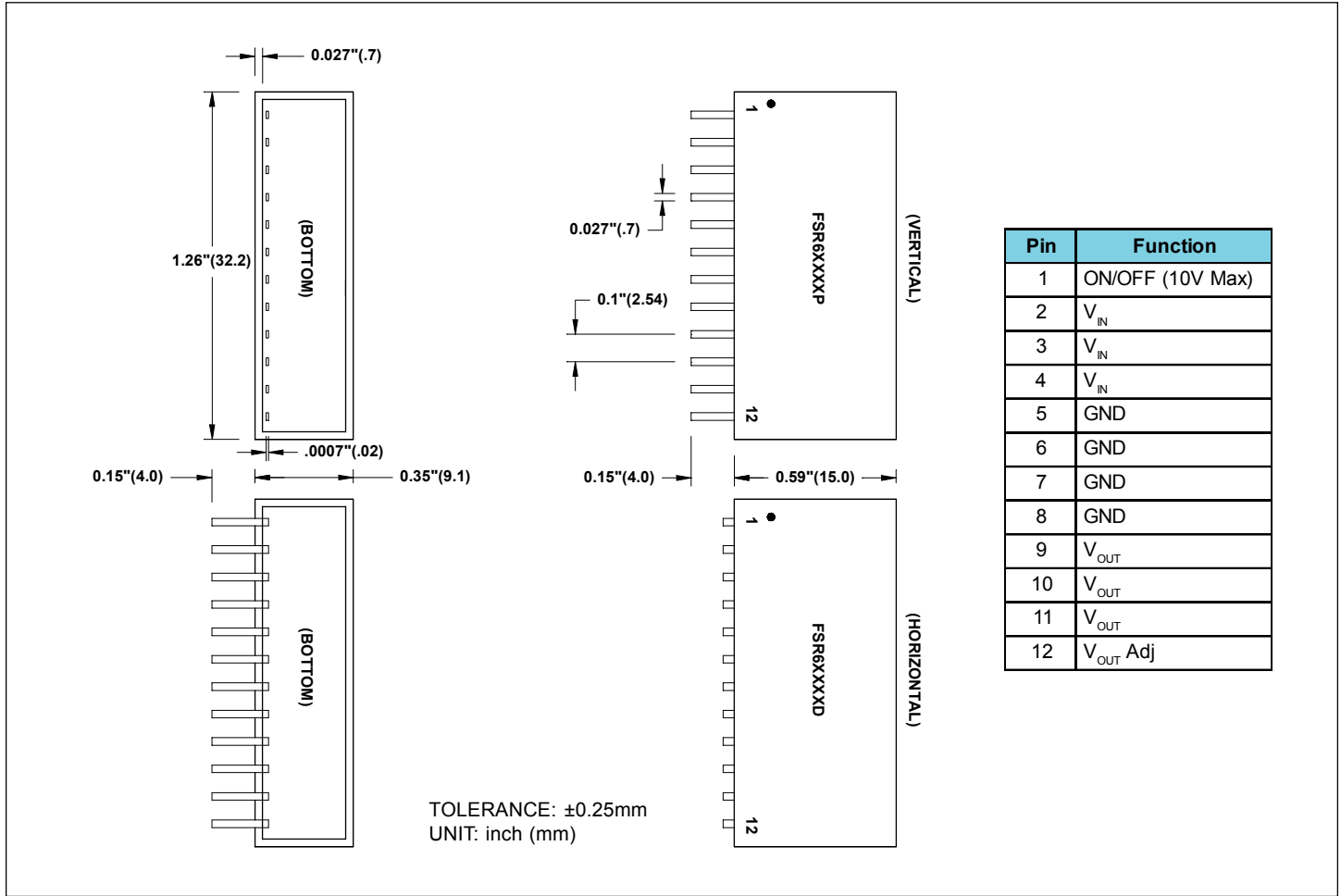

Pin	Function
1	ON/OFF (10V Max)
2	V <sub>IN</sub>
3	V <sub>IN</sub>
4	V <sub>IN</sub>
5	GND
6	GND
7	GND
8	GND
9	V <sub>OUT</sub>
10	V <sub>OUT</sub>
11	V <sub>OUT</sub>
12	V <sub>OUT</sub> Adj

**TABLE 1. Adjust output voltage vs. R1/R2 values**

1A	FSR613.3P/D		FSR615.0P/D		FSR619.0P/D		FSR6112P/D	
2A	FSR623.3P/D		FSR625.0P/D		FSR629.0P/D		FSR6212P/D	
V <sub>OUT</sub> (Nom)	3.3Vdc		5.0Vdc		9.0Vdc		12Vdc	
V <sub>OUT</sub> (Adj)	R1	R2	R1	R2	R1	R2	R1	R2
1.8V	3.1KΩ	-	820Ω	-	-	-	-	-
2.0V	5.1KΩ	-	1.5KΩ	-	-	-	-	-
2.5V	13KΩ	-	3.6KΩ	-	-	-	-	-
3.0V	51KΩ	-	7.0KΩ	-	-	-	-	-
3.3V	-	-	9.7KΩ	-	0Ω	-	0Ω	-
3.6V	-	18KΩ	14KΩ	-	1.5KΩ	-	560Ω	-
3.9V	-	9.1KΩ	20KΩ	-	3.3KΩ	-	1.2KΩ	-
4.5V	-	3.9KΩ	60KΩ	-	7.5KΩ	-	2.1KΩ	-
5.0V	-	2.4KΩ	-	-	11KΩ	-	4.0KΩ	-
5.1V	-	2.2KΩ	-	60KΩ	12KΩ	-	4.3KΩ	-
5.5V	-	1.6KΩ	-	15KΩ	17KΩ	-	5.6KΩ	-
6.0V	-	1.1KΩ	-	7.2KΩ	24KΩ	-	7.5KΩ	-
7.0V	-	-	-	2.8KΩ	51KΩ	-	12KΩ	-
8.0V	-	-	-	1.5KΩ	130KΩ	-	19KΩ	-
9.0V	-	-	-	880Ω	-	-	31KΩ	-
10V	-	-	-	450Ω	-	36KΩ	55KΩ	-
11V	-	-	-	180Ω	-	15KΩ	125KΩ	-
12V	-	-	-	-	-	8.2KΩ	-	-
13V	-	-	-	-	-	4.7KΩ	-	11KΩ
14V	-	-	-	-	-	2.7KΩ	-	4.0KΩ
15V	-	-	-	-	-	1.3KΩ	-	1.6KΩ