



FSR5

WIDE INPUT / WIDE OUTPUT STEP-DOWN SWITCHING REGULATORS

Features

- 2W to 22W output power range
- Wide input voltage range ($4.5V_{IN}$ to $18V_{IN}$)
- Wide output voltage range ($1.0V_{OUT}$ to $5.5V_{OUT}$)
- Adjustable output voltage
- Efficiency up to 96%
- Over load protection (125% full load typical)
- Continuous short circuit protection (Low short current: $I_{IN} < 50mA$)
- Remote ON/OFF Control
- Non-isolation
- Optional Auto Sense feature

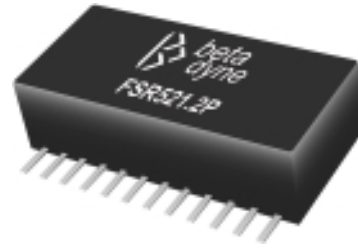

Electrical Specifications: Regulated

INPUT SPECIFICATIONS

Measured at 25°C with the condition of V_N = Nominal and Full Load. Specifications subject to change without notice.

PARAMETER	CONDITION / NOTE	MIN	TYP	MAX	UNIT
Input Voltage Range	See Model Selection Guide				
Input Filter	Capacitor (See Figures 1A & 1B)				
Shutdown Current	ON/OFF Pin pull low			100	μA
Quiescent Current	$I_O = 0A$, Minimum V_{IN} to maximum V_{IN}			20	mA
Remote ON/OFF Control, Converter ON ¹	Open	4.5		18	Vdc
Remote ON/OFF Control, Converter OFF ¹	Low level			0.8	Vdc

OUTPUT SPECIFICATIONS

PARAMETER	CONDITION / NOTE	MIN	TYP	MAX	UNIT
Output Voltage	See Model Selection Guide				
Output Current	See Model Selection Guide				
Output Voltage Accuracy			± 1	± 2	%
Ripple & Noise, FSR52			40	70	mV _{pp}
Ripple & Noise, FSR53 & FSR54			80	120	mV _{pp}
Line Regulation, FSR52	Minimum V_{IN} to maximum V_{IN} , FL		0.25	0.5	%
Line Regulation, FSR53 & FSR54	Minimum V_{IN} to maximum V_{IN} , FL		0.5	1.0	%
Load Regulation, FSR52	10% FL to FL		0.5	1.0	%
Load Regulation, FSR53 & FSR54	10% FL to FL		1.0	2.0	%
Transient Response ²	50% load change		100	200	μS
	V_O - Over/Undershoot			100	mV
Short Circuit Protection				50	mA

GENERAL SPECIFICATIONS

PARAMETER	CONDITION / NOTE	MIN	TYP	MAX	UNIT
Efficiency @ FL	See Model Selection Guide				
Switching Frequency		270	300	330	kHz

ENVIRONMENTAL SPECIFICATIONS

PARAMETER	CONDITION / NOTE	MIN	TYP	MAX	UNIT
Operating Temperature Range	Ambient	-40		+85	$^{\circ}C$
Operating Case Temperature			+100	+110	$^{\circ}C$
Storage Temperature Range		-40		+125	$^{\circ}C$

PHYSICAL CHARACTERISTICS

PARAMETER	CONDITION / NOTE	MIN	TYP	MAX	UNIT
Dimensions (L×W×H)	1.27×0.59×0.36 in. (32.20×15.00×9.10mm)				
Weight	0.32 oz. (9.0g)				

¹ ON/OFF pin driven by open collector of bipolar transistor or open drain of MOSFET.

² Measured with a 100 μF electrolytic or tantalum output capacitor (placed as close as possible to output pins) for proper operation in all applications.

MODEL SELECTION GUIDE

(NOTE: If the adjust function is used: $V_{IN} - V_{OUT} \geq 1.5V$. Contact factory for custom input & output voltages.)

MODEL NUMBER	MAX OUTPUT POWER (W)	OUTPUT VOLTAGE (Vdc)	V _O ADJUST RANGE (Vdc)	OUTPUT CURRENT (A)	INPUT VOLTAGE (Vdc)		EFFICIENCY (%)		
					MIN	MAX	MIN V _{IN}	12V _{IN}	MAX V _{IN}
FSR521.2P/D	6	1.2	1.0-3.0	2	4.5	18	83	79	75
FSR521.8P/D	9	1.8	1.1-4.5	2	4.5	18	88	85	82
FSR522.5P/D	11	2.5	1.6-5.5	2	4.5	18	91	88	86
FSR523.3P/D	11	3.3	1.6-5.5	2	4.5	18	92	90	89
FSR525.0P/D	11	5.0	3.0-5.5	2	6.5	18	95	93	92
FSR531.2P/D	9	1.2	1.0-3.0	3	4.5	18	85	84	82
FSR531.8P/D	14	1.8	1.1-4.5	3	4.5	18	89	88	86
FSR532.5P/D	17	2.5	1.6-5.5	3	4.5	18	92	91	89
FSR533.3P/D	17	3.3	1.6-5.5	3	4.5	18	94	93	92
FSR535.0P/D	17	5.0	3.0-5.5	3	6.5	18	96	95	94
FSR541.2P/D	12	1.2	1.0-3.0	4	4.5	18	82	81	79
FSR541.8P/D	18	1.8	1.1-4.5	4	4.5	18	87	86	85
FSR542.5P/D	22	2.5	1.6-5.5	4	4.5	18	91	89	88
FSR543.3P/D	22	3.3	1.6-5.5	4	4.5	18	93	92	91
FSR545.0P/D	22	5.0	3.0-5.5	4	6.5	18	95	94	93

ORDERING GUIDE

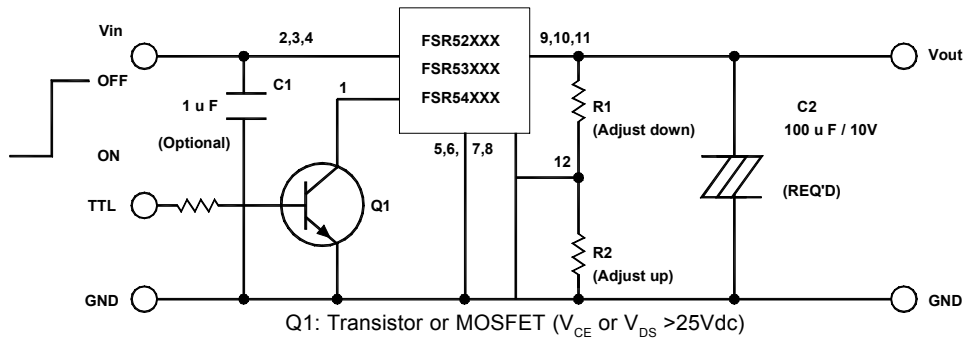
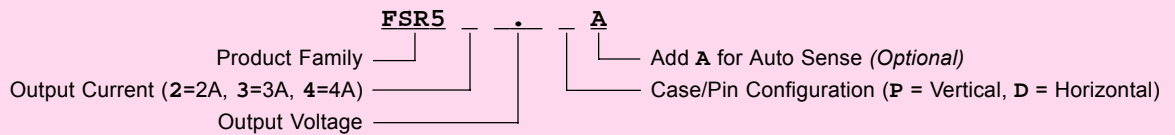

FIGURE 1A. Standard application circuit without optional Auto Sense feature

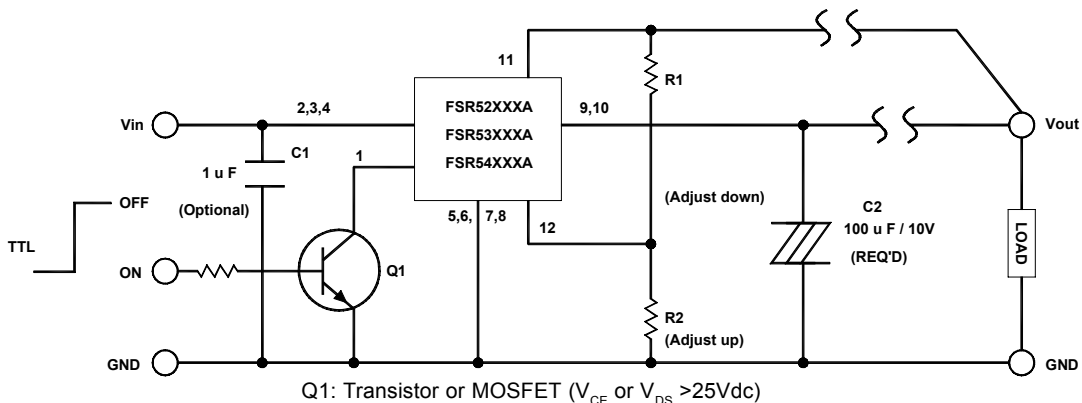

FIGURE 1B. Standard application circuit with optional Auto Sense feature

How to Calculate Maximum Output Current

The internal Power Dissipation (P_D) can be calculated by:

$$P_D = V_o * I_o * (1-\eta)$$

$$I_o = P_D / V_o * (1-\eta)$$

Where P_D = Internal power dissipation

I_o = Output current

V_o = Output voltage

η = Efficiency

T_a = Ambient temperature

Example: FSR545.0A at V_{IN} =18Vdc, V_o =5Vdc, η =93% (See Table 1)

(a) When T_a =60°C, P_D =1.4W (See Figure 1)

$$I_o = 1.4(W) / 5(V) * (1-0.93) = 4(A)$$

(b) When T_a =85°C, P_D =1W (See Figure 1)

$$I_o = 1(W) / 5(V) * (1-0.93) = 2.857(A)$$

(c) At V_{IN} =12Vdc, Efficiency = 94% (See Table 1)

When T_a =85°C, P_D =1W (See Figure 1)

$$I_o = 1(W) / 5(V) * (1-0.94) = 3.33(A)$$

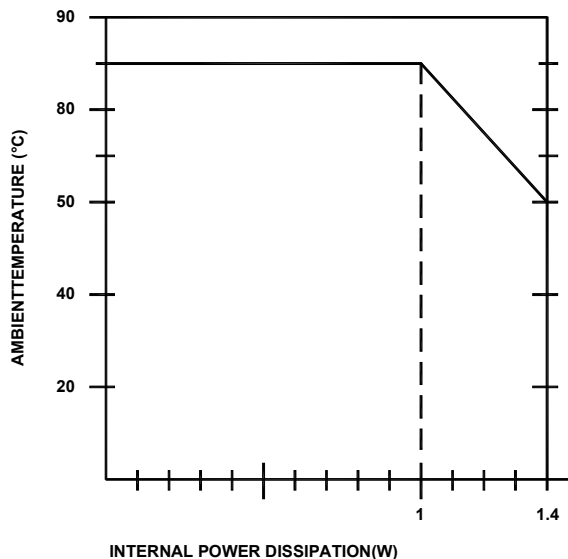

FIGURE 2. Derating curve

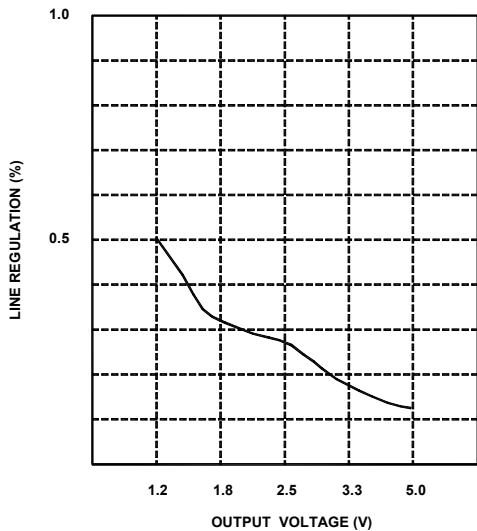

FIGURE 3A. Line regulation vs. V_{OUT} (FSR52)

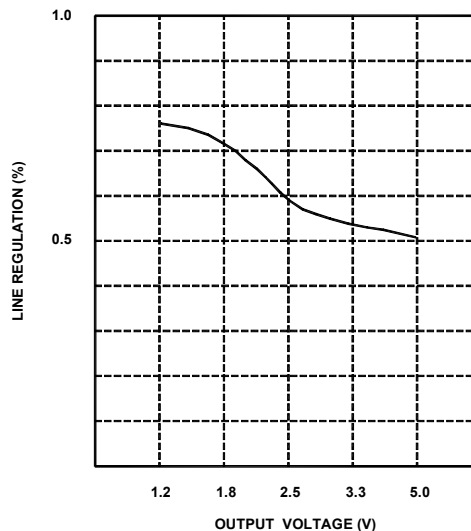

FIGURE 3B. Line regulation vs. V_{OUT} (FSR53 & FSR54)

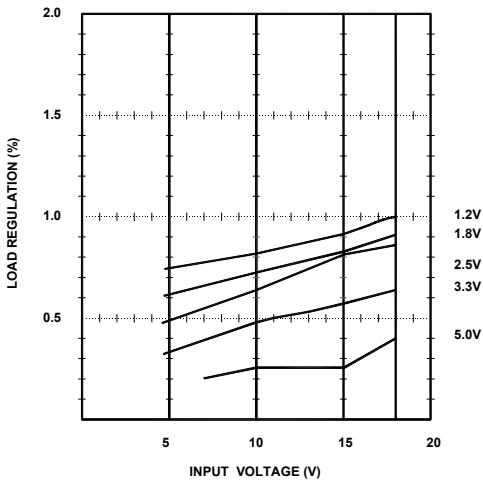

FIGURE 4A. Load regulation vs. V_{IN} (FSR52)

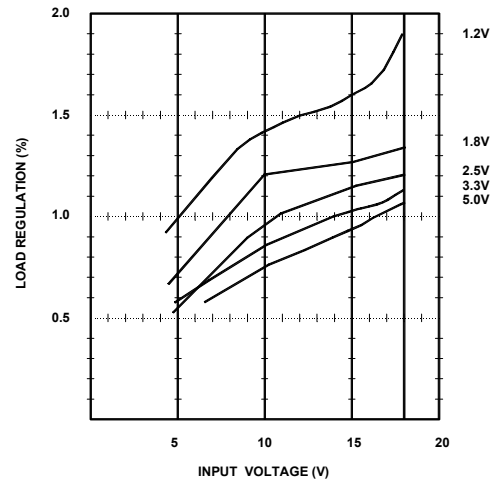

FIGURE 4B. Load regulation vs. V_{IN} (FSR53 & FSR54)

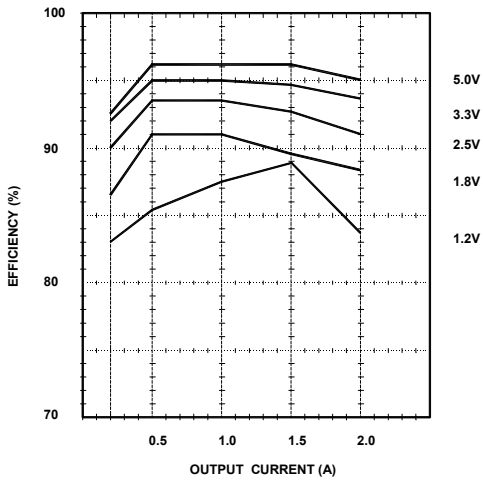

FIGURE 5A. Efficiency vs. I_O ($V_{IN} = \text{Min}$) (FSR52)

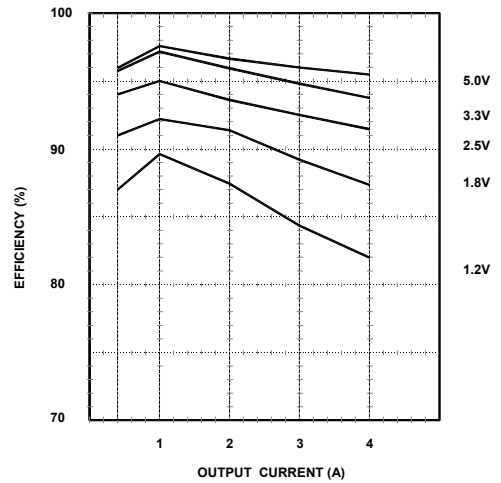

FIGURE 5B. Efficiency vs. I_O ($V_{IN} = \text{Min}$) (FSR53 & FSR54)

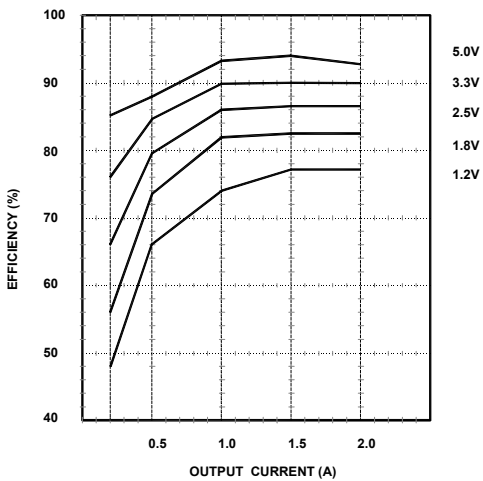

FIGURE 6A. Efficiency vs. I_O ($V_{IN} = 18V$) (FSR52)

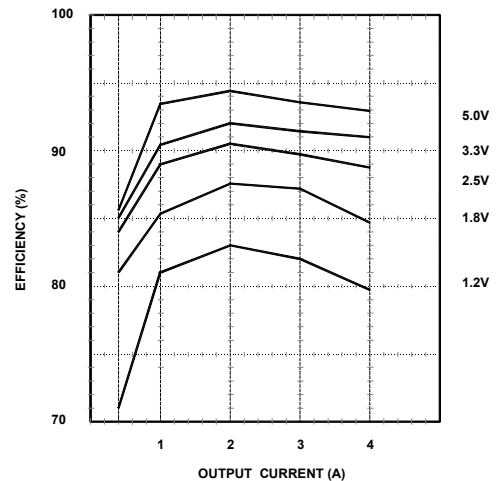

FIGURE 6B. Efficiency vs. I_O ($V_{IN} = 18V$) (FSR53 & FSR54)

Mechanical Specifications

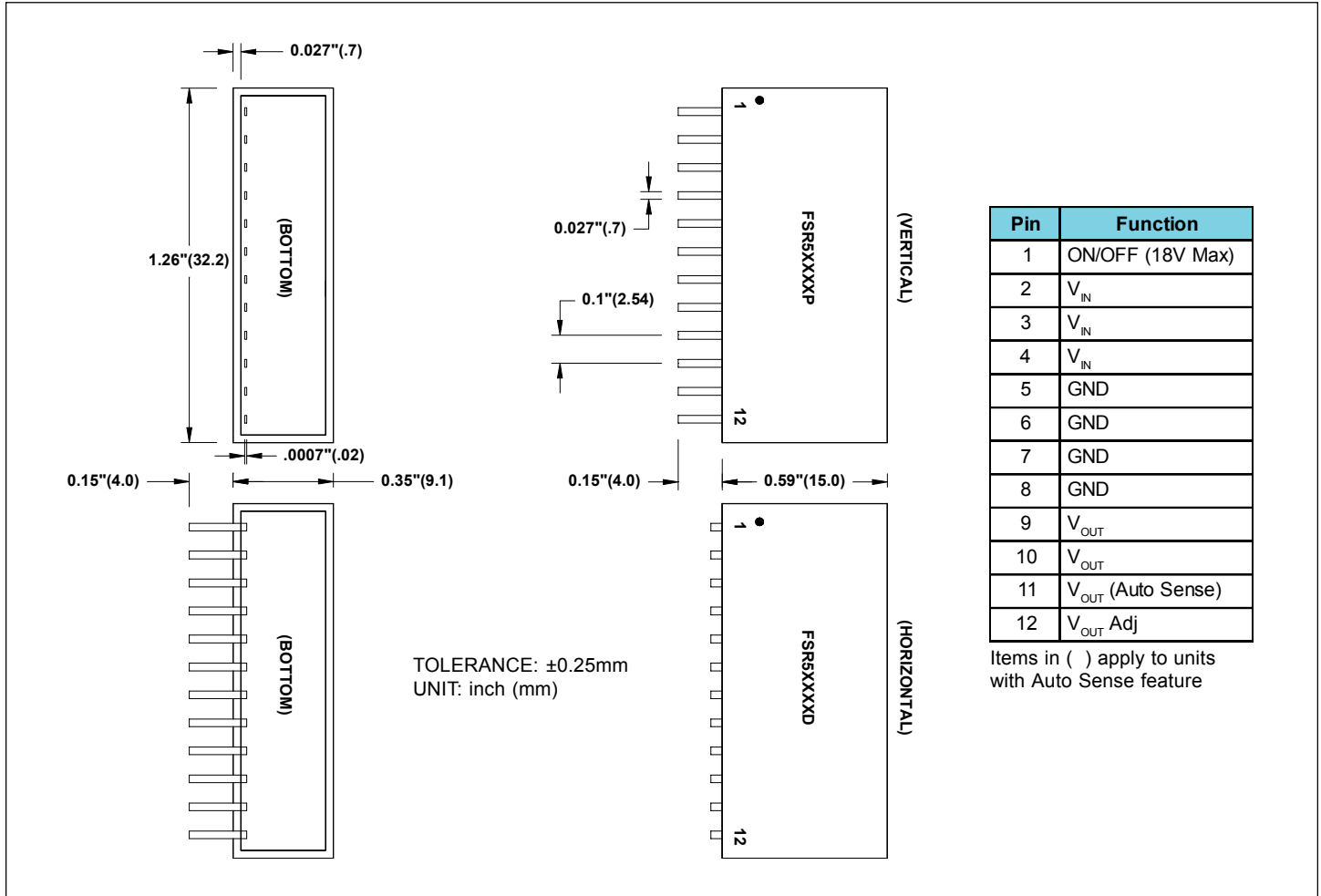

TABLE 1. Adjust output voltage vs. R1/R2 values

2A	FSR521.2P/D		FSR521.8P/D		FSR522.5P/D		FSR523.3P/D		FSR525.0P/D	
3A	FSR531.2P/D		FSR531.8P/D		FSR532.5P/D		FSR533.3P/D		FSR535.0P/D	
4A	FSR541.2P/D		FSR541.8P/D		FSR542.5P/D		FSR543.3P/D		FSR545.0P/D	
V _{OUT} (Nom)	1.2Vdc		1.8Vdc		2.5Vdc		3.3Vdc		5.0Vdc	
V _{OUT} (Adj)	R1	R2	R1	R2	R1	R2	R1	R2	R1	R2
0.8V	-	-	-	-	-	-	-	-	-	-
0.9V	740Ω	-	-	-	-	-	-	-	-	-
1.0V	3.9KΩ	-	-	-	-	-	-	-	-	-
1.1V	13KΩ	-	1.05KΩ	-	-	-	-	-	-	-
1.2V	-	-	2.1KΩ	-	270Ω	-	-	-	-	-
1.3V	-	37KΩ	3.7KΩ	-	750Ω	-	-	-	-	-
1.5V	-	11.5KΩ	10KΩ	-	2.1KΩ	-	390Ω	-	-	-
1.6V	-	8.2KΩ	18KΩ	-	3.0KΩ	-	750Ω	-	-	-
1.7V	-	6.5KΩ	41KΩ	-	4.1KΩ	-	1.2KΩ	-	-	-
1.8V	-	5.2KΩ	-	-	5.6KΩ	-	1.7KΩ	-	-	-
1.9V	-	4.3KΩ	-	36KΩ	7.5KΩ	-	2.2KΩ	-	-	-
2.0V	-	3.6KΩ	-	18KΩ	10.5KΩ	-	2.8KΩ	-	-	-
2.4V	-	2.1KΩ	-	5.2KΩ	82KΩ	-	6.8KΩ	-	-	-
2.5V	-	1.8KΩ	-	4.3KΩ	-	-	8.5KΩ	-	-	-
2.6V	-	1.65KΩ	-	3.6KΩ	-	33KΩ	10.5KΩ	-	-	-
3.0V	-	10.5KΩ	-	2.1KΩ	-	6.2KΩ	33KΩ	-	470Ω	-
3.2V	-	-	-	1.65KΩ	-	4.1KΩ	110KΩ	-	1.6KΩ	-
3.3V	-	-	-	1.5KΩ	-	3.4KΩ	-	-	2.2KΩ	-
3.4V	-	-	-	1.35KΩ	-	2.9KΩ	-	36KΩ	3.0KΩ	-
3.6V	-	-	-	1.07KΩ	-	2.2KΩ	-	11KΩ	4.7KΩ	-
3.9V	-	-	-	780Ω	-	1.4KΩ	-	4.7KΩ	8.5KΩ	-
4.5V	-	-	-	390Ω	-	650Ω	-	1.6KΩ	30KΩ	-
4.9V	-	-	-	-	-	350Ω	-	820Ω	220KΩ	-
5.0V	-	-	-	-	-	290Ω	-	680Ω	-	-
5.1V	-	-	-	-	-	220Ω	-	560Ω	-	28KΩ
5.5V	-	-	-	-	-	39Ω	-	190Ω	-	2.6KΩ

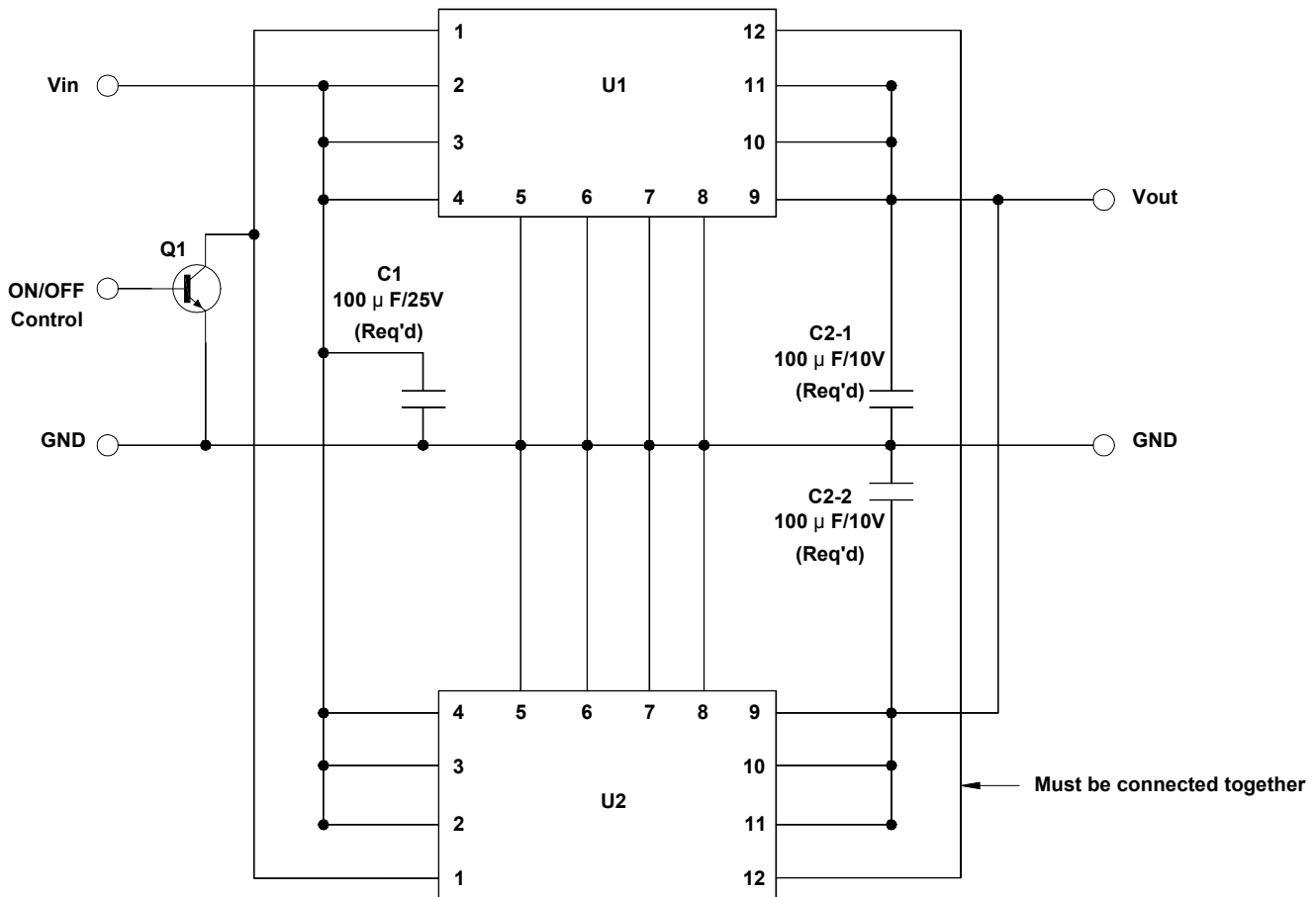
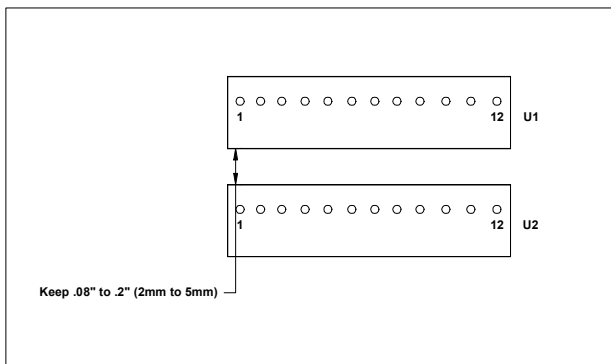
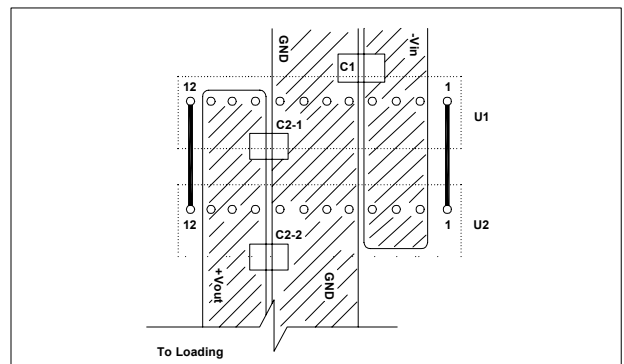

FIGURE 7. Parallel application circuit

The FSR5 series can be used in parallel applications to upgrade the output current capacity given the same output voltage value. For example, the FSR543.3P can be parallel connected with the FSR523.3P, FSR533.3P or FSR543.3P for output current up to 6, 7 or 8 amps respectively.



Component side



Solder side

FIGURE 8. Suggested PC Board layout