



5W HIGH-VOLTAGE DC/DC CONVERTER 24-PIN DIP

120, ± 120 or $240V_{OUT}$

Key Features

- Efficiency up to 93%
- 1500Vdc isolation
- Short circuit and thermal protection
- 2:1 input voltage range
- Metal case
- Six-sided shielding
- 2mA off state current
- Industry standard pinout



Beta Dyne is protected under various patents, including but not limited to U.S. Patent numbers: 5,777,519; 6,188,276; 6,262,901; 6,452,818; 6,473,3171.

Applications

- High-Voltage Power Amplifiers
- Micro-Machine Drivers
- Micro Mirrors
- Piezoelectric Transducers

Functional Description

The 5W High-Voltage DC/DC Converter 24-Pin DIP series offers a wide input voltage range with nominal inputs of 24, 48 and $120V_{IN}$. Outputs can be single, dual or dual isolated. Additional features include total input-to-output isolation, short circuit protection, thermal protection, soft start, adjustable outputs, and efficiency up to 93%.

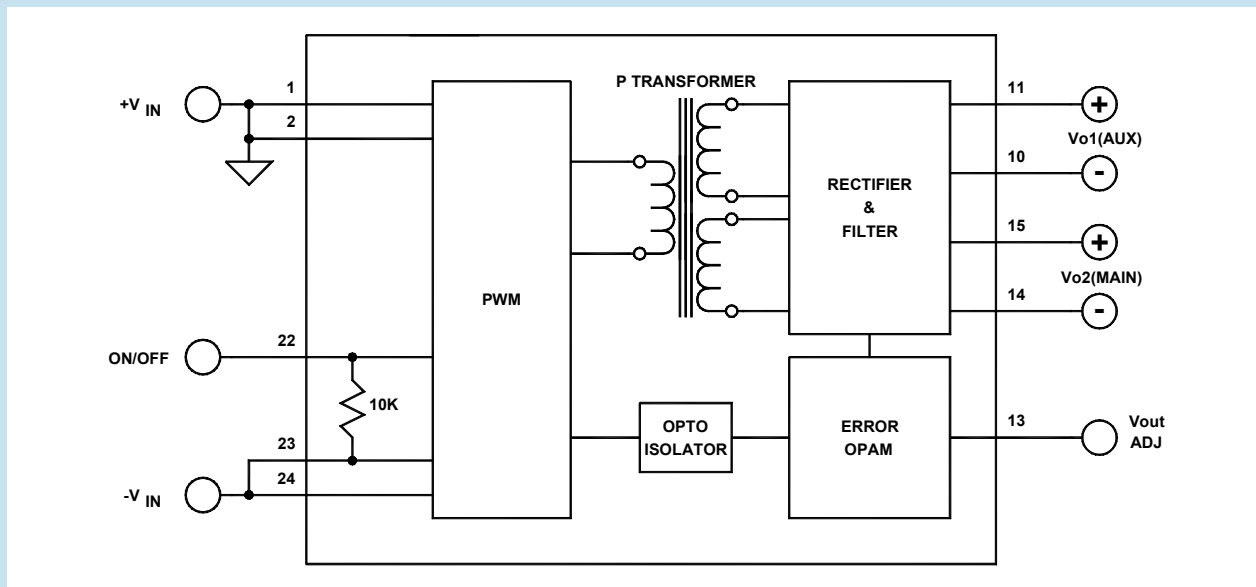

Typical Block Diagram

Electrical Specifications

ABSOLUTE MAXIMUM RATINGS

Unless otherwise specified, all parameters are given under typical +25°C with nominal input voltage and under full output load conditions.

PARAMETER	CONDITION / NOTE	MIN	TYP	MAX	UNIT
Input Voltage	See Model Selection Guide				
Output Short Circuit Duration	Continuous				
Internal Power Dissipation				1.2	W

INPUT SPECIFICATIONS

PARAMETER	CONDITION / NOTE	MIN	TYP	MAX	UNIT
Input Voltage Range (2:1)	See Model Selection Guide				
No Load Input Current	See Model Selection Guide				
Full Load Input Current	See Model Selection Guide				
Input Filter	C = 3.3 for 24V _{IN} , 2.2 for 48V _{IN} , 0.47 for 120V _{IN}				μF
Reverse Polarity	External series-blocking diode				
Reflected Ripple	I _o = FL, C _{IN} = 10μF, See appropriate connection diagram				
Input Surge Current (20μS Spike)				10	A
Short Circuit Current Limit	See Short Circuit Protection		150		% I _{IN}
Off State Current			2		mA
Remote ON/OFF Control					
Supply ON	Pin 22 Open (Open circuit voltage: 0V)				
Supply OFF	Pin 22	5	10	15	Vdc
Logic Input Reference	-Input for ON/OFF				

OUTPUT SPECIFICATIONS

PARAMETER	CONDITION / NOTE	MIN	TYP	MAX	UNIT
Output Voltage Accuracy			±1	±2	%
Ripple & Noise	With specified minimum output capacities		1	2	%V _{PP} of V _{OUT}
Output Current	See Model Selection Guide				
Line Regulation, Single and Dual			±1	±2	%
Line Regulation, Dual Isolated (AUX)	See Single for V _{o2}		±3	±5	%
Load Regulation, Single			±1	±2	%
Load Regulation, Dual	With balanced loads		±1	±2	%
Dual Isolated Output (AUX)	Output fully loaded, See Figure 5; See Single for V _{o2}		±3	±5	%
Temperature Coefficient @ FL			0.02		%/°C
Transient Response Time	50% FL to FL to 50% FL, C _o =3.3μF, See Figure 2		1	2	mS
Short Circuit Protection ¹	By input current limiting				
Output Adjust Range	See Figures 4, 5 and 6; (See App. Note DC-010)	±5		±10	%

GENERAL SPECIFICATIONS

PARAMETER	CONDITION / NOTE	MIN	TYP	MAX	UNIT
Efficiency	See Model Selection Guide				
Isolation Voltage (1 min.), Input to Output			1500		Vdc
Isolation Voltage (1 min.), Output to Output			500		Vdc
Isolation Resistance			10 ⁹		Ω
Isolation Capacitance			1000		pF
Switching Frequency			125		kHz
Turn On Delay	See Figure 2		5	10	mS
Soft Start Time	See Figure 2		20		mS

PHYSICAL CHARACTERISTICS

PARAMETER	CONDITION / NOTE	MIN	TYP	MAX	UNIT
Dimensions (L×W×H)	1.25×0.80×0.40 in. (31.75×20.32×10.16mm)				
Weight	0.56 oz. (15.8g)				
Case Material	Coated metal				
Shielding	Six-sided continuous				
Case Connection	Case and header connected to Pin 3, Floating				

ENVIRONMENTAL SPECIFICATIONS

PARAMETER	CONDITION / NOTE	MIN	TYP	MAX	UNIT
Operating Temperature Range (Ambient), 24V _N	See Figure 1	-40		+60	°C
Operating Temperature Range (Ambient), 48 & 120V _N models	See Figure 1	-40		+70	°C
Storage Temperature Range		-60		+105	°C
Thermal Shutdown	Case temperature (Input power must be recycled)	96	100	104	°C
Thermal Resistance ²	Maximum case temperature is 36°C above ambient		36	43	°C/W
Derating	See Figure 1				
Humidity	Up to 95% non-condensing				
Cooling	Free-air convection				
MTBF	per MIL-HNBK-217F (Ground benign, +25°C)		1.3x10 ⁶		hours

Model Selection Guide

MODEL NUMBER	INPUT				Reflected Ripple ⁴ (mA _{pp})	OUTPUT		
	Voltage (Vdc)		Current (mA)			Voltage (Vdc)	Current (mA)	Efficiency Full Load (%)
	Nominal	Range	No Load	Full Load ³				
5S120/24D	24	18–36	20	235	40	120	38	81
5S120/48D	48	36–72	10	120	20	120	42	87
5S120/120D	120	75–142	5	45	20	120	42	93
5D120/24D *	24	18–36	20	235	40	±120	±19	81
5D120/48D *	48	36–72	10	120	20	±120	±21	87
5D120/120D *	120	75–142	5	45	20	±120	±21	93
<i>Contact factory for custom input and output voltage combinations</i>								

* For dual independent outputs, insert an **I** after the last digit (see Ordering Guide).

¹ Input power may need to be recycled if the input overcurrent threshold is exceeded after a hard output short circuit.

² Maximum thermal resistance is given for 24V_{IN} models.

³ The maximum input current at any given input range measured at minimum input voltage is given as 1.6*I_{NOMINAL}. Nominal input current is the typical value measured at the input of the converter under full-load room temperature and nominal input voltage (24, 48 and 120Vdc).

⁴ With a 10μH input inductor and 10μF input capacitor.

ORDERING GUIDE

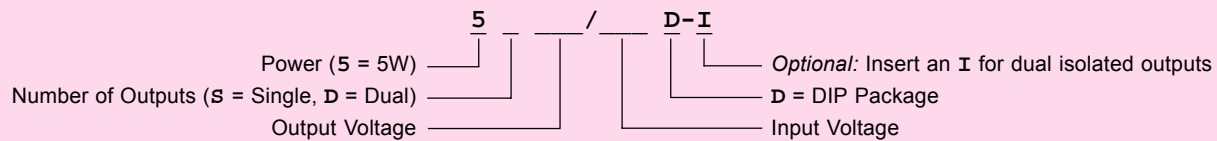

MECHANICAL SPECIFICATIONS

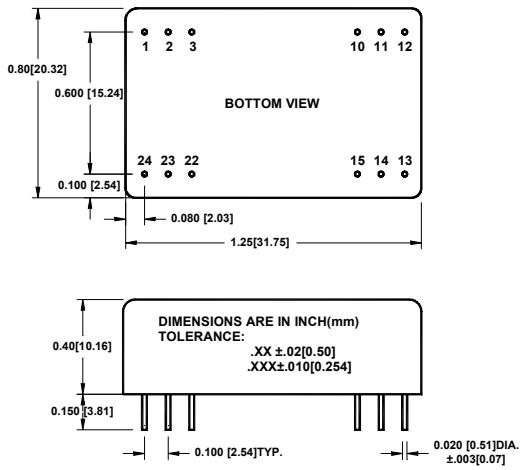

Pin	Function		
	SINGLE	DUAL	DUAL ISOLATED
1	+V _{IN}	+V _{IN}	+V _{IN}
2	+V _{IN}	+V _{IN}	+V _{IN}
3	CASE	CASE	CASE
10	-V _{O1} (CONNECT TO PIN 14)	GND (OUTPUT)	-V _{O1} (AUX)
11	+V _{O1} (CONNECT TO PIN 15)	+V _{OUT}	+V _{O1} (AUX)
12	No Pin	No Pin	No Pin
13	V _{OUT} ADJ	V _{OUT} ADJ	V _{OUT} ADJ
14	-V _{O2} (CONNECT TO PIN 10)	-V _{OUT}	-V _{O2} (MAIN)
15	+V _{O2} (CONNECT TO PIN 11)	GND (OUTPUT)	+V _{O2} (MAIN)
22	ON/OFF	ON/OFF	ON/OFF
23	-V _{IN}	-V _{IN}	-V _{IN}
24	-V _{IN}	-V _{IN}	-V _{IN}

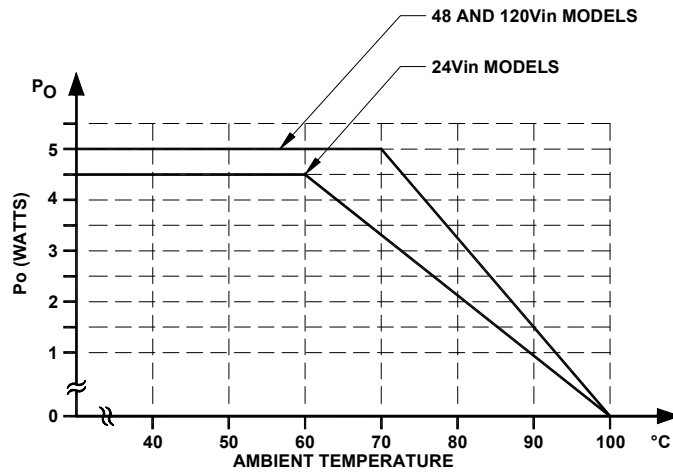

FIGURE 1. Typical derating curves of 5W DIP series

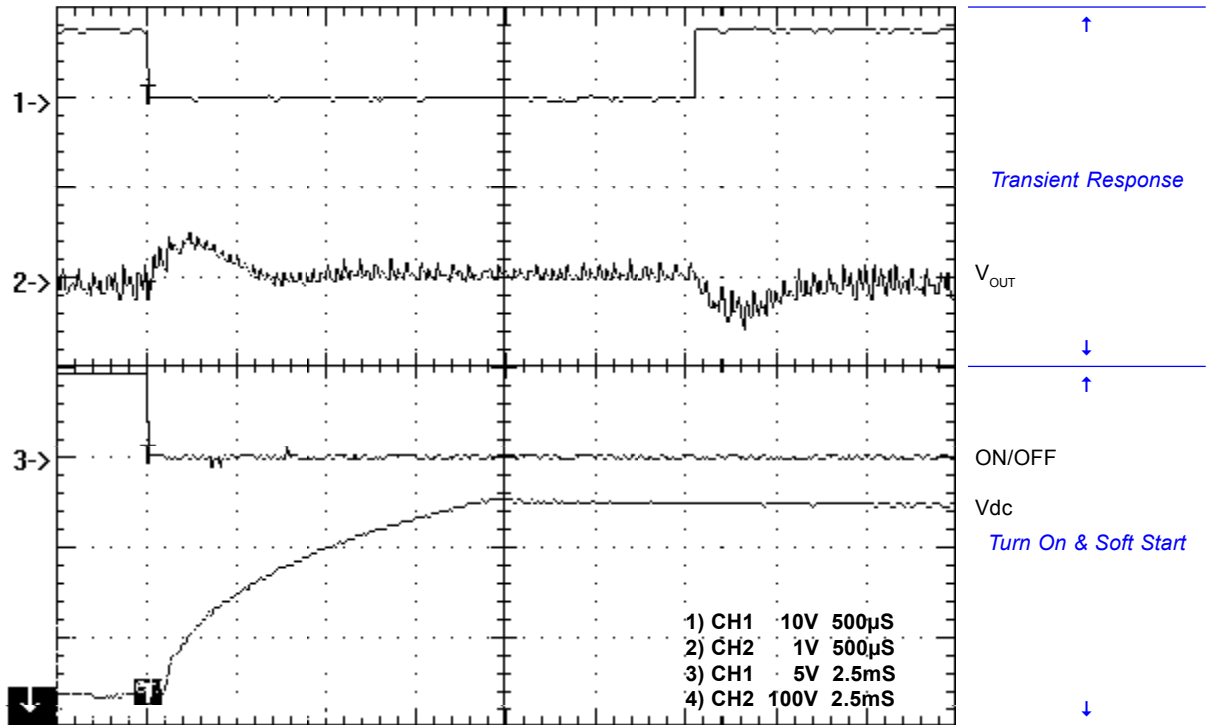

FIGURE 2. Transient Response and Soft Start of 5D240/120D
 ($R_L=10k$, $C_o=3.3\mu F@400V$)

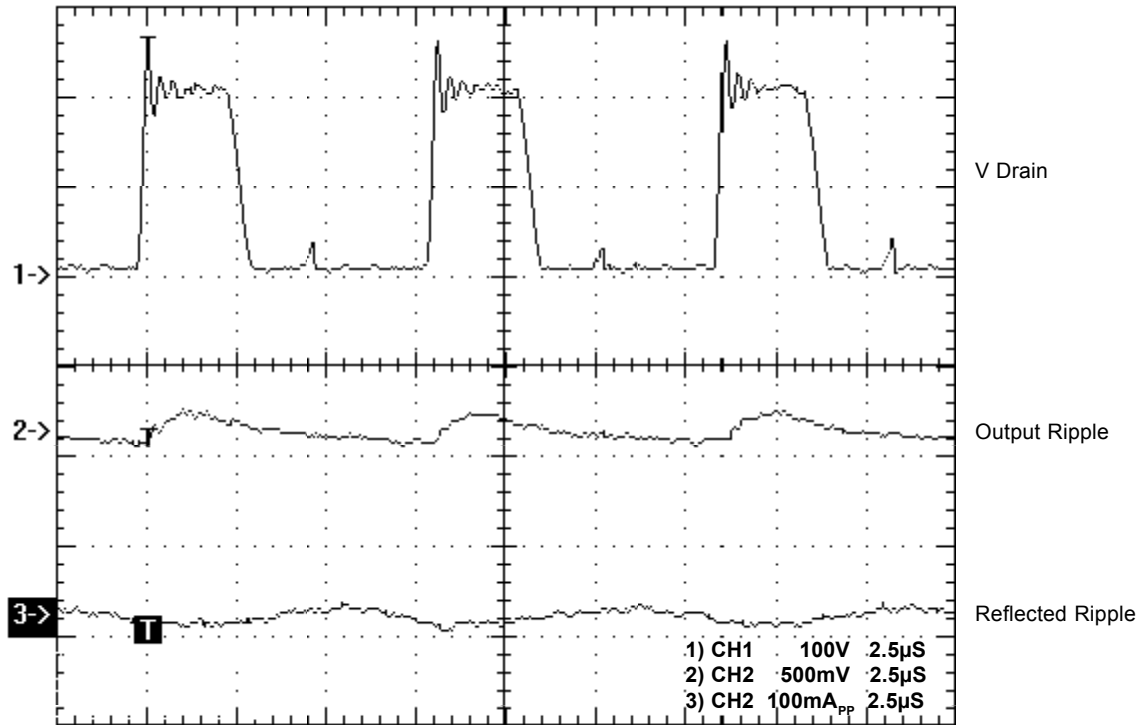

FIGURE 3. Typical waveforms of 5D120/120D
 ($R_L=20k$, $C_o=3.3\mu F@400V$)

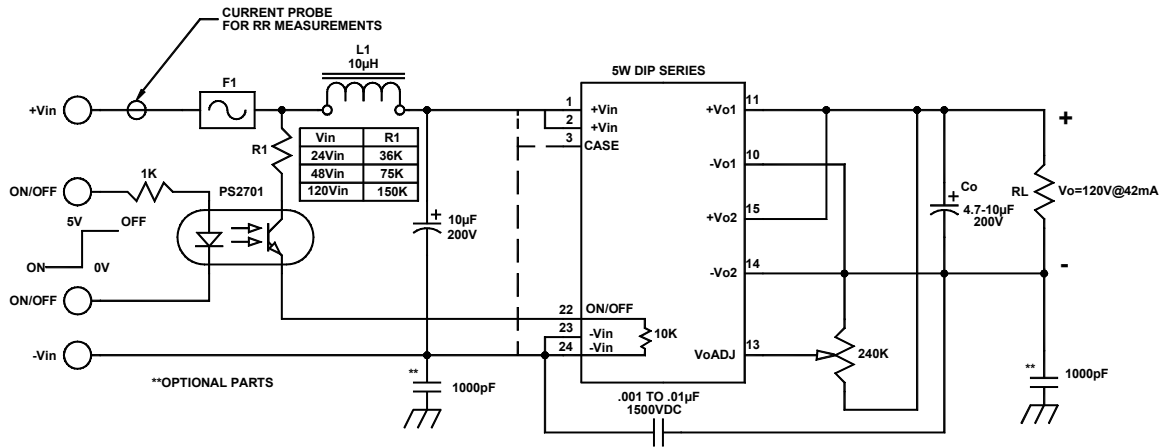

FIGURE 4. Typical connection diagram of 5W DIP Single

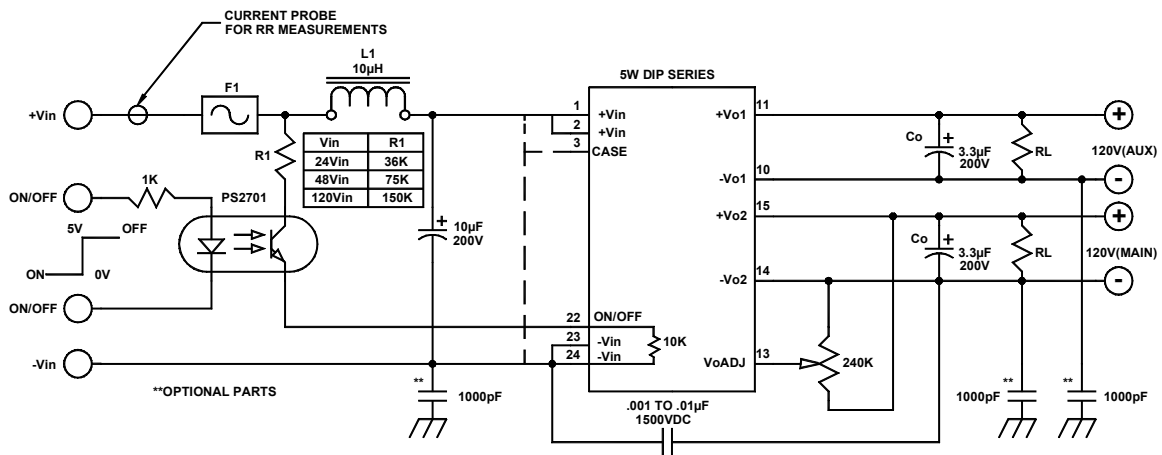

FIGURE 5. Typical connection diagram of 5W DIP Dual Isolated

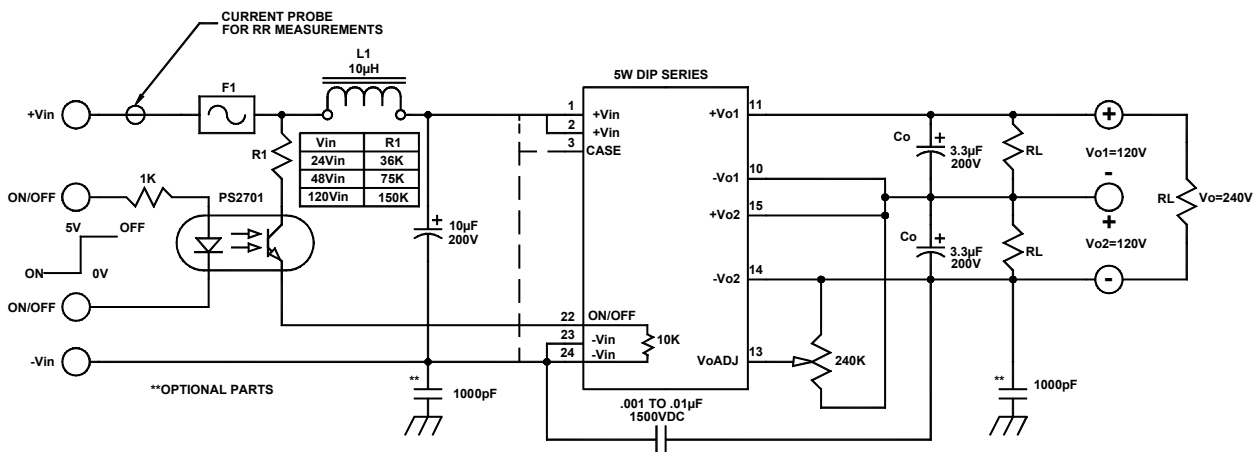

FIGURE 6. Typical connection diagram of 5W DIP Dual (240V)