



Low-Noise 15W DC/DC CONVERTER

Low Noise, High Efficiency

US Patent 5,777,519

Key Features

- Less than 5mV output noise
- Efficiency up to 88%
- Wide input voltage range (2:1)
- Six-sided shielding
- Soft start
- Single/Dual
- Short circuit and thermal protection
- Adjustable output
- 750µA off state current
- 250mV dropout linear regulators
- Dual output tracking linear regulator
- Choice of three industry pinouts
- 1.8, 2.5, 3.3V_{OUT} available upon request

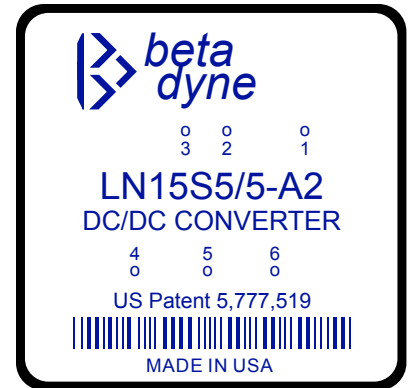
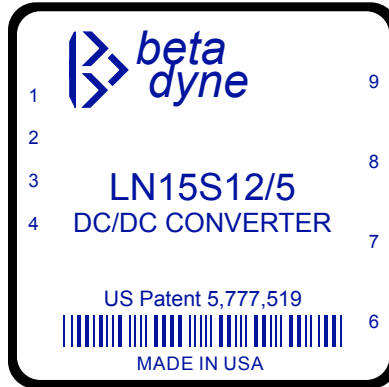

Beta Dyne is protected under various patents, including but not limited to U.S. Patent numbers: 5,777,519; 6,188,276; 6,262,901; 6,452,818; 6,473,3171.

Applications

- High-Resolution Data Converters
- Instrumentation
- Test & Measurement
- Telecom

Functional Description

The Low-Noise 15W series is a family of high-performance, low-noise isolated DC/DC converters consisting of single and dual output models with three pinouts to choose from. The converters incorporate low-switching noise techniques at their input and output sections. Low dropout linear regulators reduce the output noise to 5mV_{pp}, while a patented control circuit maintains minimum constant dropout voltage over line & load temperature and output adjust range.

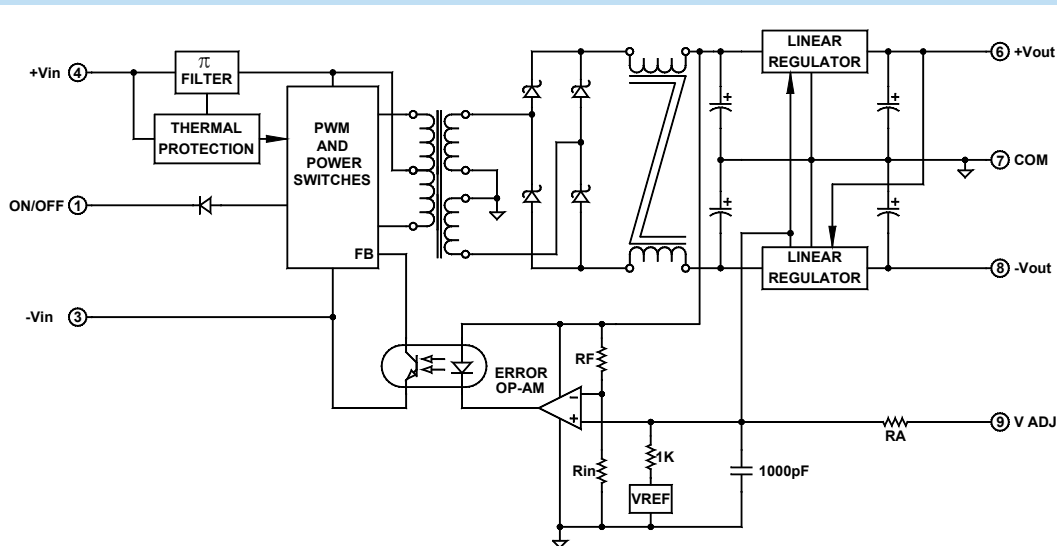

Typical Block Diagram of LN15W Bipolar Converter

Electrical Specifications

INPUT SPECIFICATIONS

Unless otherwise specified, all parameters are given under typical +25°C with nominal input voltage and under full output load conditions.

PARAMETER	CONDITION / NOTE	MIN	TYP	MAX	UNIT
Input Voltage Range	See Model Selection Guide				
Input Filter					
Reverse Polarity Input Current	External series-blocking diode			12	A
Input Surge Current (20 μ S Spike)				10	A
Short Circuit Current Limit			150		% I _{IN}
Undervoltage Shutdown			8		Vdc
Off State Current, 5V			3		mA
Off State Current, 12, 24, 48V			750		μ A
Remote ON/OFF Control					
Converter ON	Open (Open circuit voltage at Pin 1: 10V Max.)				
Converter OFF		-0.6	0	0.2	Vdc
Logic Input Reference	-Input				
Logic Compatibility	TTL Open Collector or CMOS Open Drain				

OUTPUT SPECIFICATIONS

PARAMETER	CONDITION / NOTE	MIN	TYP	MAX	UNIT
Voltage and Current Ratings	See Model Selection Guide				
Output Voltage Accuracy, Single and Dual			± 1	± 1.5	%
Output Voltage Adjustment	Standard case: Single and Dual; A1/A2 case: Single only		3	± 5	%
Voltage Balance, Dual	Balanced loads		± 0.5	± 1	%
Minimum Load ¹		10			% of FL
Ripple & Noise			5	10	mV _{PP}
Line Regulation, Single and Dual	Minimum V _{IN} to maximum V _{IN}		0.05	0.1	%
Load Regulation, Single	NL to FL		0.05	0.1	%
Load Regulation, Dual ²			± 1		%
Temperature Coefficient @ FL			0.02		%/°C
Transient Response Time (to within 0.5% of V _{OUT})	50% FL to FL to 50% FL, See Figure 1		5		μ S
Short Circuit Protection	All outputs, by input current limiting				
Output Short Circuit Duration	Continuous				

GENERAL SPECIFICATIONS

PARAMETER	CONDITION / NOTE	MIN	TYP	MAX	UNIT
Efficiency	See Model Selection Guide				
Isolation Voltage (1 min.)			1500		Vdc
Isolation Resistance			10 ⁹		Ω
Isolation Capacitance			80		pF
Switching Frequency			100		kHz

PHYSICAL CHARACTERISTICS

PARAMETER	CONDITION / NOTE	MIN	TYP	MAX	UNIT
Dimensions (L×W×H)	2.00×2.00×0.395 in. (50.80×50.80×10.03mm)				
Weight	2 oz. (58g)				
Case Material	Coated metal				
Shielding Connection, 5, 12, 24V _{IN}	-Input (Pin 3)				
Shielding Connection, 48V _{IN}	+Input (Pin 4)				

ENVIRONMENTAL SPECIFICATIONS

PARAMETER	CONDITION / NOTE	MIN	TYP	MAX	UNIT
Operating Temperature, Industrial (Ambient)*	See Figure 2	-40		+75	°C
Operating Temperature, Extended (X)	See Ordering Guide (Please contact factory)	-55		+85	°C
Storage Temperature Range		-55		+125	°C
Thermal Resistance			3.5	4	°C/W _{DISS}
Maximum Operating Case Temperature				105	°C
Thermal Turn Off, Case Temperature		95	100	115	°C
Thermal Hysterisis			20		°C
Derating	See Figure 2				
Humidity	Up to 95% non-condensing				
Cooling	Free-air convection				
EMI/RFI	Six-sided continuous shielded metal case				
MTBF	per MIL-HNBK-217F (Ground benign, +25°C)		625,000		hours

* See footnotes 3, 4, 5 and 6

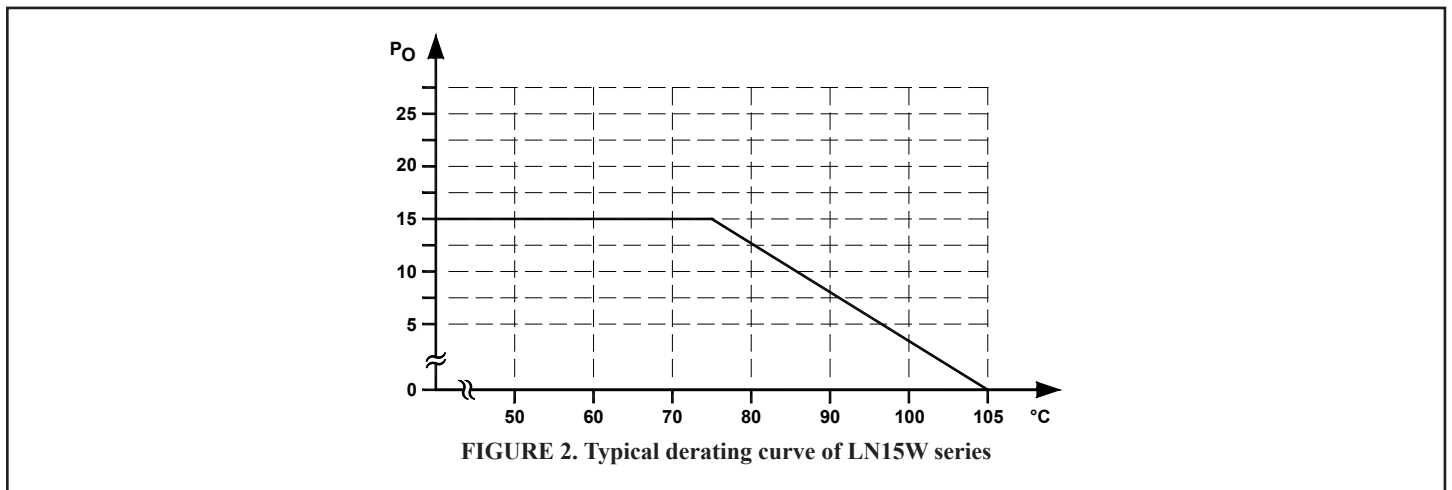
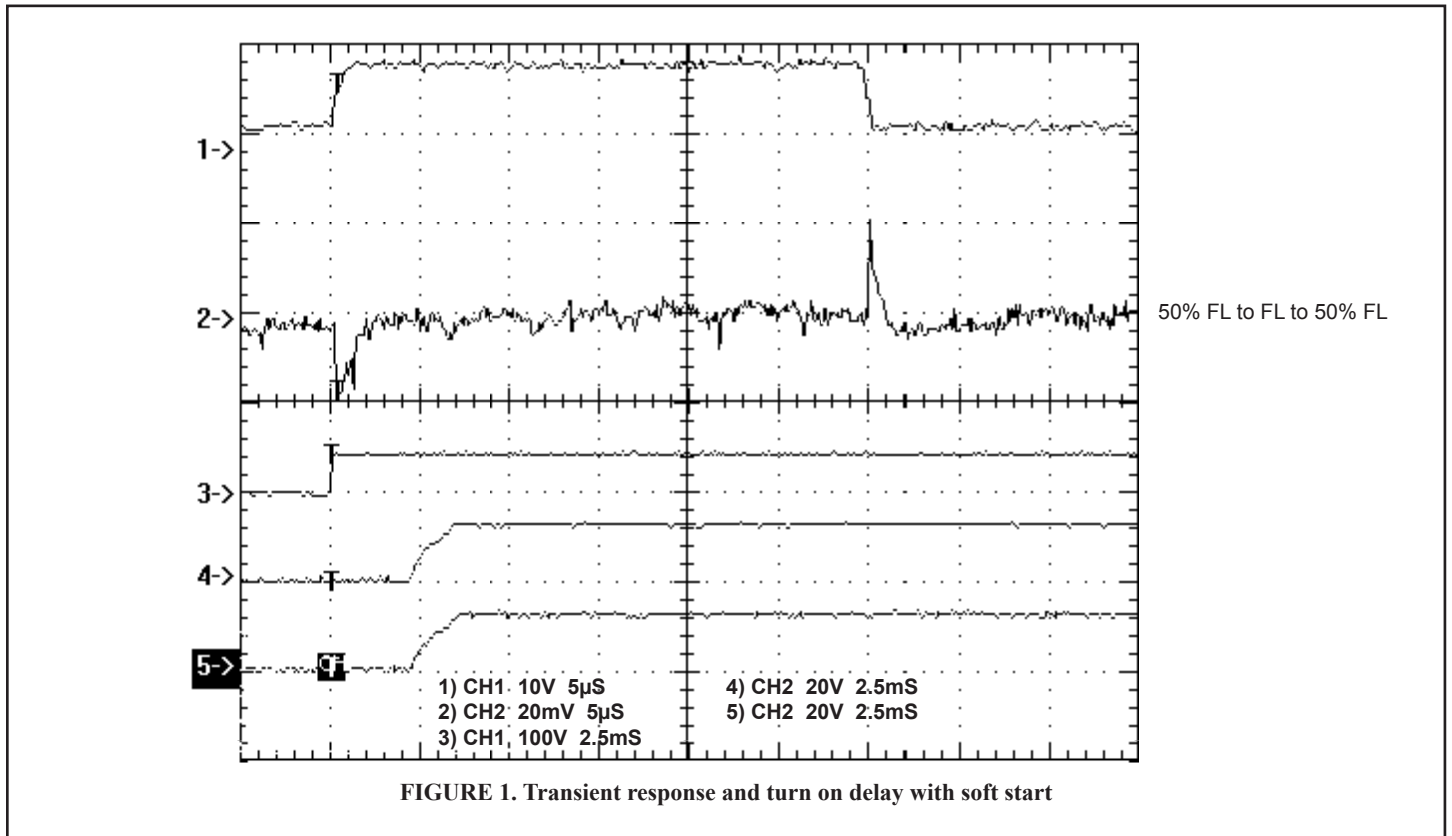

Model Selection Guide

MODEL NUMBER	INPUT				Reflected Ripple ⁷ (mA _{PP})	OUTPUT		
	Voltage (Vdc)		Current (mA)			Voltage (Vdc)	Current (mA)	Efficiency Full Load (%)
	Nominal	Range	No Load	Full Load				
LN15S5/5	5	4.75-9	40	3797	40	5	3000	79
LN15S12/5	5	4.75-9	50	3571	40	12	1250	84
LN15S15/5	5	4.75-9	70	3540	40	15	1000	85
LN15S5/12	12	9.5-18	20	1582	40	5	3000	79
LN15S6/12	12	9.5-12	22	1520	40	6	2500	82
LN15S12/12	12	9.5-18	30	1510	40	12	1250	83
LN15S15/12	12	9.5-18	30	1471	40	15	1000	85
LN15S3.3/24	24	18-36	15	822	35	3.3	4545	76
LN15S5/24	24	18-36	10	762	30	5	3000	82
LN15S12/24	24	18-36	10	720	30	12	1250	87
LN15S15/24	24	18-36	10	710	30	15	1000	88
LN15S3.3/48	48	36-72	10	409	20	3.3	4540	76
LN15S5/48	48	36-72	10	385	20	5	3000	81
LN15S12/48	48	36-72	10	360	20	12	1250	88
LN15S15/48	48	36-72	10	360	20	15	1000	88
LN15D5/5	5	4.75-9	70	3797	40	±5	±1500	79
LN15D12/5	5	4.75-9	70	3704	40	±12	±625	81
LN15D15/5	5	4.75-9	70	3750	40	±15	±500	80
LN15D5/12	12	9-18	30	1582	40	±5	±1500	79
LN15D12/12	12	9-18	30	1524	40	±12	±625	82
LN15D15/12	12	9-18	30	1524	40	±15	±500	82
LN15D5/24	24	18-36	10	770	30	±5	±1500	81
LN15D12/24	24	18-36	10	762	30	±12	±625	82
LN15D15/24	24	18-36	10	750	30	±15	±500	83
LN15D5/48	48	36-72	10	390	20	±5	±1500	80
LN15D12/48	48	36-72	10	376	20	±12	±625	83
LN15D15/48	48	36-72	10	370	20	±15	±500	84

Contact factory for custom input and output voltage combinations

- ¹ In applications where the -V_{OUT} is loaded more than +V_{OUT}, a minimum load is required between +V_{OUT} and GND. If the load is connected between +V_{OUT} and -V_{OUT}, no minimum load is required.
- ² For dual converters if only the -V_{OUT} is loaded. A 10% FL must be connected from +V_{OUT} to Ground.
- ³ Contact factory for -55° to +85°C operating temperature range.
- ⁴ The maximum input current at any given input range measured at minimum input voltage is given as 1.6*I_{NOMINAL}. Nominal input current is the typical value measured at the input of the converter under full-load room temperature and nominal input voltage (5, 12, 24 and 48V_{IN}).
- ⁵ Adequate insulation is to be provided to the converters at the end usage as per applicable requirements.
- ⁶ Temperature rise on the case of the converters is to be considered during the end usage as per applicable requirements.
- ⁷ Measured with 100µF external capacitor at the input pins.

ORDERING GUIDE

LN15 / X-

<p>Power <input type="text"/></p> <p>Number of Outputs (S = Single, D = Dual) <input type="text"/></p> <p>Output Voltage <input type="text"/></p>	<p>Case Type:</p> <p>Leave blank for standard case</p> <p>Insert A1 for 2:3 pin case without ON/OFF pin</p> <p>Insert A2 for 3:3 pin case with ON/OFF pin</p> <p>Insert X for -55°C to +85°C (Optional)</p> <p>Input Voltage <input type="text"/></p>
---	--

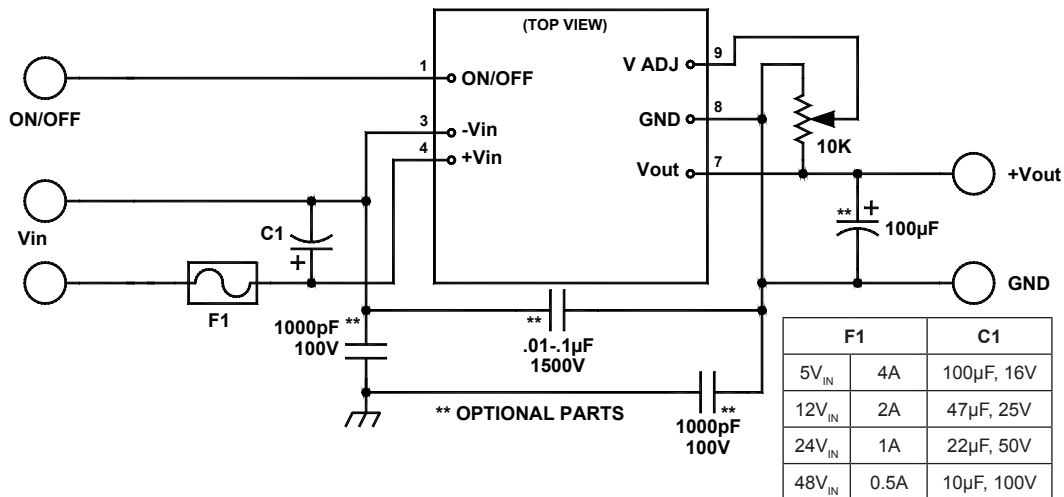
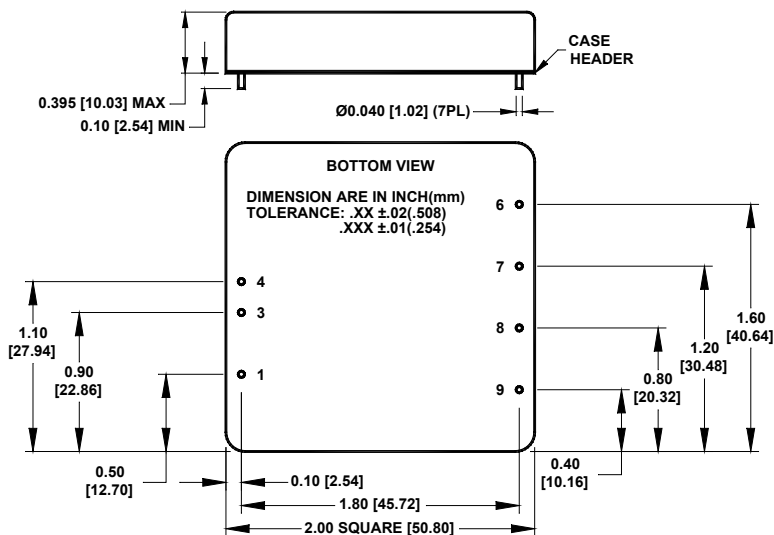

FIGURE 3. Typical connection diagram of LN15W Single DC/DC Converter

MECHANICAL SPECIFICATIONS STANDARD CASE



STANDARD CASE

Pin	Function	
	SINGLE	DUAL
1	ON/OFF	ON/OFF
2	No Pin	No Pin
3	-V _{IN}	-V _{IN}
4	+V _{IN}	+V _{IN}
5	No Pin	No Pin
6	No Pin	+V _{OUT}
7	+V _{OUT}	GND
8	-V _{OUT}	-V _{OUT}
9	V _{ADJ}	V _{ADJ}

A1/A2 CASE

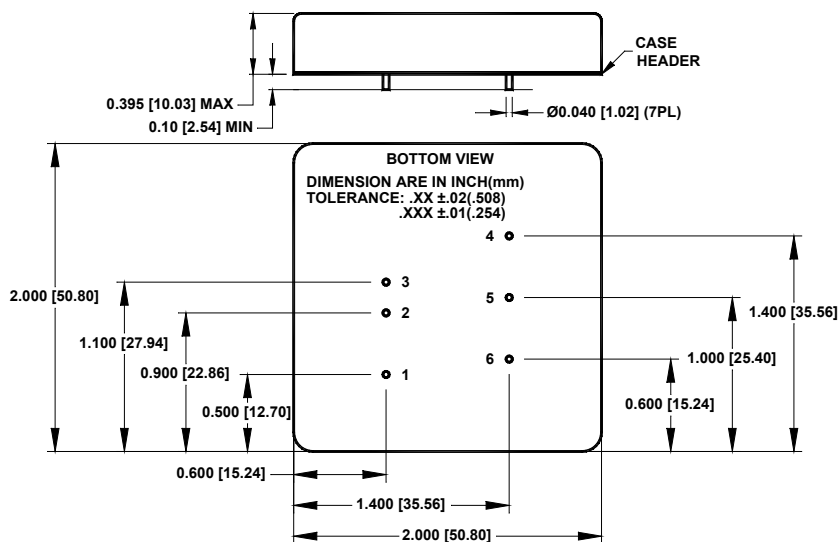

A1/A2 CASE

Pin	Function	
	SINGLE	DUAL
1	ON/OFF* (Optional)	ON/OFF* (Optional)
2	-V _{IN}	-V _{IN}
3	+V _{IN}	+V _{IN}
4	+V _{OUT}	+V _{OUT}
5	TRIM	COMMON
6	-V _{OUT}	-V _{OUT}

* See Ordering Guide

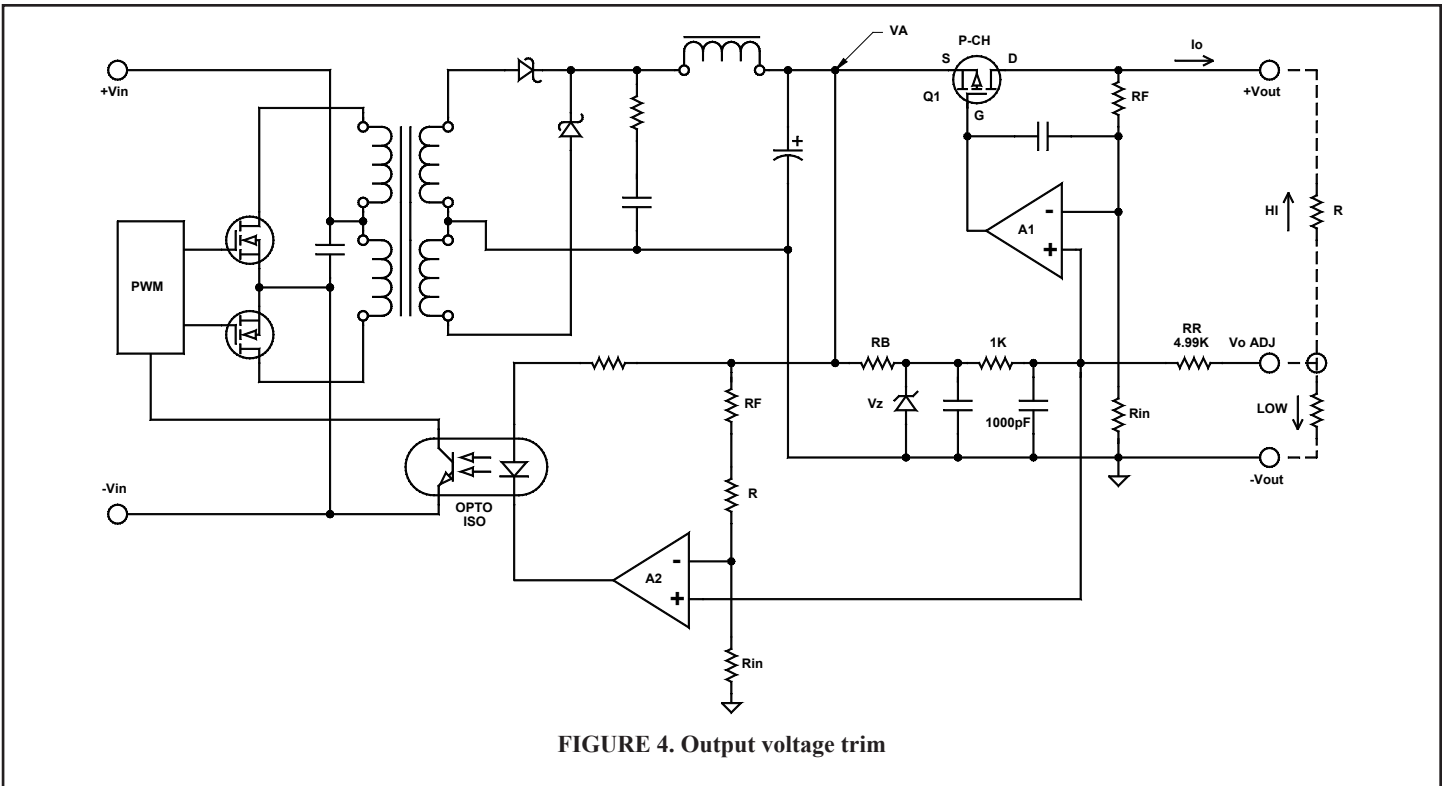

FIGURE 4. Output voltage trim

OUTPUT VOLTAGE TRIM

The LN series features a unique output control circuit that maintains constant the drop out voltage of its linear regulator in order to minimize internal power dissipation and to maximize the efficiency of the converter. The same voltage reference is driving both the linear regulator and the error amplifier of the converter. The voltage reference is referenced to the output ground for the single and dual converters, and the positive input of both error amplifiers of the linear regulator and converter are adjusted through the V_o Adjust pin.

As shown in Figure 4, the positive input of the error amplifier is biased through 1kΩ 1% resistors from the voltage reference. When the output is adjusted (trimmed), a voltage divider is formed by the 1K and RA. To trim the output high, the resistor calculated from the formula below is inserted between the +V_{OUT} and V_o Adjust pins. To trim the output low, the selected resistor is placed between the Ground and V_o Adjust pins.

$$R \text{ Trim (in k}\Omega) \text{ HI} = \frac{1-\alpha}{\frac{\alpha \cdot V_{REF}}{V_{OH}} - 1} - 4.99$$

$$R \text{ Trim (in k}\Omega) \text{ LOW} = \frac{1}{\frac{\alpha \cdot V_{REF}}{V_{OL}} - 1} - 4.99$$

where α is given in Table 1.

EXAMPLE: A single 15V_{OUT} converter needs to be set at 15.5V, calculate the needed external resistor:

From Table 1, α = 6

$$R = (-5/[(6 \cdot 2.5)/15.5] - 1) - 4.99 = 150k\Omega$$

To trim the same converter lower to 14.5V:

$$R \text{ (in k}\Omega) = (1/[(15/14.5) - 1] - 4.99 = 24k\Omega$$

TABLE 1

V _o Nominal (V)	
5, ±5	2
12, ±12	4.8
15, ±15	6