



15W DC/DC CONVERTER

Wide 3:1 Input Voltage Range
Single/Dual/Triple/Dual Positive Output

Key Features

- Wide input voltage range (3:1)
- Efficiency up to 87%
- Input-to-output isolation
- Soft start
- Short circuit protection
- 150µA off state current
- Multiple converter synchronization
- Dual isolated output
- Output overvoltage protection (OVP)



Beta Dyne is protected under various patents, including but not limited to U.S. Patent numbers: 5,777,519; 6,188,276; 6,262,901; 6,452,818; 6,473,3171.

Functional Description

The 15W series is a family of single, dual and triple output DC/DC converters that offer 3:1 input voltage range, 400kHz switching frequency, forward topology and come packaged in a 2×1×0.395-inch case with an industry standard pin out arrangement. Synchronous rectification improves the efficiency in the single models, while the dual isolated output offers design flexibility in the dual models. Six-sided shielding, SMD and improved thermal techniques guarantee reliability.

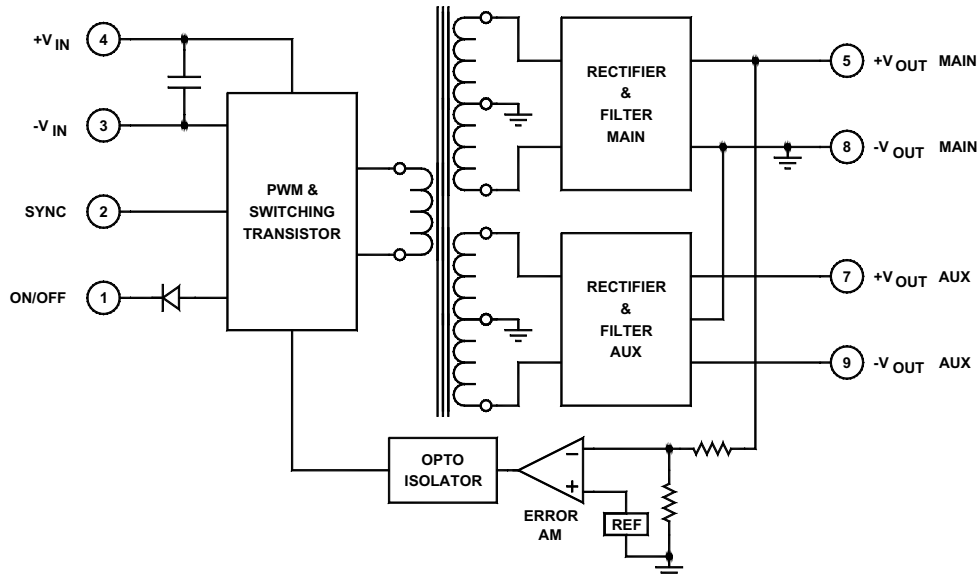

Typical Block Diagram (Triple Output)

Electrical Specifications

INPUT SPECIFICATIONS

Unless otherwise specified, all parameters are given under typical +25°C with nominal input voltage and under full output load conditions.

PARAMETER	CONDITION / NOTE	MIN	TYP	MAX	UNIT
Input Voltage Rang	See Model Selection Guide				
Input Startup Voltage, 24V _{IN}		7			Vdc
Input Startup Voltage, 48V _{IN}		12			Vdc
Undervoltage Shutdown	24V _{IN} = 6Vdc, 48V _{IN} = 11Vdc		8		Vdc
Input Filter	LC				
Reverse Polarity	External series-blocking diode				
No Load Input Current	See Model Selection Guide				
Input Surge Current (20µS Spike)				10	A
Short Circuit Current Limit			150		% I _{IN}
Off State Current			150		µA
Remote ON/OFF Control					
Supply ON	Pin 1 Open (Open circuit voltage: 12V Max.)				
Supply OFF		0		0.8	Vdc
Logic Input Reference	-Input for ON/OFF and SYNC				

OUTPUT SPECIFICATIONS

PARAMETER	CONDITION / NOTE	MIN	TYP	MAX	UNIT
Voltage and Current Ratings	See Model Selection Guide				
Output Voltage Accuracy, Single and Dual			±1		%
Output Voltage Accuracy, Triple (Main)			±1		%
Output Voltage Accuracy, Triple (Auxiliary)			3	±5	%
Output Voltage Adjustment	Single and Dual only		5		%
Voltage Balance, Dual	Balanced loads			±2	%
Voltage Balance, Triple (Auxiliary)	Balanced loads for auxiliary			±2	%
Minimum Load	0% for Single output, 10% for all other models				% of FL
Ripple & Noise			1	2	%V _{PP} of V _{OUT}
Line Regulation, Single	Minimum V _{IN} to maximum V _{IN}		±0.5	1	%
Line Regulation, Dual and Triple (Main)	Minimum V _{IN} to maximum V _{IN}		±1	2	%
Line Regulation, Triple (Main)	With balanced loads		±5	5	%
Load Regulation, Single	NL to FL		±1		%
Load Regulation, Dual *	See Figure 5 for isolated output		±1		%
Load Regulation, Triple (Main)	Main fully loaded		±1		%
Load Regulation, Triple (Auxiliary)	See Figure 6		±5		%
Temperature Coefficient @ FL			0.02		%/°C
Transient Response Time	50% FL to FL to 50% FL		100	150	µS
Short Circuit Protection	All outputs, by input current limiting				
Turn On Delay with Soft Start			2		mS
Output Overvoltage Protection			130	150	% of V _{OUT}

* Maximum output current must not exceed 2 amps at either output.

GENERAL SPECIFICATIONS

PARAMETER	CONDITION / NOTE	MIN	TYP	MAX	UNIT
Efficiency (at full power)	See Model Selection Guide				
Isolation Voltage (1 min.), Input to Output	All models		1500		Vdc
Isolation Voltage, Output to Output	Dual only		500		Vdc
Isolation Resistance			10 ⁹		Ω
Isolation Capacitance			500		pF
Switching Frequency			400		kHz

ENVIRONMENTAL SPECIFICATIONS

PARAMETER	CONDITION / NOTE	MIN	TYP	MAX	UNIT
Operating Temperature, Industrial (Ambient)	See Figure 1	-40		+71	°C
Operating Temperature, Extended		-55		+85	°C
Storage Temperature Range		-55		+125	°C
Thermal Resistance				7.4	°C/W _{DISS}
Maximum Operating Case Temperature				100	°C
Derating	See Figure 1				
Humidity	Up to 95% non-condensing				
Cooling	Free-air convectio				
EMI/RFI	Six-sided continuous shielded metal case				
MTBF	per MIL-HNBK-217F (Ground benign, +25°C)		1.1×10 ⁶		hours

PHYSICAL CHARACTERISTICS

PARAMETER	CONDITION / NOTE	MIN	TYP	MAX	UNIT
Dimensions (L×W×H)	2.00×1.00×0.395 in. (50.80×25.40×10.03mm)				
Weight	1.06 oz. (30.3g)				
Case Material	Coated metal				
Shielding Connection, 24V _{IN}	-Input Ground (Pin 3)				
Shielding Connection, 48V _{IN}	+Input (Pin 4)				

EXTERNAL SYNCHRONIZATION

The converters can be synchronized to an external TTL or CMOS clock signal. Insert a 470pF to 1000pF ceramic capacitor between the driving clock signal and the SYNC pin (Pin 2) of the converter. The frequency of the signal must be between 390kHz

and 430kHz, with a duty cycle of 50% and an amplitude between 3Vdc minimum and 5Vdc typical. See Application Note DC-005: Synchronization.

EXTERNAL TRIMMING OF OUTPUT VOLTAGES (SINGLE AND DUAL ONLY)

To trim the output voltage DOWN, connect a 1% 1/8W resistor between the + (plus) output and trim pin of the converter. To trim the output voltage UP, connect a 1% 1/8W resistor between the – (minus) output and trim pins of the converter. For UP/DOWN trimming capability, connect a 10kΩ potentiometer between the + and – output pins, with the wiper arm connected to the trim pin.

The trim resistors/potentiometer can be connected at the converter output pins or the load. However, if connected at the load,

the resistance of the runs becomes part of the feedback network which improves load regulation. If the load is some distance from the converter, the use of #20 gauge wire is recommended to avoid excessive voltage drop due to the resistance of the circuit paths.

See our application notes:

DC-001: Testing Transient Response in DC/DC Converters
DC-004: Thermal Consideration for DC/DC Converters

TABLE 1. Minimum input operating voltage range for 24V_{IN} and 48V_{IN} models

15W SINGLE

%FL	Minimum Input Operating Voltage	
	24 V _{in}	48 V _{in}
10	7.0	14.0
25	8.5	17.0
50	8.8	18.0
75	9.0	18.5
100	9.5	19.5

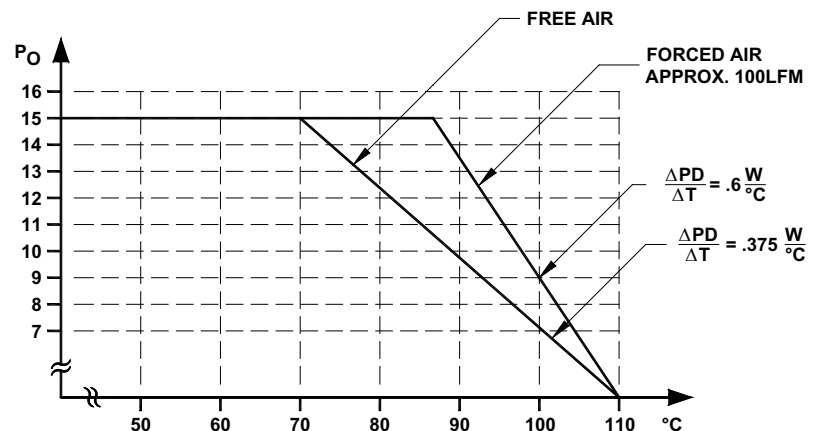

FIGURE 1. Worst case derating of 15W series

Model Selection Guide

MODEL NUMBER	INPUT				Reflected Ripple* (mA _{pp})	OUTPUT		
	Voltage (Vdc)		Current (mA)			Voltage (Vdc)	Current (mA)	Efficiency Full Load (%)
	Nominal	Range	No Load	Full Load				
15S1.8/24	24	10-30	20	500	100	1.8	5000	75
15S2.5/24	24	10-30	20	660	120	2.5	5000	79
15S3.3/24	24	10-30	20	764	120	3.3	4500	81
15S5/24	24	10-30	20	760	120	5	3000	82
15S12/24	24	10-30	10	770	120	12	1250	81
15S15/24	24	10-30	10	775	120	15	1000	80
15S20/24	24	18-36	10	780	120	20	750	80
15S1.8/48	48	20-60	20	237	90	1.8	5000	79
15S2.5/48	48	20-60	20	320	100	2.5	5000	81
15S3.3/48	48	20-60	20	410	100	3.3	5000	84
15S5/48	48	20-60	20	360	100	5	3000	87
15S12/48	48	20-60	10	380	100	12	1250	82
15S15/48	48	20-60	10	380	100	15	1000	82
15D5/24	24	10-30	20	780	120	+5/-5	±1500	80
15D12/24	24	10-30	20	780	120	+12/-12	±625	80
15D15/24	24	10-30	20	780	120	+15/-15	±500	80
15D18/24	24	10-30	20	780	150	+18/-18	±416	80
15D2.5-3.3/24-I	24	10-30	20	620	120	2.5/3.3	2000/2000	78
15D2.5-5/24-I	24	10-30	20	790	120	2.5/5	2000/2000	79
15D3.3-5/24-I	24	10-30	20	770	120	3.3/5	2000/1500	79
15D5/48	48	20-60	30	376	90	+5/-5	±1500	83
15D7/48	48	20-60	30	391	90	+7/-7	±1.07	80
15D12/48	48	20-60	30	367	90	+12/-12	±625	85
15D15/48	48	20-60	30	367	90	+15/-15	±500	85
15D2.5-3.3/48-I	48	20-60	10	300	90	2.5/3.3	2000/2000	81
15D2.5-5/48-I	48	20-60	10	385	90	2.5/5	2000/2000	80
15D3.3-5/48-I	48	20-60	10	360	90	3.3/5	2000/1500	82
15T3.3-5/24	24	10-30	10	743	120	3.3±5	2000/750	79
15T5-12/24	24	10-30	10	781	120	5±12	1500/312	80
15T5-15/24	24	10-30	10	781	120	5±15	1500/250	80
15T3.3-5/48	48	20-60	20	365	90	3.3±5	2000/750	82
15T5-12/48	48	20-60	10	370	90	5±12	1500/312	85
15T5-15/48	48	20-60	10	373	90	5±15	1500/250	84
15T5.6-15/48	48	20-60	10	390	90	5.6±15	1350/250	80

* Measured with 10µF capacitor at the input power pins

Contact factory for custom input and output voltage combinations

ORDERING GUIDE

15

Power Output (W)

Number of Outputs (S = Single, D = Dual, T = Triple)

Output Voltage

/

X-I

Insert I for dual isolated outputs (Optional)

Insert X for -55°C to +85°C (Optional)

Input Voltage

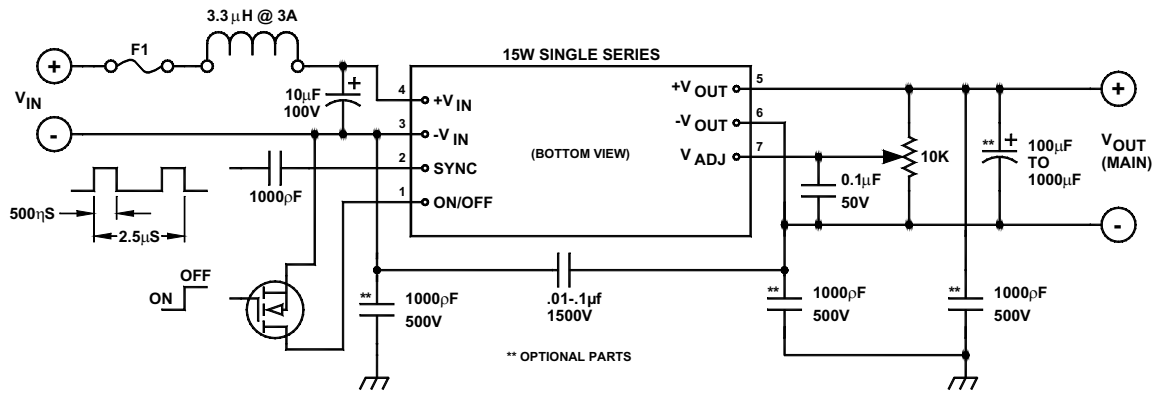

FIGURE 2. Typical connection diagram of a 15W single converter

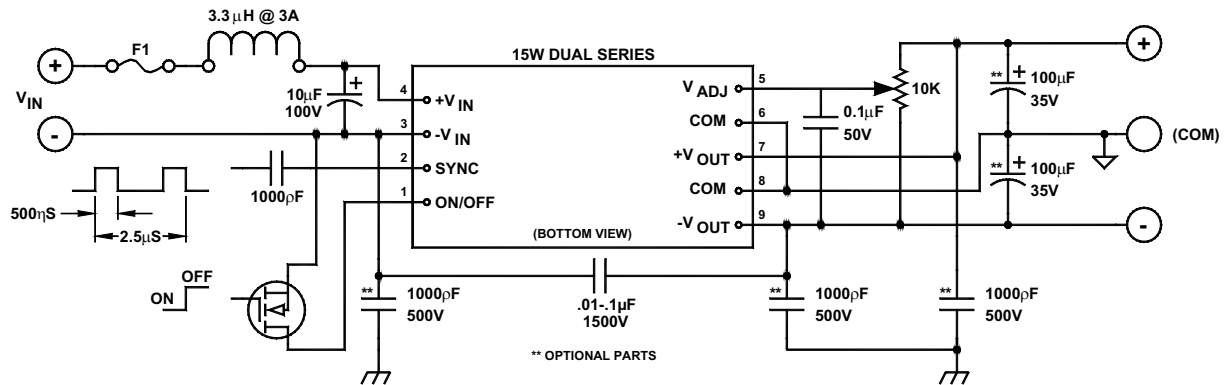

FIGURE 3. Typical connection diagram of a 15W dual converter

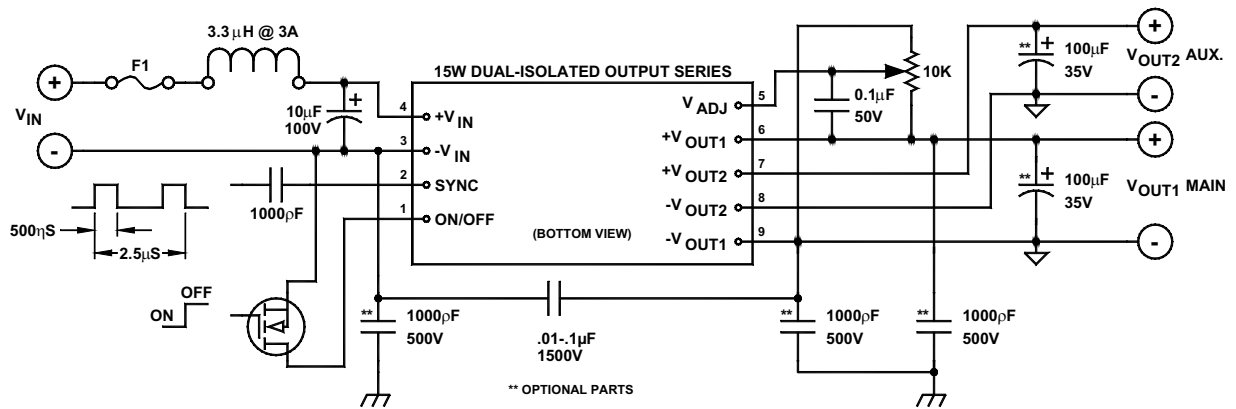

FIGURE 4. Typical connection diagram of a 15W dual isolated output converter

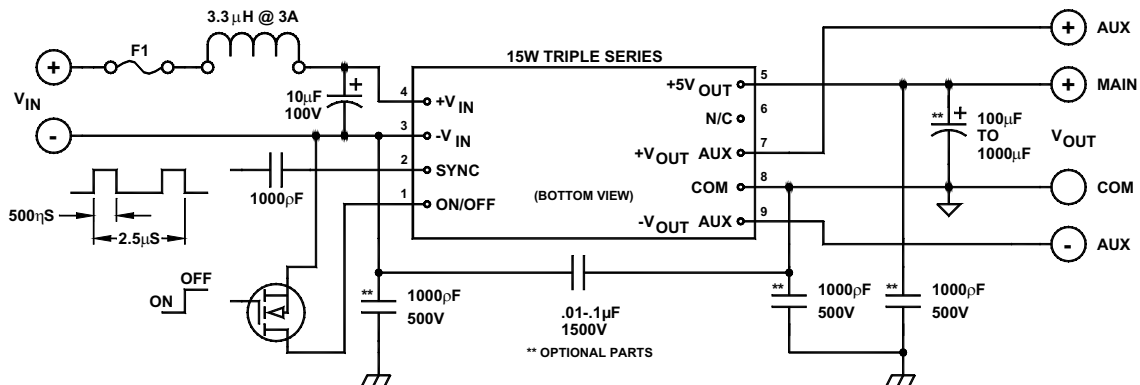
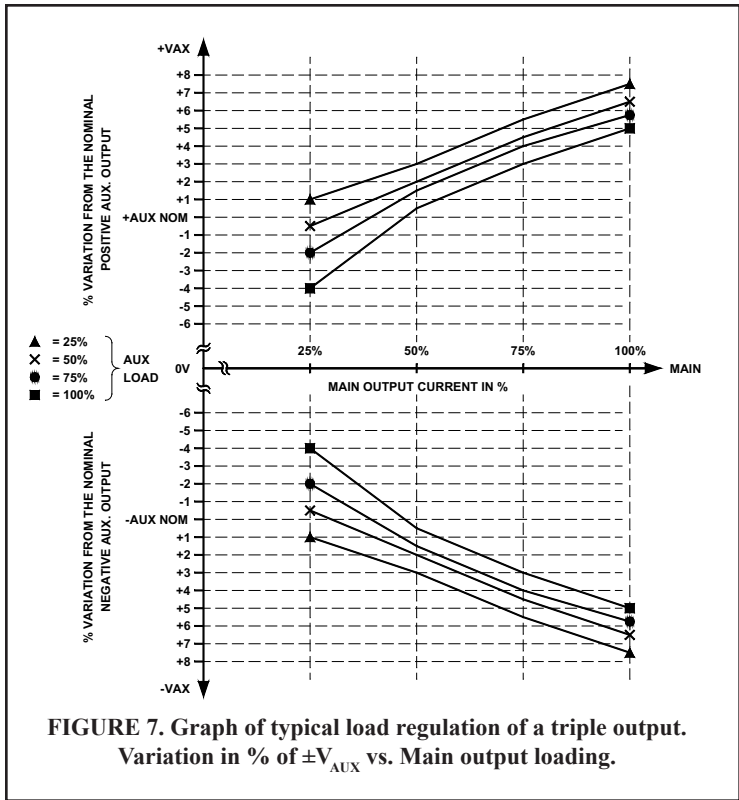
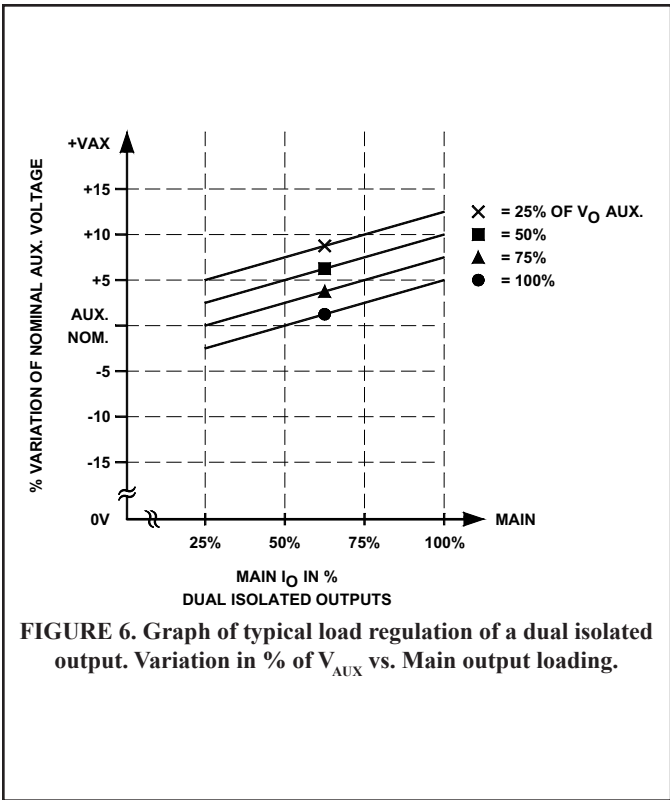

FIGURE 5. Typical connection diagram of a 15W triple converter



MECHANICAL SPECIFICATIONS

in inches [mm]

Pin	Function			
	SINGLE	DUAL	DUAL ISO-LATED	TRIPLE
1	ON/OFF	ON/OFF	ON/OFF	ON/OFF
2	SYNC	SYNC	SYNC	SYNC
3	$-V_{IN}$	$-V_{IN}$	$-V_{IN}$	$-V_{IN}$
4	$+V_{IN}$	$+V_{IN}$	$+V_{IN}$	$+V_{IN}$
5	+OUTPUT	V_{ADJ}	V_{ADJ}	$+V_{OUT}$ MAIN
6	-OUTPUT	GND	$+V_{O1}$ (MAIN)	No Pin
7	$+V_{ADJ}$	+OUTPUT	$+V_{O2}$ (AUX)	$+V_{OUT}$ AUX
8	No Pin	GND	$-V_{O2}$ (AUX)	GND
9	No Pin	-OUTPUT	$-V_{O1}$ (MAIN)	$-V_{OUT}$ AUX