

Key Features

- External frequency selection 18Hz to 80Hz
- External amplitude selection 10Vdc to 220Vdc
- Onboard sinewave programmable reference
- Remote ON/OFF control
- Wide input voltage range
- Isolated output
- Over/under input voltage protection
- Short circuit protection
- Over temperature protection
- Six-sided shielding



Beta Dyne is protected under various patents, including but not limited to U.S. Patent numbers: 5,777,519; 6,188,276; 6,262,901; 6,452,818; 6,473,3171.

Applications

- PBX, PABX, DLC and Key Systems
- POTS
- Wireless Local Loop Systems
- Short/Long Loop Applications
- Test Equipment
- Longitudinal Noise Generator

Functional Description

The RG15000 is a power-processing device based on a unique architecture suitable for multiple applications. The RG15000 can operate as a ring generator, low-frequency power amplifier, programmable AC power supply or as a high-voltage electronic load for test equipment applications. Key features include isolated output, over/under voltage protection, short circuit protection and thermal protection.

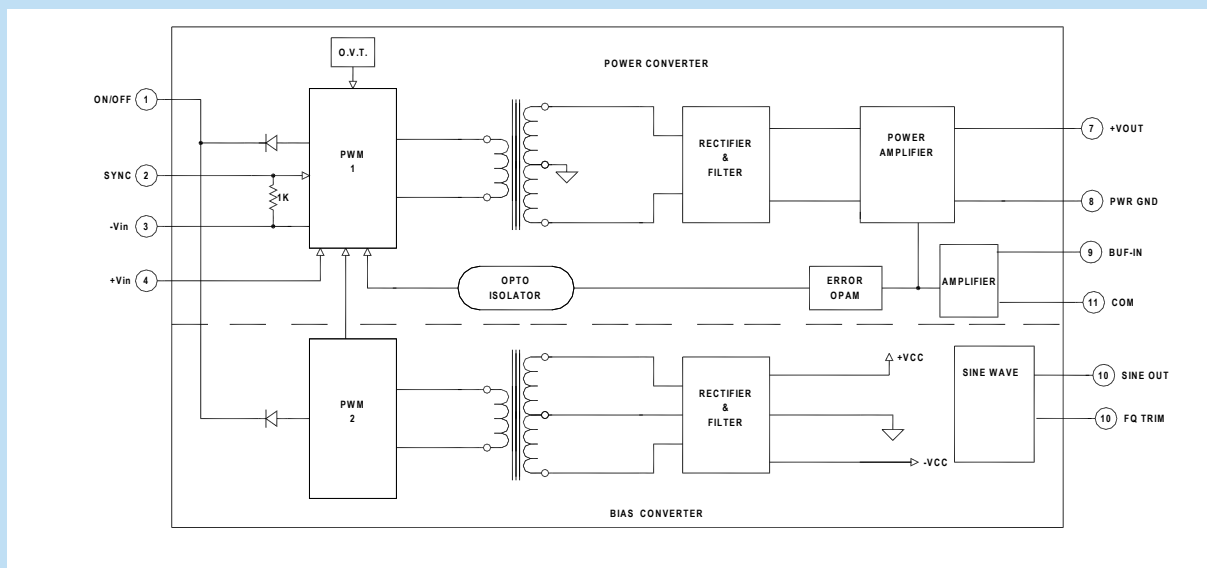

Typical Block Diagram

Ring Generator PERFORMANCE / FUNCTIONAL SPECIFICATIONS

Unless otherwise specified, all parameters are given under typical +25°C with nominal input voltage and under full output load conditions.

Specifications typical at: $T_A = +25^\circ\text{C}$, $V_{IN} = \text{nominal}$, $V_{OUT} = 70V_{RMS}$, $REN=15$ ($C_1 = 144\mu\text{F}$, $R_L=455\Omega$)
Setup according to Typical Application 1. See Application Note RG-001.

PARAMETER	CONDITION / NOTE	MIN	TYP	MAX	UNIT
SUPPLY					
Supply Voltage (V_{IN})	See Table				Vdc
Conducted Noise	Conducted current noise measured through + V_{IN} terminal with DC power source impedance of maximum 0.1 Ω .		200		mA_{PP}
Switching Frequency		260	280	290	kHz
Remote ON/OFF					
Ringer ON	Pin 1 open (open circuit voltage is 12V)				
Ringer OFF		0		.8	Vdc
Input Logic Reference	-Vin Pin 3 for ON/OFF and Sync				
Synch High		2		5	Vdc
Synch Low		0		.8	Vdc
Under Voltage Threshold, $V_{IN\ UV}$	See Table				Vdc
Over Voltage Threshold, $V_{IN\ OV}$					Vdc
Recovery from UV/OV				1	S
Current Consumption, Device Off	Pin 1 connected to Pin 2		1	2	mA
Current Consumption, No Load	Pin 1 = open, Vdc at Pin 1 = 10V See Table				
Current Consumption, Full Load	Pin 1 = open, Vdc at Pin 1 = 10V See Table				
OUTPUT					
Power	Continuous loading	17	20	25	VA
Power Factor (PF) (cos θ)	$R_L = 455\Omega$, $C_L = 144\mu\text{F}$		0.983	1	
Output Voltage		0	70	78	V_{RMS}
Amplitude TC	-40° to +85°C, $V_O = 200V_{PP}$		0.08		$V_{PP}/^\circ\text{C}$
Output Capacitance		0.15			μF
Voltage Accuracy			± 1	± 2	%
Line Regulation			± 1	± 2	%
Load Regulation			± 2	± 2	%
Combined Regulation			± 2	± 5	%
Output Frequency, $R_{ADJ} = \infty$			20		Hz
Output Frequency, $R_{ADJ} = 0$	Refer to the Output Frequency Setting table		80		Hz
Frequency Accuracy			1	± 2	%
THD			1.0	3.0	%
Sinewave Frequency TC	-40°C to +85°C		0.12		%FS/°C
Turn On Delay			500		mS
Sine Amplitude			6.6		V_{PP}
Isolation			1500		Vdc
THERMAL					
Operating Temperature Range	$R_L = 455\Omega$, $C_L = 144\mu\text{F}$, $V_{OUT} = 70V_{RMS}$	-40		75	°C
Derating (above 65°C)	$R_L = 455\Omega$, $C_L = 144\mu\text{F}$, $V_{OUT} = 70V_{RMS}$		0.2		°C/W
Thermal Resistance				1.2	°C/W
Thermal Shutdown Case Temperature			88		°C
MTBF	per MIL-HDBK-217F (Ground benign, +25°C)		300,000		hours

Model Selection Guide

-MODEL NUMBER	INPUT						OUTPUT			
	Voltage (Vdc)			Current (mA)			Voltage (V _{rms})	Current (mA) I _{o_rms}	Efficiency Full Load (%)	
	Nominal	Range	Voltage Threshold		No Load					Full Load
			Under	Over	I _{in_rms}					I _{in_rms}
RG15012	12	9.5-18	9	20	205	1946	76	165	60	
RG15024	24	18-36	16	40	190	1270	84	183	61	
RG15048	48	36-72	34	76	160	464	77	168	64	

Efficiency measurements, input and output currents taken with a Voltech PM100 Power Analyzer

Table 1. Output Frequency Settings

F _{OUT} (Hz)	R _{Trim}
20.6	OPEN
25	80K
30	30K
35	18K
40	11.4K
45	7.5K
50	5.6K
55	4.0K
60	3.0K
65	2.2K
70	1.4K
75	1K

Table 1. Output Voltage Settings

R	V _{or_{ms}}
47K	15
24K	24
13K	35
10K	40
7.5K	45.6
5.7K	50.4
4.3K	55
3.3K	60
2.2K	65
1.2K	70
0.4K	75
0	80

Output Specifications

Figure 1. Typical Connection Diagram

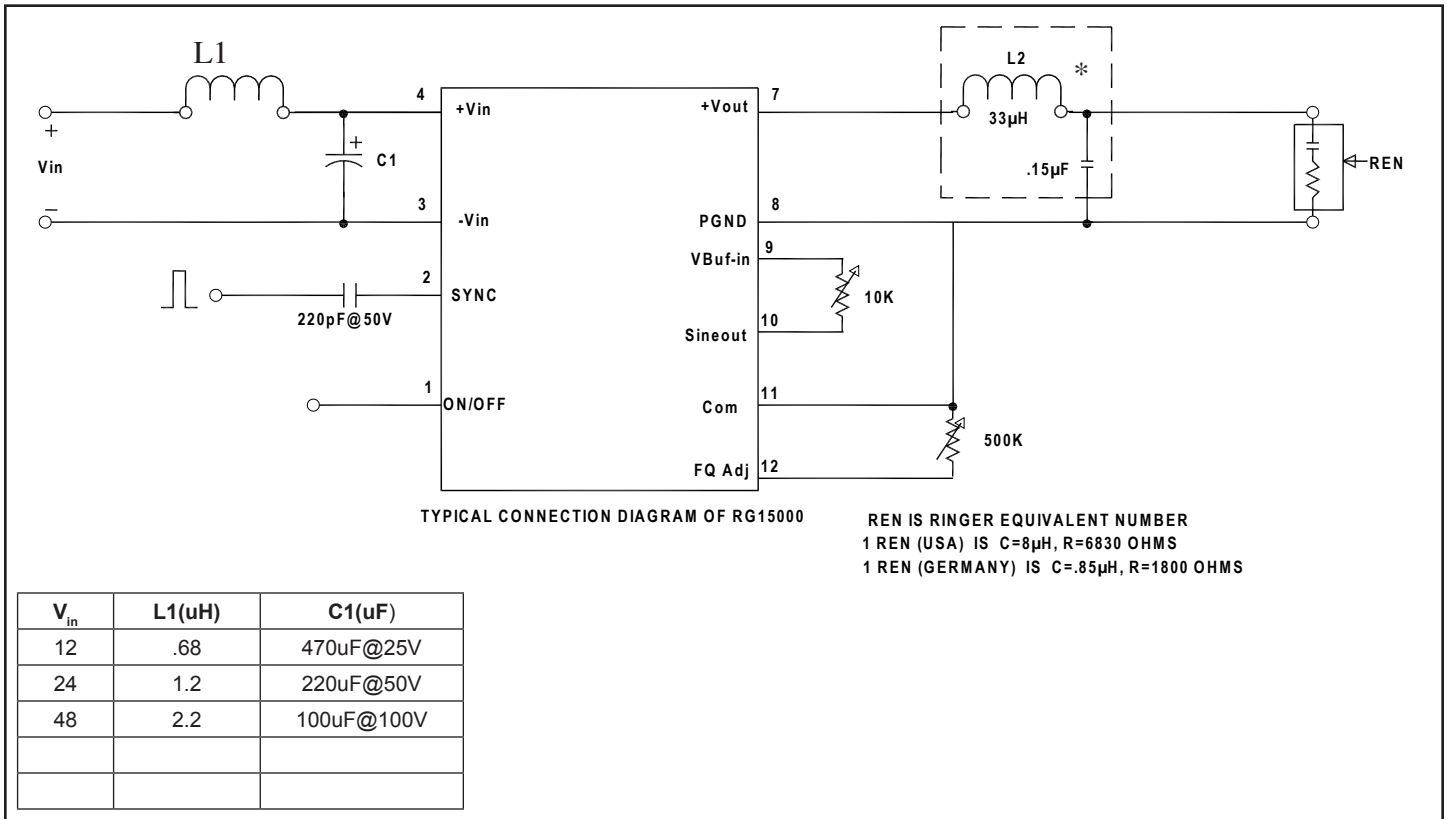

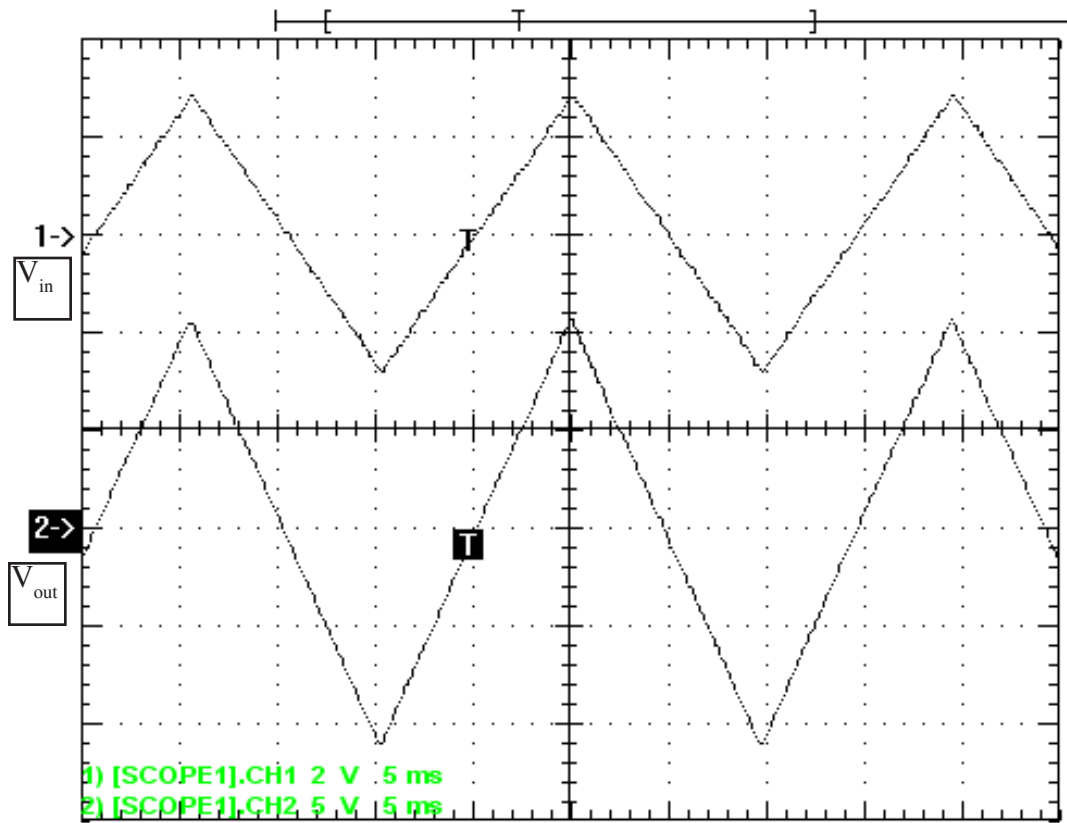

Figure 2. Vin vs. Vout

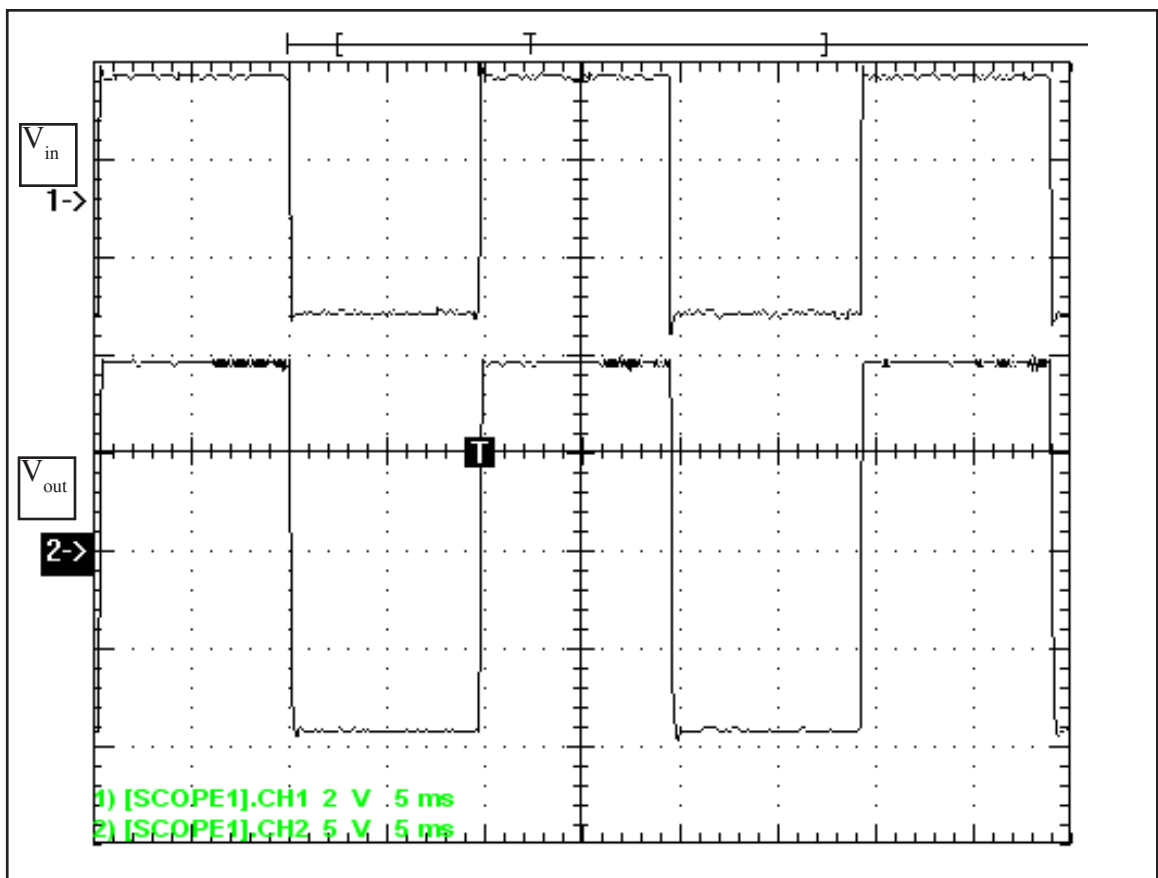

Figure 3. Vin vs. Vout

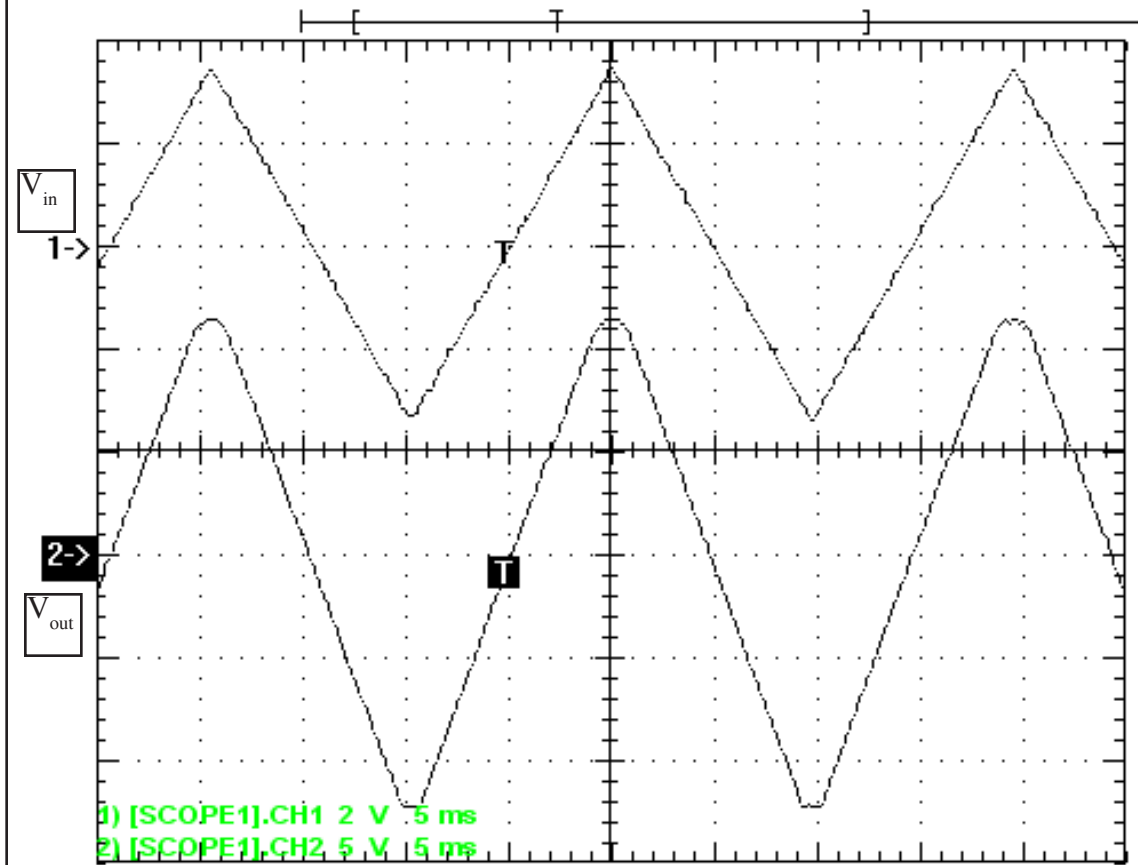

Figure 4. V_{in} vs. V_{out}

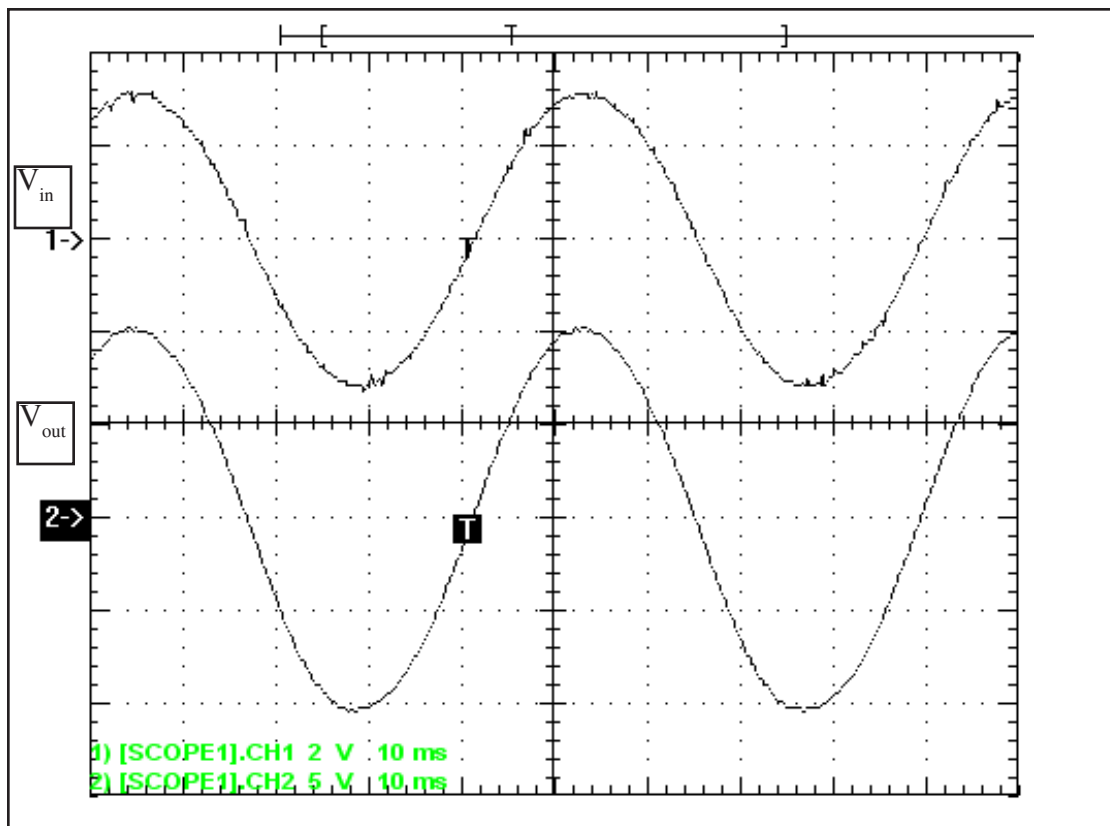
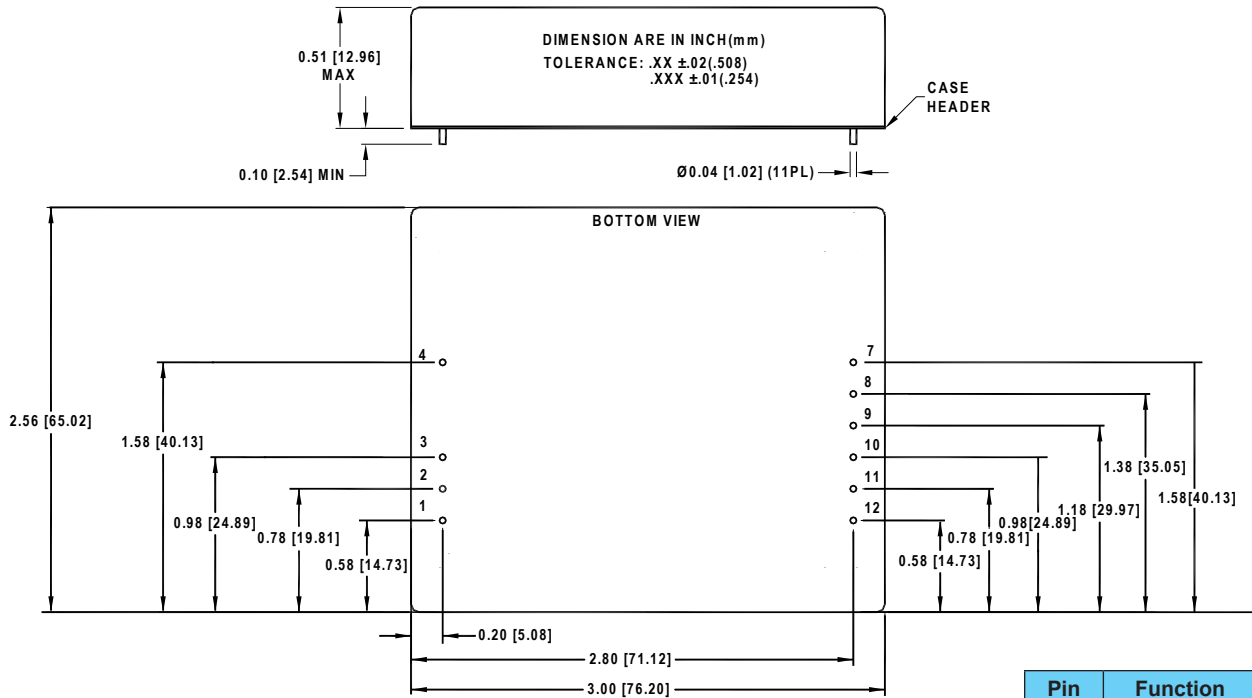

Figure 5. V_{in} vs. V_{out}

MECHANICAL SPECIFICATIONS
in inches [mm]



Pin	Function
1	ON/OFF
2	SYNC
3	-V _{IN}
4	+V _{IN}
7	+V _{OUT}
8	PWR GND
9	BUFFER IN
10	SINE OUT
11	COMMON
12	FQ TRIM