

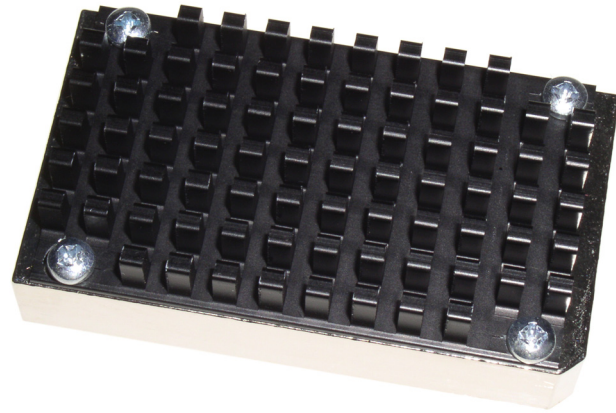

PowerWatt™
Q75 QUARTERBRICK SERIES
75W SINGLE DC/DC CONVERTERS
Six-Sided Shielding, Industry Standard Pinouts
US Patent 6,473,317 B1

Key Features

- Efficiency up to 93%
- Six-sided shielding
- Power density of 98W/in³
- 100µS transient response time
- 500µA off state current
- Output synchronous rectification
- 2:1 input voltage range
- Input-to-output isolation
- Soft start
- Short circuit protection
- Thermal protection
- Undervoltage protection
- External synchronization (Optional)



Beta Dyne is protected under various patents, including but not limited to U.S. Patent numbers: 5,777,519; 6,188,276; 6,262,901; 6,452,818; 6,473,317.

Applications

- Electronic Data Processing (EDP)
- Instrumentation/Industrial/Medical
- Communications
- Computers
- Fiber Optics

Functional Description

The Q75 Quarterbrick Series is a family of 75W single-output DC/DC converters that feature an input voltage range of 18–72V_{IN} and an output range of 1.8–24V_{OUT}. Their high efficiency and power density are a result of innovative patented designs utilizing improved synchronous rectification techniques and planar magnetics. The thermal resistance from the semiconductor and its planar magnetics to the case is minimized by the nickel-plated aluminum case and proprietary potting material. The aluminum heat sink further reduces the thermal resistance from case to ambient. The converter also offers six-sided shielding to eliminate EMI and RFI, resulting in an ideal power source for applications that require low levels of radiated noise.

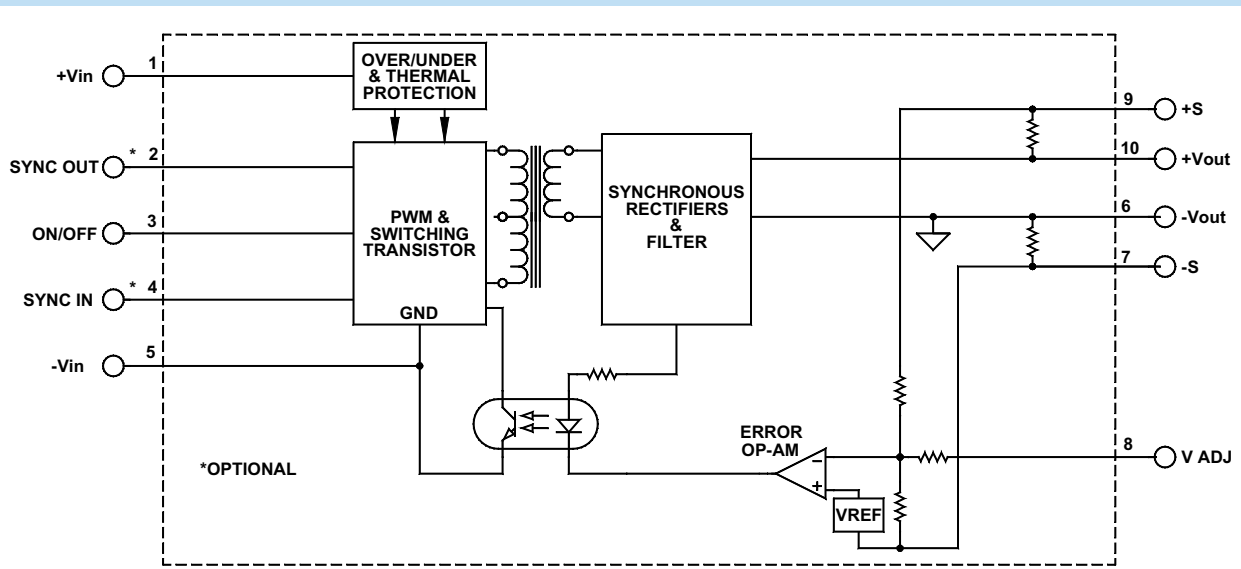

Typical Block Diagram

NOTICE: Do not operate this converter with a floating case. Connect the case to either +V_{IN} or -V_{IN}.

Unless otherwise specified, all parameters are given under typical ambient temperature of +25°C with an airflow rate = 400LFM. With the given power derating, the operating range is -40°C to +125°C. Specifications subject to change without notice.

Electrical Specifications

ABSOLUTE MAXIMUM RATINGS

PARAMETER / VALUE / UNIT	PARAMETER / VALUE / UNIT
Input Voltage Non-operating..... 75Vdc continuous Operating..... 75Vdc continuous	Voltage at On/Off Input Pin..... +40/-1Vdc Semiconductor Junction Temperature..... 150°C PCB Operating Temperature..... 150°C
Input/Output Isolation..... 1500Vdc	Pins Current Rating..... 30A@25°C
Operating Case Temperature..... -40 to +110°C	Output Capacitance..... 20,000µF
Storage Temperature..... -55 to +125°C	

INPUT SPECIFICATIONS

PARAMETER	CONDITION / NOTE	MIN	TYP	MAX	UNIT
Input Voltage Range	See Model Selection Guide				
Input Startup Voltage, 48V _{IN}				35	Vdc
Input Startup Voltage, 24V _{IN}				16.5	Vdc
Undervoltage Shutdown, 48V _{IN}		32			Vdc
Undervoltage Shutdown, 24V _{IN}		16			Vdc
Input Filter	Capacitor				
Reflected Ripple	See Model Selection Guide, Figure 1				mA _{PP}
No Load Input Current	See Model Selection Guide				
Input Surge Current (20µs Spike)				10	A
Short Circuit Current Limit			125	150	% I _{IN} Max
Off State Current			150		µA
Remote ON/OFF Control					
Supply ON	Pin 5 Open (Open circuit voltage: 12V Max.)				
Supply OFF		0		0.8	Vdc
Logic Input Reference					
Logic Compatibility	TTL Open Collector or CMOS Open Drain				
Sync In Pulse Width		300			nS
Sync Out Source Current		2.5	5		mA

OUTPUT SPECIFICATIONS

PARAMETER	CONDITION / NOTE	MIN	TYP	MAX	UNIT
Voltage and Current Ratings	See Model Selection Guide				
Output Voltage Accuracy			±1		%
Output Voltage Adjustment	See also footnote 3 in Model Selection Guide		±5		%
Output Capacitance, V _O 5V		470	1000	20000	µF
Output Capacitance, V _O 18V		100	220	1000	µF
Ripple & Noise	Case must be grounded, see page 13		1	2	%V _{PP} of V _{OUT}
Line Regulation	Minimum V _{IN} to maximum V _{IN}		±0.25	±0.5	%
Load Regulation	10% FL to FL		±0.25	±0.5	%
Output Minimum Load		5	10		%
Temperature Coefficient @ FL			0.02		%/°C
Transient Response Time	50% FL to FL to 50% FL, See Figure 3		50	100	µS
Short Circuit Protection	By input current limiting				
Turn On Delay with Soft Start	See Figure 4		3	4	mS
Output Overvoltage Protection	None,				

GENERAL SPECIFICATIONS

PARAMETER	CONDITION / NOTE	MIN	TYP	MAX	UNIT
Efficiency (at full power)	See Model Selection Guide, Figures 2 & 5				
Isolation Voltage (1 min.), Input to Output	All models		1500		Vdc
Isolation Resistance			10 ⁹		Ω
Isolation Capacitance			300		pF

ENVIRONMENTAL SPECIFICATIONS

PARAMETER	CONDITION / NOTE	MIN	TYP	MAX	UNIT
Operating Temperature Range (Ambient)	Industrial, See Figure 10	-40		+71	°C
Storage Temperature Range		-55		+150	°C
Maximum Operating Case Temperature	Case must be grounded, see page 13			110	°C
Derating	See Figure 10				
Thermal Resistance, With Heat Sink ⁴	Zero air flow		7.8		°C/W
Cooling	See Figure 10				
Case Connection	CASE MUST BE CONNECTED TO EITHER INPUT OR OUTPUT POWER PINS				
MTBF	per MIL-HNBK-217F (Ground benign, +25°C)		1.1×10 ⁶		hours

PHYSICAL CHARACTERISTICS

PARAMETER	CONDITION / NOTE	MIN	TYP	MAX	UNIT
Dimensions, With Heat Sink (L×W×H)	2.50×1.40×0.75 in. (63.50×35.56×19.05mm)				
Dimensions, Without Heat Sink (L×W×H)	2.50×1.40×0.47 in. (63.50×35.56×11.94mm)				
Weight, With Heat Sink	3.2 oz. (90g)				
Weight, Without Heat Sink	2.6 oz. (74g)				

Model Selection Guide

MODEL NUMBER	INPUT				Reflected Ripple ² (mA _{PP})	OUTPUT			
	Voltage (Vdc)		Current (mA)			Voltage (Vdc)	Current (A)	Efficiency (%)	
	Nominal	Range	No Load	Full Load ¹				50% FL	100% FL
Q75S1.8/24 ³	24	18–36	160	1786	80	1.8	20	86	84
Q75S2.5/24	24	18–36	160	2422	80	2.5	20	88	86
Q75S3.3/24	24	18–36	160	3230	80	3.3	20	90	86
Q75S5/24	24	18–36	160	3511	80	5.0	15	91	89
Q75S10/24	24	18–36	160	2940	80	10	6	87	85
Q75S12/24	24	18–36	160	2874	80	12	5	90	87
Q75S15/24	24	18–36	160	2841	80	15	4	90	88
Q75S18/24	24	18–36	160	3450	80	18	4	92	87
Q75S24/24	24	18–36	240	3550	80	24	3.125	90	88
Q75S1.8/48 ³	48	36–72	90	8823	40	1.8	20	88	85
Q75S2.5/48	48	36–72	90	1197	40	2.5	20	90	87
Q75S3.3/48	48	36–72	90	1559	40	3.3	20	92	89
Q75S5/48	48	36–72	90	1736	40	5.0	15	93	90
Q75S10/48	48	36–72	90	1453	40	10	6	88	86
Q75S12/48	48	36–72	90	1705	40	12	6	91	88
Q75S15/48	48	36–72	90	1736	40	15	5	91	90
Q75S18/48	48	36–72	90	2106	40	18	5	91	89
Q75S24/48	48	36–72	90	1736	40	24	3.125	92	90

¹ The maximum input current at any given input range measured at minimum input voltage is given as 1.6*I_{NOMINAL}. Nominal input current is the typical value measured at the input of the converter under full-load room temperature and nominal input voltage (24Vdc and 48Vdc).

² Measured with 22µF capacitor for 48V_{IN} and 100µF capacitor for 24V_{IN} at the input power pins in series with 10µH inductor (see Figure 1A).

³ The 1.8V_{OUT} models have ±20% output voltage adjustment range from 1.5V_{OUT} to 2V_{OUT}.

⁴ See Application Note DC-004: Thermal Considerations for DC/DC Converters.

ORDERING GUIDE

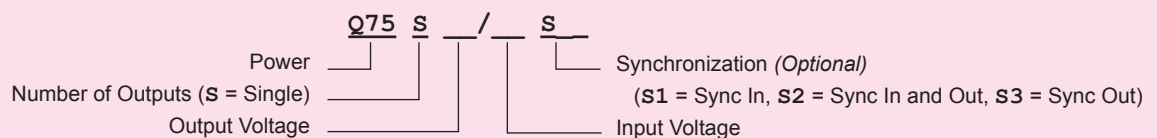

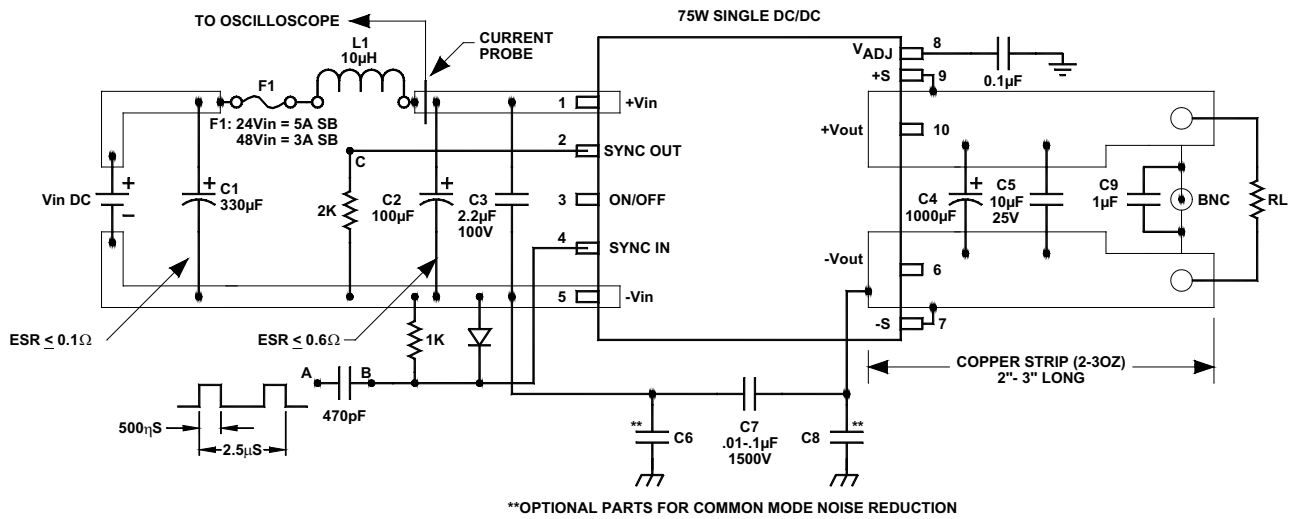

FIGURE 1A. Setup for output and reflected ripple measurement

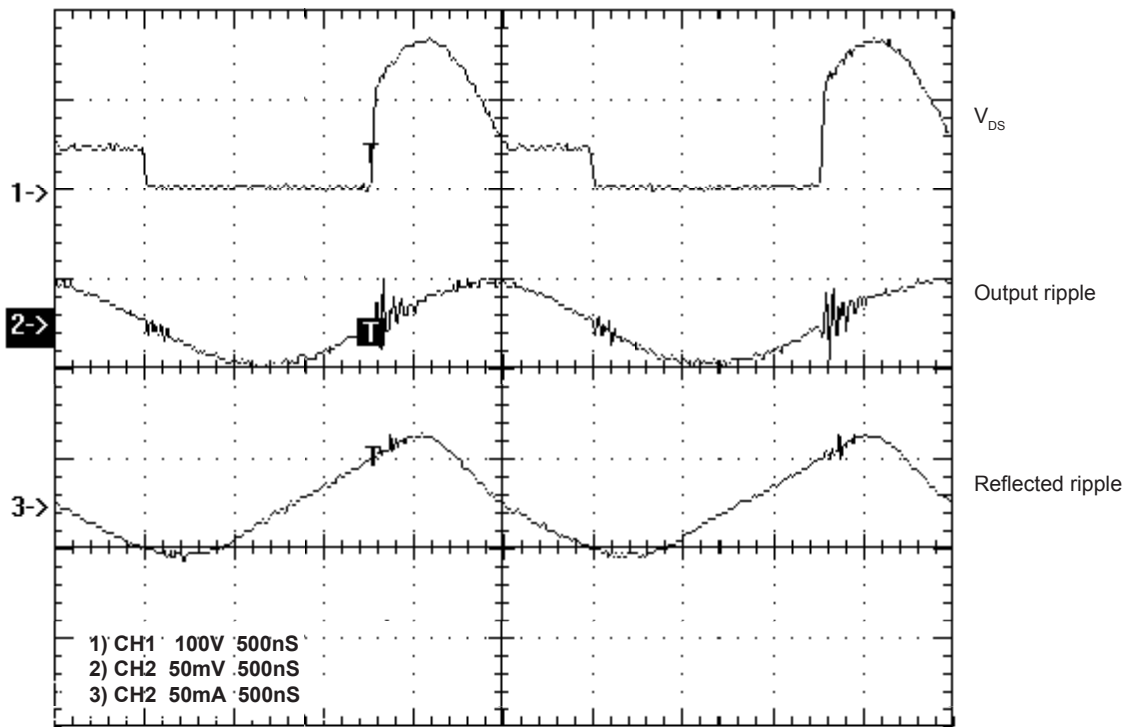

FIGURE 1B. Typical output ripple and reflected ripple of Q75S5/48 ($C_4 = 1000\mu\text{F}$)

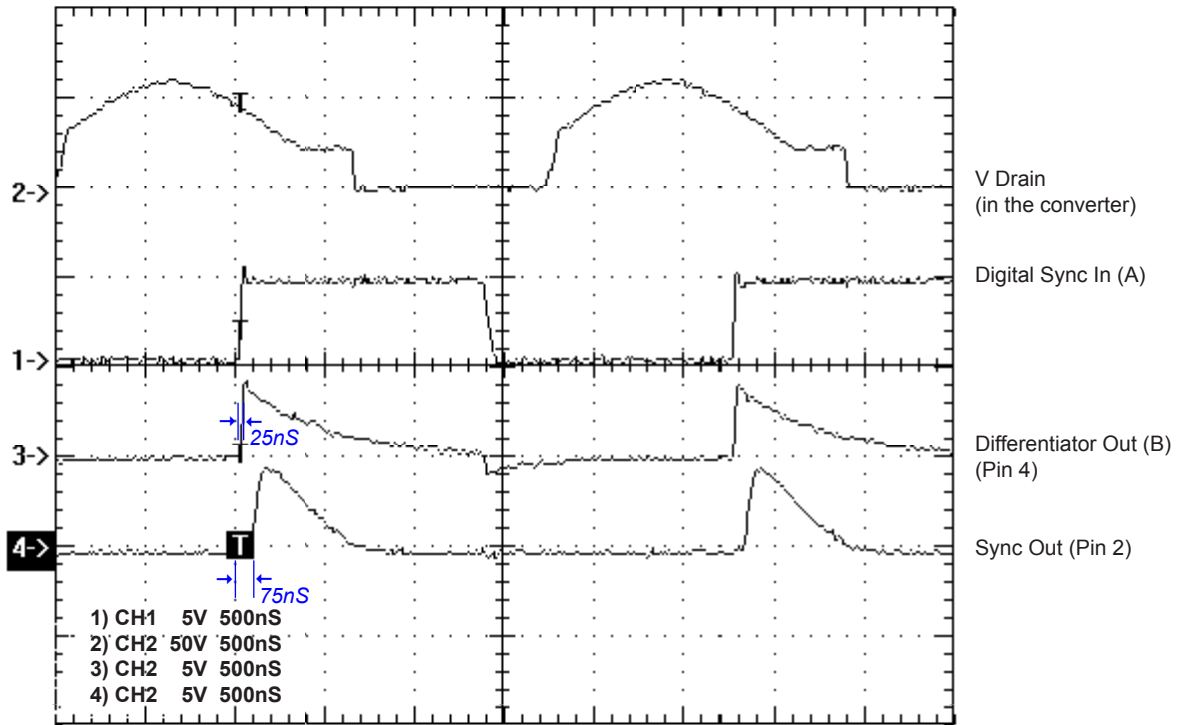

FIGURE 1C. Typical synchronization waveforms obtained from connection diagram in Figure 1 (Q75S3.3/24)

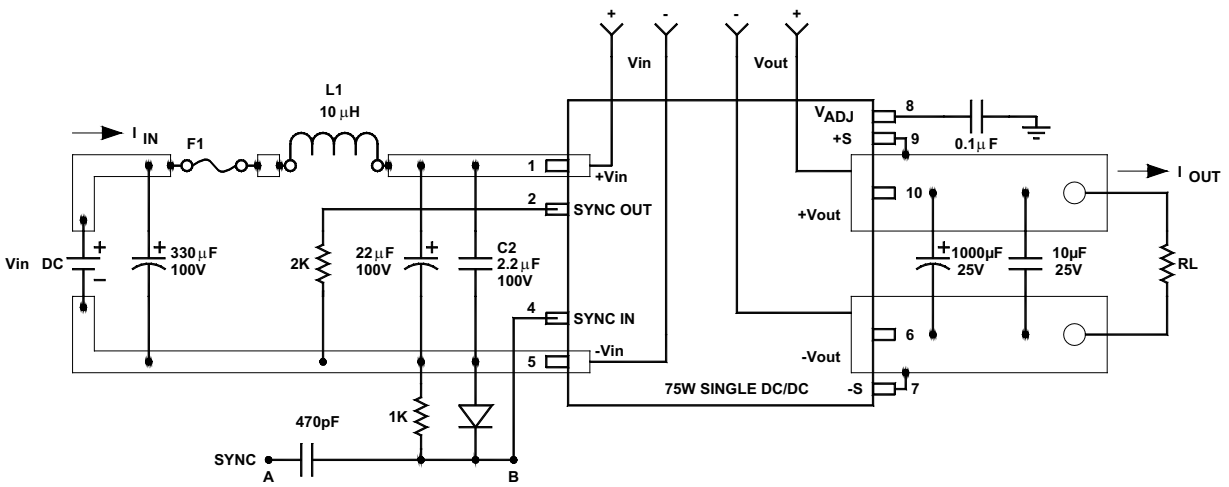

FIGURE 2. Setup for efficiency measurements

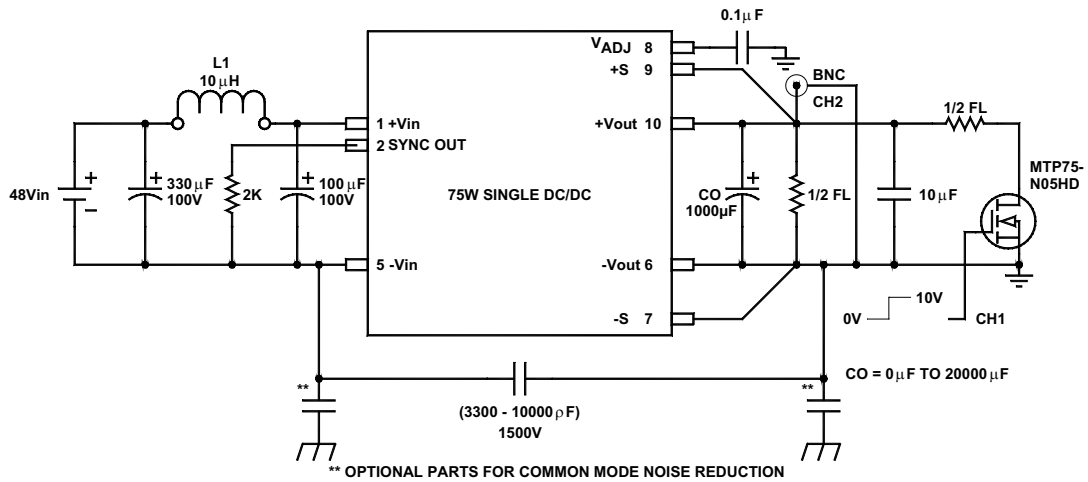

FIGURE 3A. Setup for transient response measurements

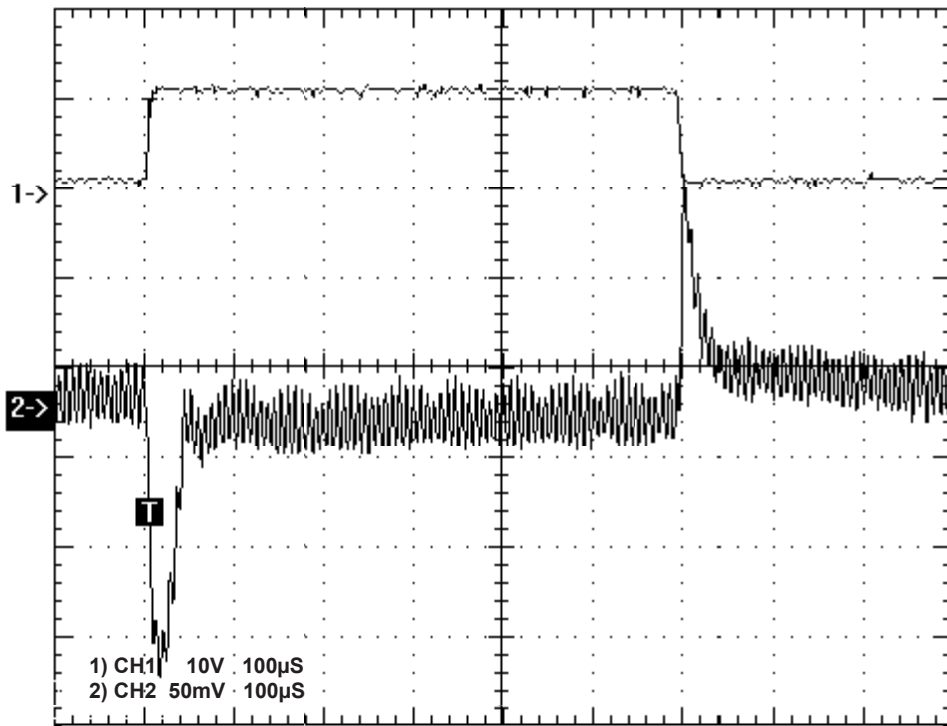

FIGURE 3B. Typical transient response of Q75S3.3/48 ($C_o = 1000\mu\text{F}$, $I_o = 50\% \text{ FL to FL}$)

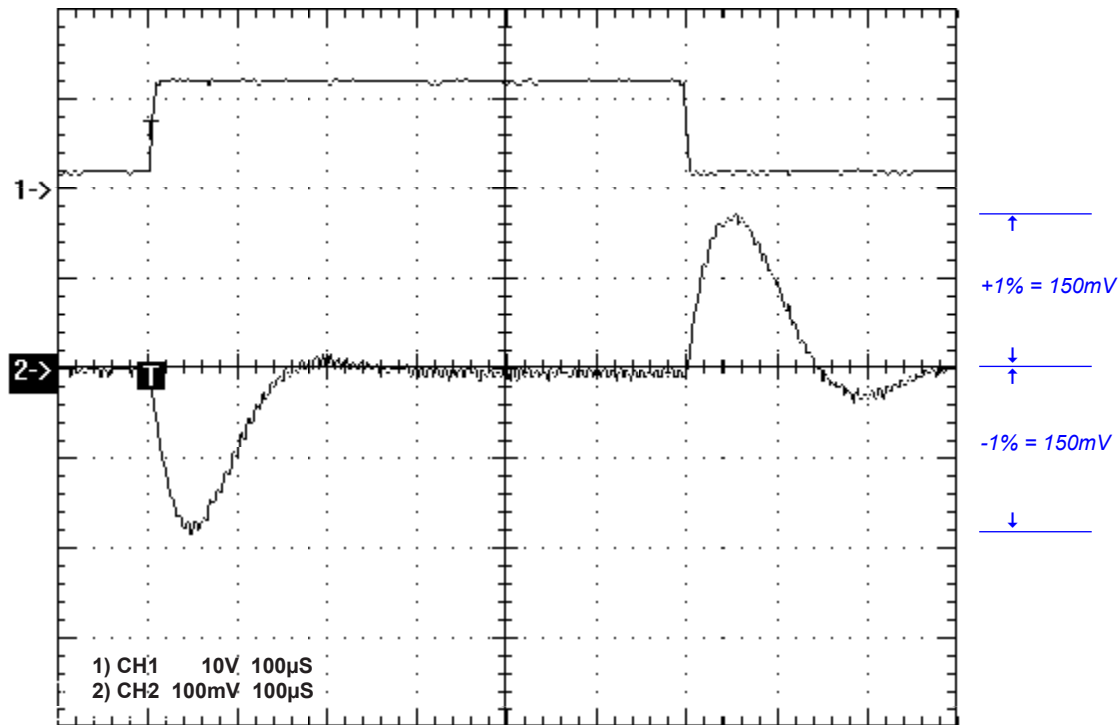

FIGURE 3C. Typical transient response of Q75S15/24
($C_o = 250\mu\text{F}$, 50% $I_o = 2\text{A}$)

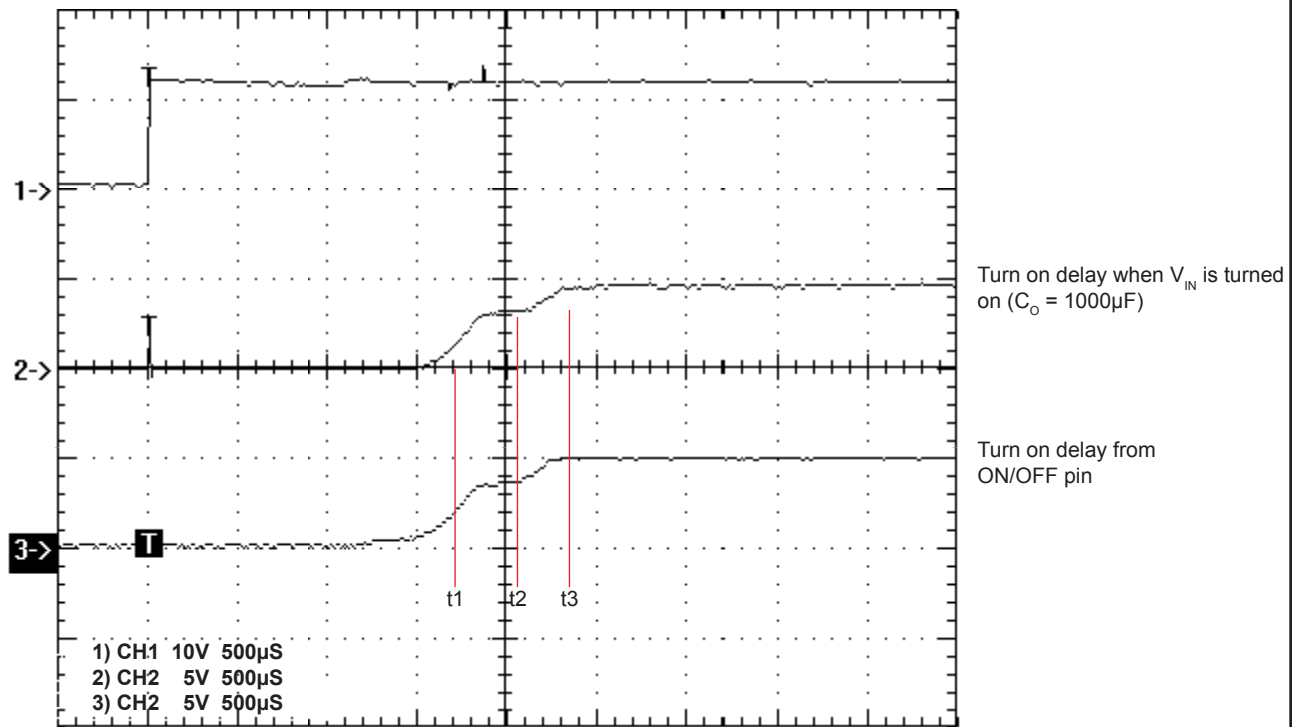

FIGURE 4. Turn on delays
(Refer to Figure 3A)

NOTE: From t_1 to t_2 , the secondary voltage is rectified by the MOSFET parasitic diodes. From t_2 to t_3 , a switchover from diode rectification to synchronous rectification occurs.

EXTERNAL TRIMMING OF OUTPUT VOLTAGES

To trim the output voltage DOWN, connect a 5% ¼W resistor between the + (plus) output and trim pin of the converter. To trim the output voltage UP, connect a 5% ¼W resistor between the – (minus) output and trim pins of the converter. For UP/DOWN trimming capability, connect a 10kΩ potentiometer between the + and – output pins, with the wiper arm connected to the trim pin.

The trim resistors/potentiometer can be connected at the converter output pins or the load. However, if connected at the load,

the resistance of the runs becomes part of the feedback network which improves load regulation. If the load is some distance from the converter, the use of #20 gauge wire is recommended to avoid excessive voltage drop due to the resistance of the circuit paths.

See our application notes:

DC-001: Testing Transient Response in DC/DC Converters

DC-004: Thermal Consideration for DC/DC Converters

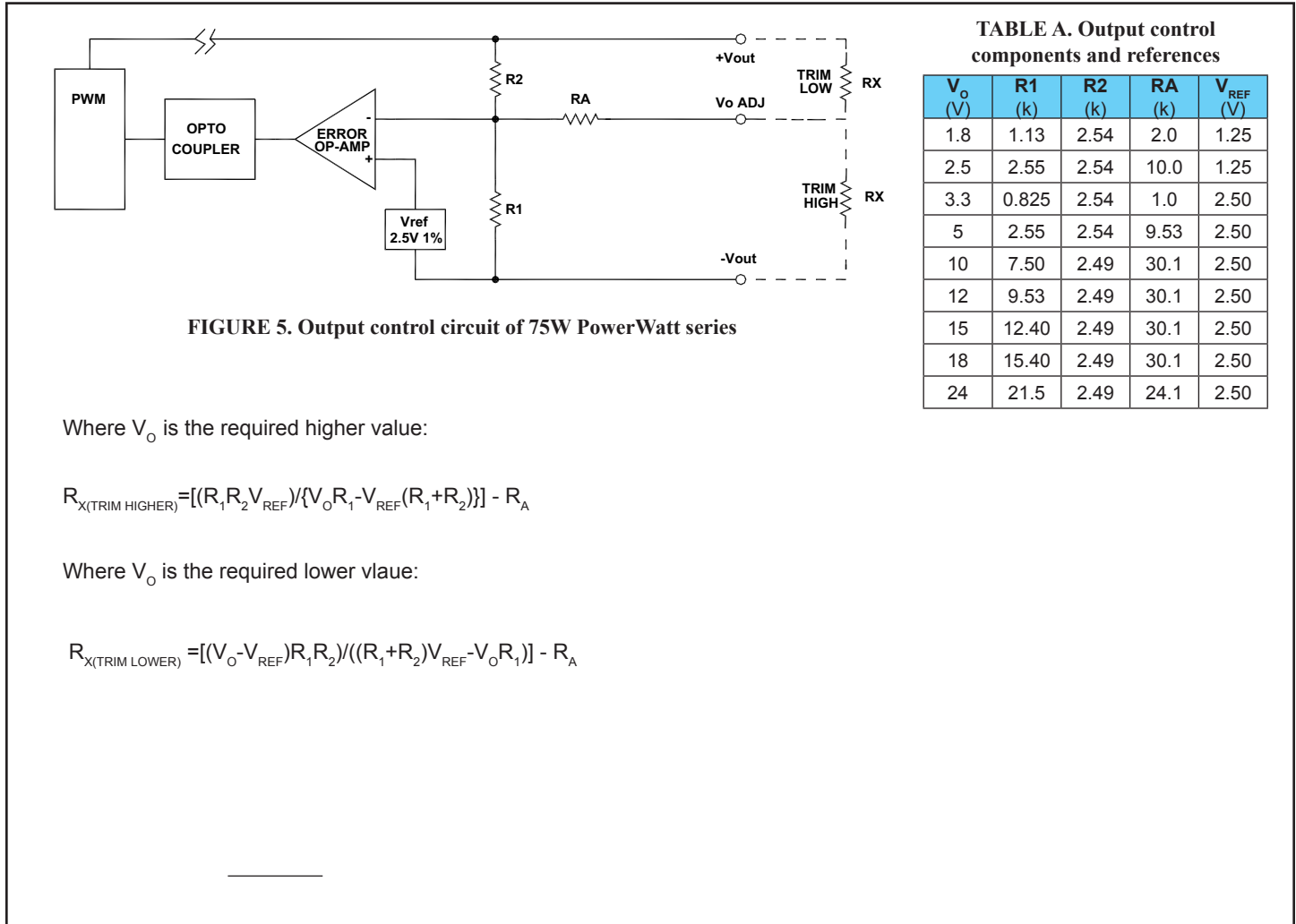

Where V_o is the required higher value:

$$R_{X(\text{TRIM HIGHER})} = [(R_1 R_2 V_{REF}) / (V_o R_1 - V_{REF} (R_1 + R_2))] - R_A$$

Where V_o is the required lower value:

$$R_{X(\text{TRIM LOWER})} = [(V_o - V_{REF}) R_1 R_2] / ((R_1 + R_2) V_{REF} - V_o R_1) - R_A$$

EXTERNAL SYNCHRONIZATION

A TTL signal applied at the SYNC pin of the converter will synchronize the switching frequency of the converter to that of the TTL input signal. The external (TTL) frequency must be equal or higher than the converter's frequency. At the positive-going edge of the applied pulse, the internal power-switching transistor turns off and the PWM discharges its timing capacitor. At the negative-going edge, the PWM resumes normal operation. The minimum positive pulse width of the TTL signal must be 300nS and its frequency between 350kHz and 410kHz.

NOTE: Higher frequencies will reduce the efficiency of the converter and wide TTL pulses will force the PWM to follow the external TTL width modulation, which may effect regulation. A high TTL signal at the SYNC pin of the converter will turn the converter off. An internal pull-down resistor will keep this pin low when it is not used. A pulse differentiator (see Figure 7) can be used to shape a square wave sync signal as shown in Figure 6.

To avoid noise pickup, install a 1kΩ resistor from the SYNC IN (Pin 4) to -V_{IN} (Pin 5). An internal current source will provide

2.5mA of current for driving another 75W converter from the SYNC OUT (Pin 2).

Please note that when the SYNC OUT pin is used to drive multiple converters, the 1kΩ sync input resistor is not required. However, a 2kΩ resistor load must be installed at the SYNC OUT pin (Pin 2) of the driving converter. The 2kΩ resistor can be the parallel combination of individual sync in resistors installed at the SYNC IN pin (Pin 4) of the converters to be driven.

For example, if a 75W converter "master" will be used to synchronize five other 75W converter "slaves," a 10kΩ resistor can be installed at the SYNC IN pin of each slave, and the SYNC OUT pin of the master can be connected to all the SYNC IN pins of the slaves.

The parallel combination of five 10kΩ resistors will provide the 2kΩ sync out load for the master. Avoid overloading the sync output current source with a resistor lower than 2kΩ. Overloading may affect the performance of the converter.

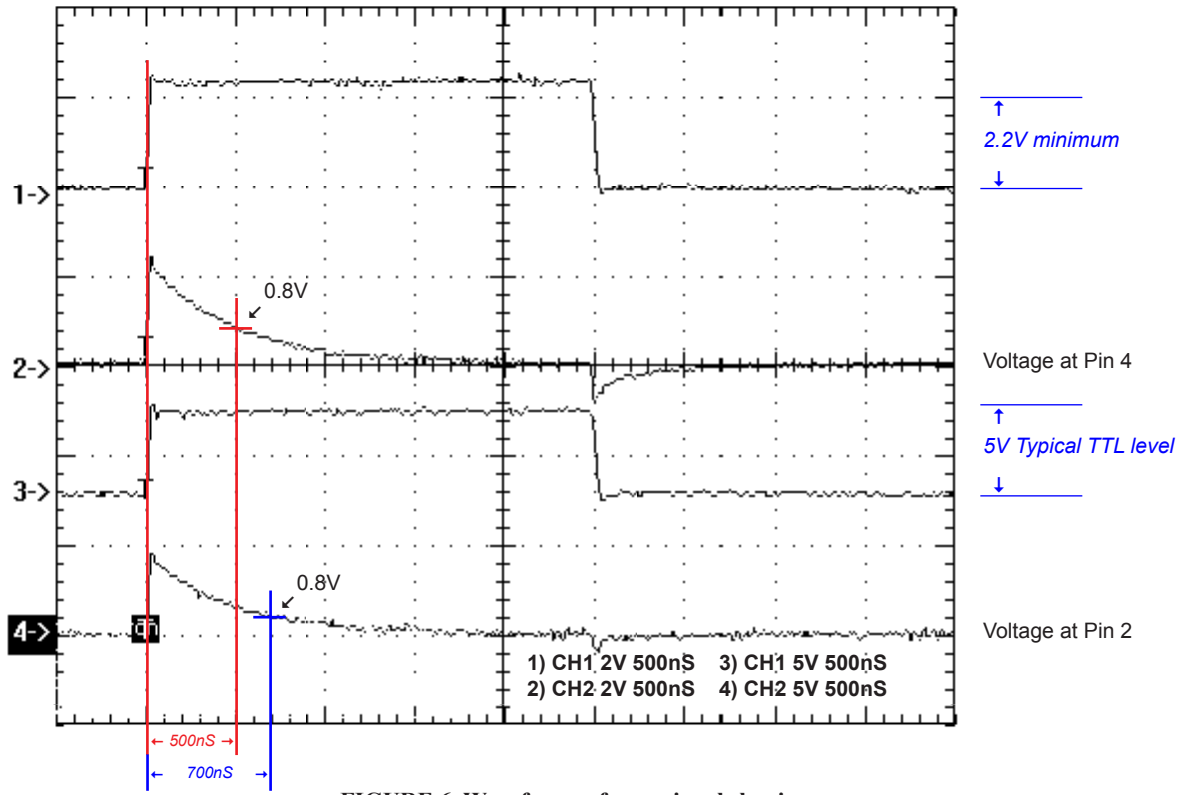

FIGURE 6. Waveforms of sync signal shaping

SYNC SIGNAL SHAPING

As described in External Synchronization, the PWM of the 75W converter requires a TTL signal of 0.8 to 2Vdc minimum amplitude and minimum duration of 300nS. When such a signal is not available (through one shot multivibrator or other pulse-shaping circuits) a C-R differentiator, such as the one in Figure 7, can be used to shape a square wave TTL signal. As is shown by the oscillogram in Figure 6, the positive edge of the sync pulse must be 2V minimum and the

decaying exponential must reach the low er threshold of 0.8Vdc in 300nS minimum from the positive edge. The parallel diode with the resistor is a small signal switching diode or a Schottky signal diode with 0.3 to 0.5V forward drop, it is used to clamp the voltage at Pin 2@-0.5Vdc. For other logic levels (such as 2.5 and 3.3), adjust the RC time constant to obtain the required timing.

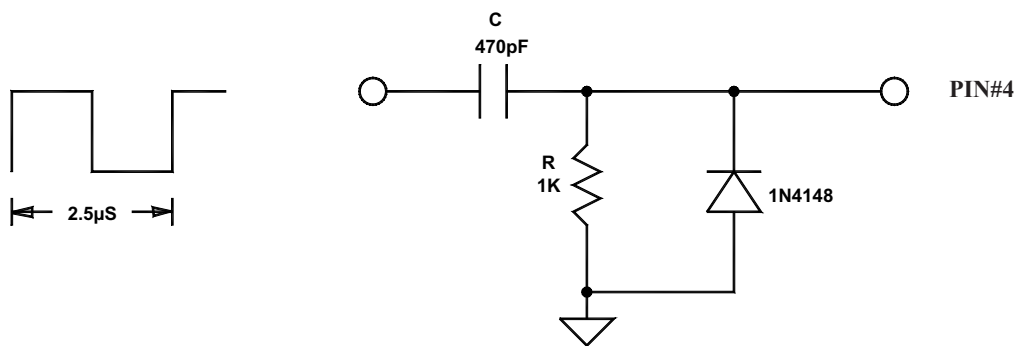

FIGURE 7. Suggested pulse-shaping circuit

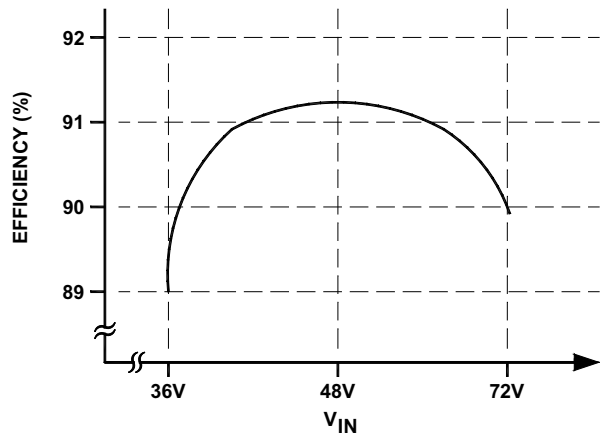

FIGURE 8A. Typical Efficiency vs. Input Line for 3.3V_{OUT}/48V_{IN}

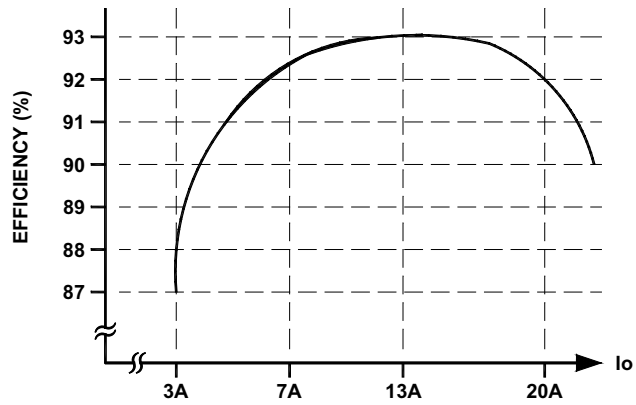

FIGURE 8B. Typical Efficiency vs. Load for 3.3V_{OUT}/48V_{IN}

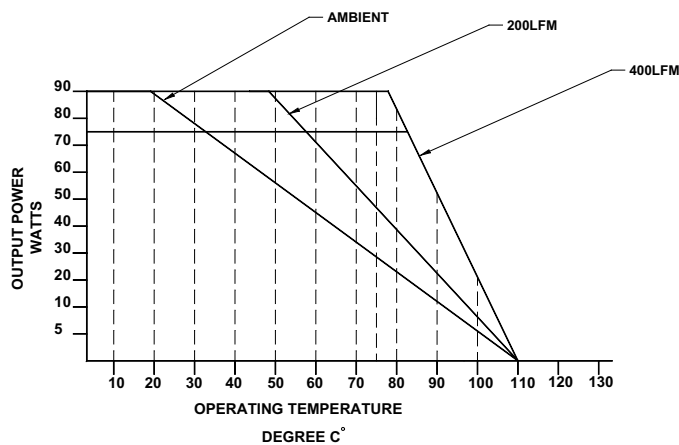

FIGURE 10A. Typical derating curves for Q75 PowerWatt series with heat sink (For output power from 75W to 90W)

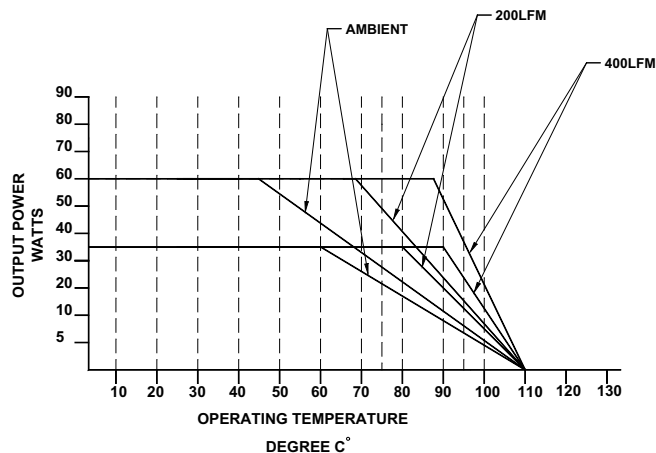
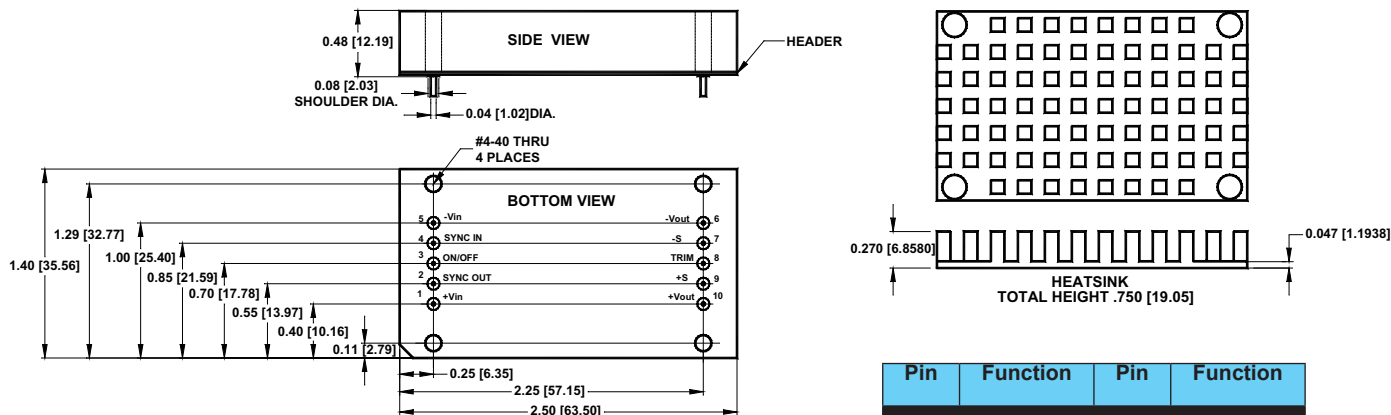

FIGURE 10B. Typical derating curves for Q75 PowerWatt series with heat sink (For output power of 60W or less)

MECHANICAL SPECIFICATIONS



Pin	Function	Pin	Function
1	+V _{IN}	6	-V _{OUT}
2	SYNC OUT*	7	-S
3	ON/OFF	8	TRIM
4	SYNC IN*	9	+S

* Optional pin, See Ordering Guide

APPLICATION CONSIDERATIONS

Pin Functions

+V_{IN} (Pin 1): For positive input power supply connections.

SYNC OUT (Pin 2): Output-driving signal of the PWM.

ON/OFF (Pin 3): Turns converter off when pulled to ground through an open collector or open drain transistor. Maximum voltage at this pin is 12V minus a diode drop. Can be parallel connected with the ON/OFF pins of multiple converters or any Beta Dyne converter that may reside in the system. Leave this pin open for continuous operation.

SYNC IN (Pin 4): Input synchronization signal to the PWM. Used to synchronize the converter to an external frequency source.

-V_{IN} (Pin 5): For negative input power supply connection (or input ground).

-V_{OUT} (Pin 6): Negative output (GND).

-S (Pin 7): Negative output voltage sense; to be connected to the negative output at the load only.

V_{ADJ} (Pin 8): Output voltage adjust; to be used for an output voltage adjustment. Bypass this pin with a 0.01 μ F to 0.10 μ F capacitor.

+S (Pin 9): Positive output voltage sense; to be connected to the positive output voltage at the load only.

DESIGN CONSIDERATIONS

Input Source Impedance

The input of the converter should be connected to a low AC-impedance source. To reduce the impedance of a potentially high-inductive DC source, use a low ESR electrolytic capacitor (ESR < 0.6W@400kHz) mounted as close to the input pins as possible to ensure stability of the converter. As suggested in Figures 1 through 3, an electrolytic capacitor (22 μ F for 48V_{IN} or 47 μ F to 100 μ F for 24V_{IN}) in parallel with an SMD 2.2 μ F ceramic capacitor will ensure stability under any line or load condition. The 330 μ F capacitor before the input inductor L1 will reduce both reflected ripple and any long wire impedance from the DC source.

Output Filter Impedance

The impedance of an output filter may also affect the stability of a converter when additional low-pass filters are used. If additional output ripple reduction is required, avoid installing series inductors at the output. Instead, try to maximize output capacitance. The inductor of the output copper strips and a 1000 μ F capacitor will be enough for most applications. Low ESR electrolytic or tantalum capacitors can be used for additional output ripple reduction in parallel with ceramic capacitors for high-frequency attenuation. We recommend Vishay Sprague 594D Solid Tantalum Chip Capacitors.

THERMAL CONSIDERATIONS

Under full load, the PowerWatt 75W converters dissipate between 6W to 10W of power (depending on the model). The generated heat is transferred to the ambient by air conduction. At room temperature without any air movement, the operating environment of the converter is higher than room temperature, 25°–50°C higher, due to the fact that air around the converter heats up.

To measure the actual operating environment of the converter in a still air environment, place a thermocoupler a half-inch above the top center of the converter. Perform the same temperature measurement in a forced air convection system and use those temperature values for your thermal calculations. Do not assume the temperature is constant throughout a forced air cooling system!

Surrounding components and the load can cause the converter to go to thermal shutdown.

The minimum junction temperature of all semiconductors is 150°C and the maximum operating temperature of the PCB is 150°C. When the temperature of the PCB reaches approximately 125°C, the converter will turn off. The thermal hysteresis of 20°–30°C will allow the converter to cool off and resume operation once it reaches approximately 95°C. If there is not enough air circulation due to air fan failure of the system or very high environmental temperatures, the converter will stay in this so-called “hiccup” (ON/OFF) thermal mode indefinitely.

EFFICIENCY MEASUREMENTS

Using the setup given in Figure 2, measure the input and output voltage at the pins at the top of the multilayer PCB and use these values to calculate the efficiency. The voltage drop at full load at the output (20A when measured from the top of the PCB to the other end of the pin) is 18mV at room temperature. Even though 18mV

does not look bad, it accounts for approximately 0.4W of power dissipation for both the positive and negative output pins for a total power dissipation of 0.8W. A poor layout can cause this worst-case scenario; see **Layout Considerations** for more details.

SHORT CIRCUIT PROTECTION

The PowerWatt series of converters has a dual short circuit protection feature. At the input side of the converter, two short circuit current comparators are used to monitor the input current of the converter. They are biased at different voltage levels; the lower threshold (LTH) comparator provides the power limiting function of the converter. Under normal operating conditions, the LTH comparator limits the output power of the converter when the maximum output power is exceeded. When a hard short is applied across the output of the converter and the input current exceeds the set threshold of

the second comparator, the converter goes into shutdown mode, the overcurrent latch is set and the converter is turned off. The converter will turn on again when its input voltage is recycled (OFF–ON) or if the ON/OFF pin is used to turn the converter on and off. The time required for the ON/OFF pin to be held low is between 100mS and 800mS.

LAYOUT CONSIDERATIONS

The maximum output current of the converter is 25A and is carried to the load through six 10A rated pins. When the converter is installed in a double-sided PCB, use both sides to connect the high current pins and use 2–3oz. copper for the plated through holes and/or power pads.

Please note that in a multilayer PCB the inner layers do not contribute much in reducing the thermal resistance of the power component, they only reduce the resistance to the load. If the top

and bottom layers of your PCB can be plated up to 3–4 oz., you do not have to use a multilayer PCB for the converter.

If the sense run length exceeds 2 inches, the sense pins may have to be bypassed at a point close to the converter. Keep in mind to bypass to their respective polarity. Avoid running digital signal lines parallel to the sense pins. If more than one power device or converter is used per system board, use a star ground connection for all power devices.

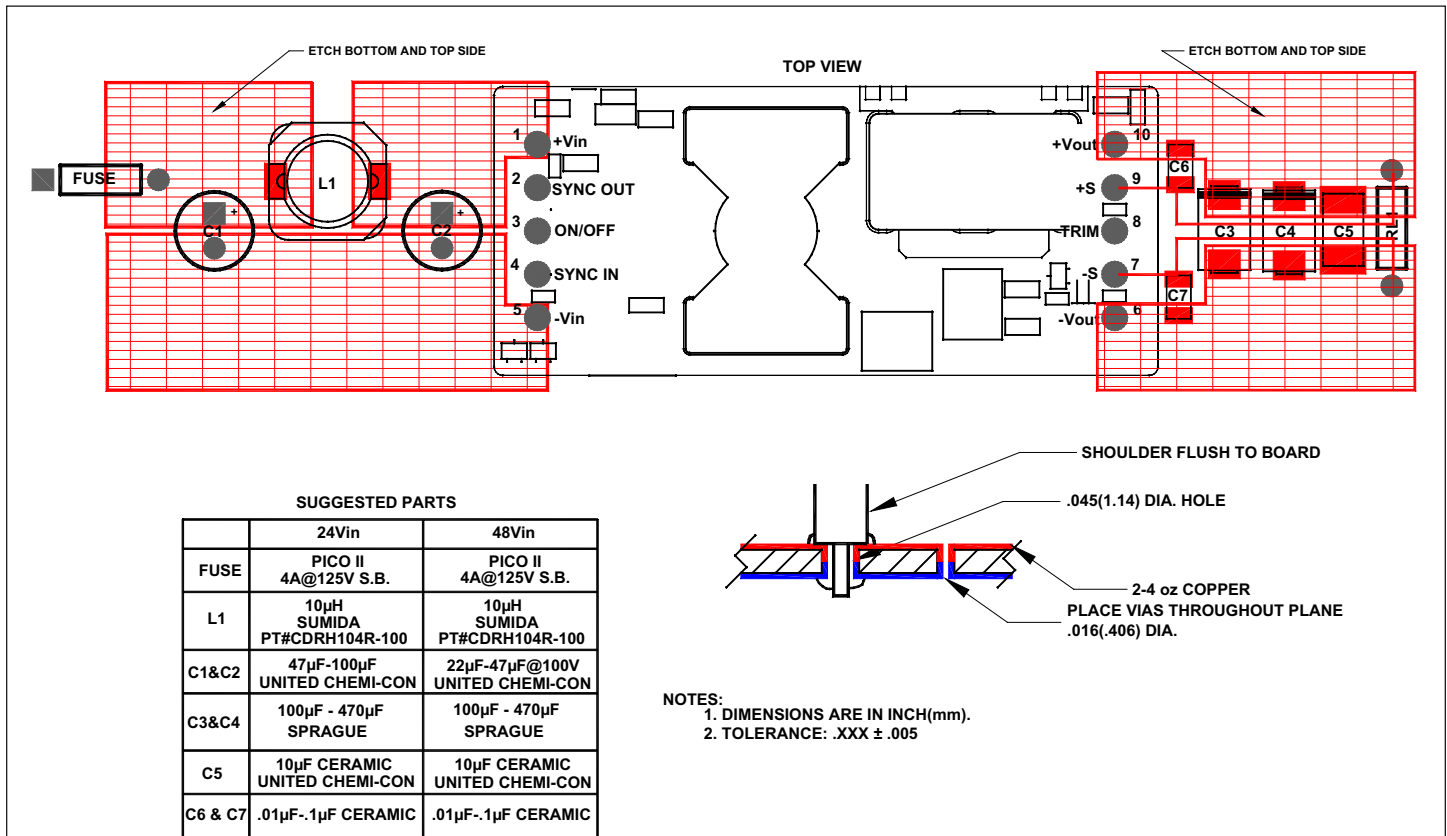

FIGURE 11. Suggested layout of Q75 PowerWatt series

EMI/RFI IN DC/DC CONVERTERS

All switching AC/DC and DC/DC converters generate noise due to high-voltage, high-current internal switching. Conducted noise is the noise that appears at the point of conduct (pins) of the converter. Radiated noise is the electromagnetic noise transmitted to the environment from the power source. Conducted noise can be reduced to acceptable levels by an input/output low-pass filter.

Manufacturers commonly use metal cases and conductive headers to provide six-sided shielding and to prevent radiated noise. The Q75 PowerWatt series provides six sided shielding by connecting the aluminum heat sink to the header. The whole case assembly can be connected to either $+V_{IN}$ (for $48V_{IN}$) or $-V_{IN}$ (for $24V_{IN}$) through the four threaded holes on the bottom of the converter. NOTE: The bottom of the converter is insulated with the non-conductive side of the header.

Effective placement and orientation of the converter in a system with forced air cooling can reduce the case temperature by 5–15°C (depending on the air flow (LFM)). When the converter is

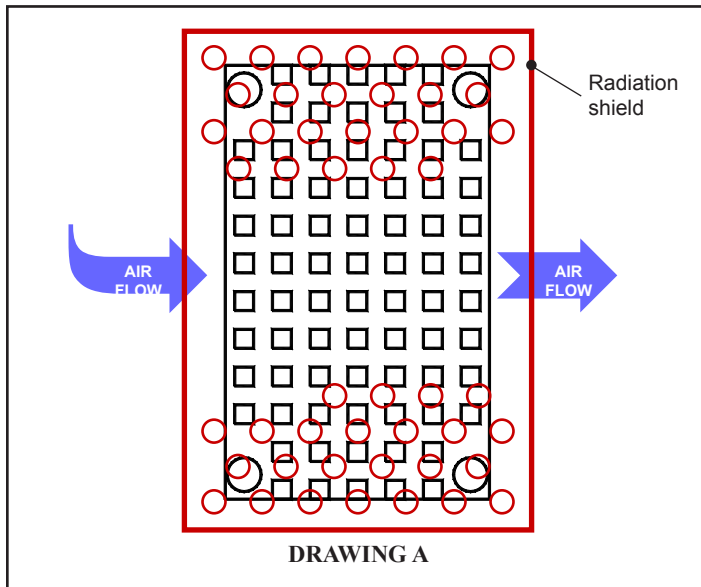

placed at the entrance and air passes over it as shown in Drawing A—from Pin 5–1 and 6–10—the lowest case temperature can be obtained.

Therefore, converters require special consideration in three critical areas—layout, radiation and cooling—that may create conflicts. We stress the importance of these critical areas:

LAYOUT RADIATION COOLING

When an open-frame converter is used to power digital circuits, radiation shielding can be implemented via the system shielding. When the load is an analog circuit—for example, A/D, D/A, RF amplifier, etc.—and these components are placed close to the converter, the radiated noise may affect signal integrity.

High impedance summing points of operational amplifiers or other components with poor power supply rejection ratio (PSRR) may be affected. In this case, local radiation shielding around the converter is necessary.

When noise creates problems in a system, it is very difficult to identify the source of the problem. A poor layout with ground loop can not only create noise it can also affect the stability of the converter or randomly trigger an event. A common problem in high

frequency and high power density DC/DC converters is the so-called “common-mode noise,” which is the noise generated from parasitic capacitors, leakage inductance, etc. in the converter.

Common-mode noise (CMN) can be bypassed to chassis with small capacitors between input and output grounds to chassis and input and output ground. Assuming the layout is correct and the converter still generates noise, the question then becomes why does the system not exhibit a noise problem when a linear voltage source is supplied?

The answer comes from the process of elimination. Replacing a switching power source of 500kHz with another one switching at 50–60Hz is not the solution. Using the “noisy” DC/DC converter, one may try the following: First, if possible, shield the converter with six-sided shielding. If the problem is still in the system, then radiated noise is not the problem! Conducted noise or poor layout are the more likely causes. As was mentioned earlier, the use of a component with poor PSRR—e.g. BICMOS, CMOS, rail-to-rail OPAMS—may be the cause of the problem.

Do not use a converter with 50mV to 100mV output ripple to power a 12-bit A/D converter. Also keep in mind that CMOS, OPAMs, A/D, and S/H may offer low power, but the parasitic capacitor from drain to gate, drain to source, and gate to source will couple any V_{DD} and V_{SS} supply noise into your signal.

Better filtering in the input or output will reduce conducted noise if they are the cause of the problem. When both radiated and conducted noise are reduced, the last potential cause is **layout**. Also, use ground plain under the converter for shielding and avoid passing signal lines under it.

In conclusion, open-frame DC/DC converters offer high efficiency, power density and low cost, but radiate a wide band of noise. For any application where the system layout is critical, select the appropriate converter(s) for the application and completely test your system during the prototyping phase. DO NOT ASSUME all is well. To make sure your prototype is functioning properly, perform a complete evaluation.

EMI/RFI PERFORMANCE OF Q75 POWERWATT SERIES

The Q75 PowerWatt series with its aluminum case and heat sink offers not only an extended operating range, but reduced radiated noise by forming an electromagnetic shield around itself when the heat sink is grounded. To test the effectiveness of the shield, the following (admittedly crude) setup was used (see Figure 12). A voltage probe was placed 0.125 inches above the center of the heat sink. With the converter under full load, two sets of data were taken at each of the following bandwidths: 6.2MHz and 50MHz. One of the data sets was taken with a floating heat sink, the other with a grounded heat sink at the input ground. The data is presented in Figures 14 and 15. The spectrum analyzer was used for power measurements, dB = 10 log x.

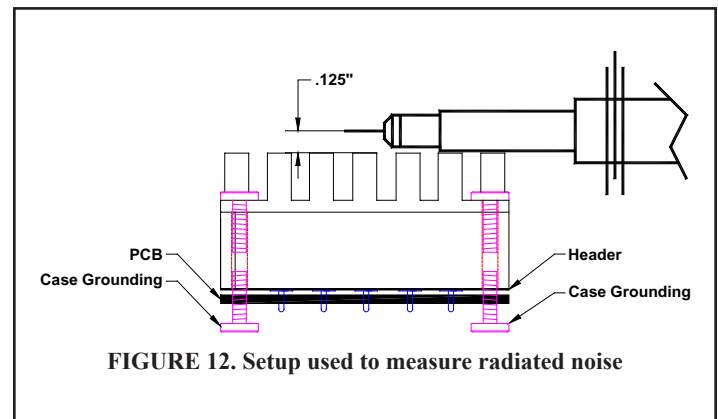

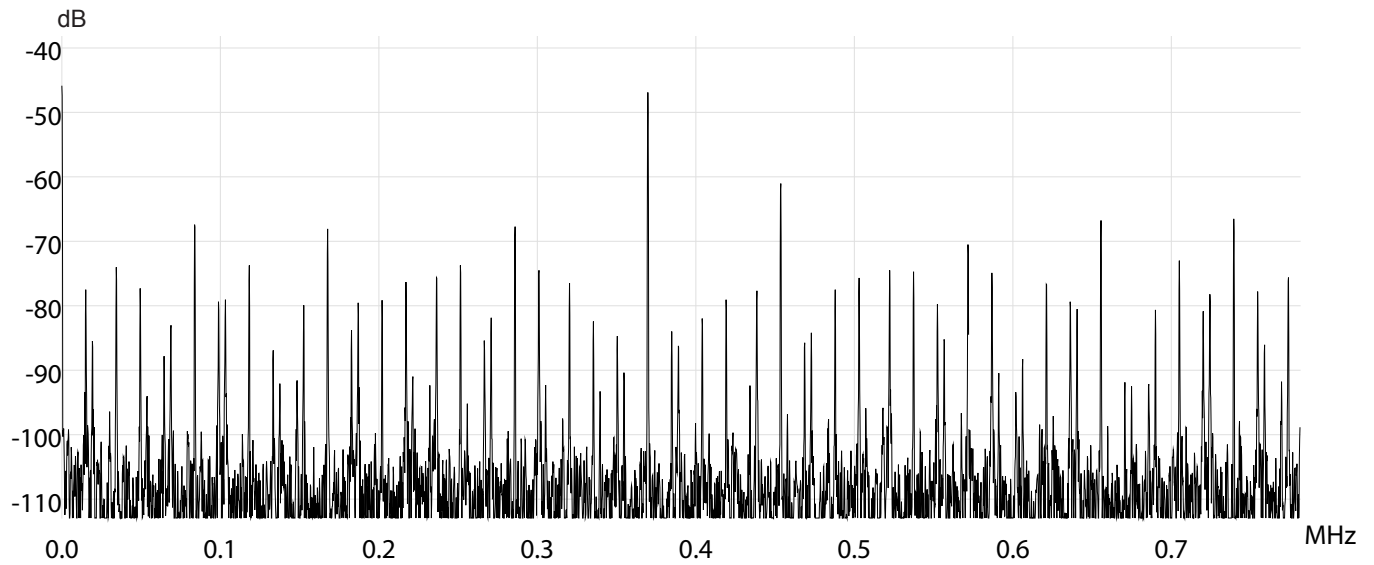

FIGURE 13A. Radiated noise of open frame converter (Q75S15/24)

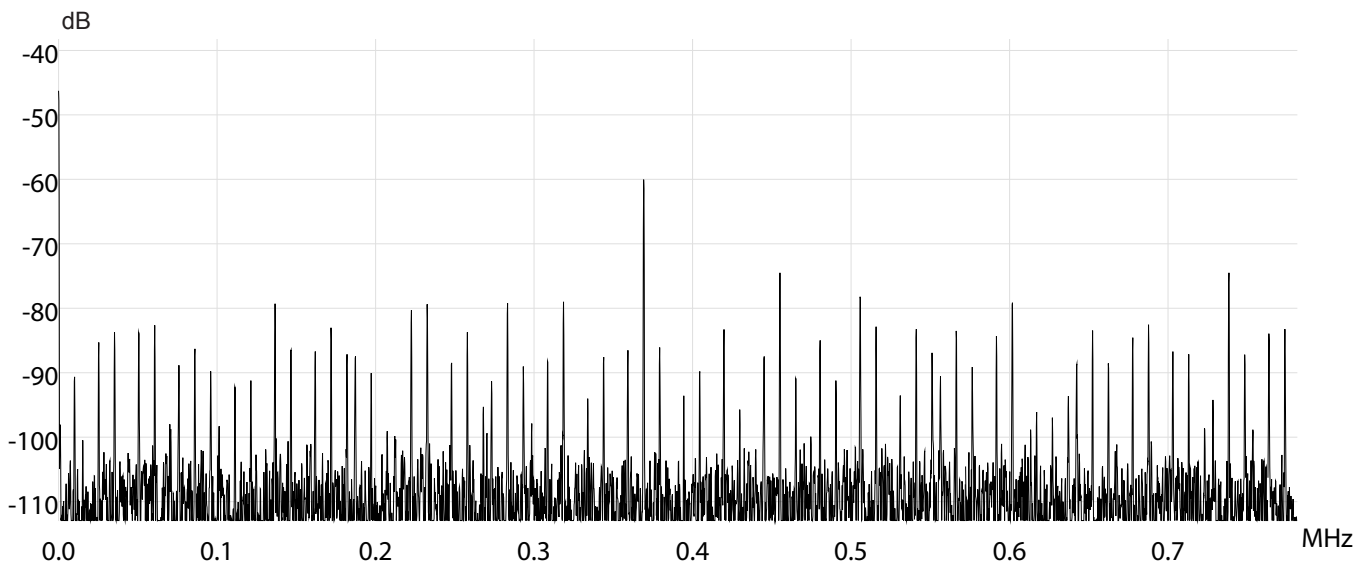

FIGURE 13B. Radiated noise of converter with ungrounded (floating) heat sink (Q75S15/24)

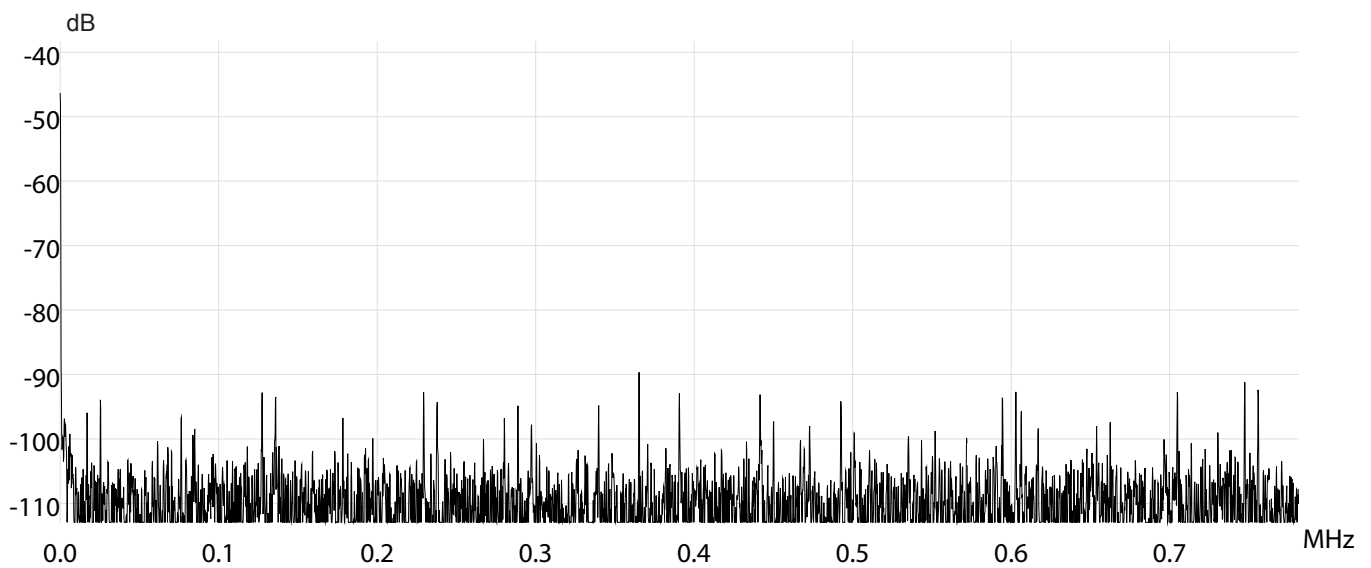

FIGURE 13C. Radiated noise of converter with grounded heat sink (Q75S15/24)