



LOW NOISE EBL30 25-30W DC/DC CONVERTER 2"×1"×0.45"

Key Features

- Efficiency up to 90%
- 10 mV output noise
- Six-sided shielding
- Output synchronous rectification
- Input-to-output isolation
- Soft start
- External synchronization
- Short circuit protection
- Thermal protection
- Industry standard pinout
- Meet FCC class B conducted noise specification



Beta Dyne is protected under various patents, including but not limited to U.S. Patent numbers: 5,777,519; 6,188,276; 6,262,901; 6,452,818; 6,473,3171.

Functional Description

The EBL series is a 30W low noise isolated converter, consisting 15 standard single output models from 2.5 VDC to 15 VDC and 2:1 input voltage range from 9V to 72V. Output synchronous rectification followed by a very low dropout linear regulator made possible to achieve up to 90% efficiency and less than 10mV output noise. Standard features include input undervoltage protection , external synchronization and thermal protection. The converter is packaged in a 1 x 2 x .45" metal case with six-sided shielding. With external components, the converter will meet FCC Class B radiated and conducted noise and 2mV output ripple .

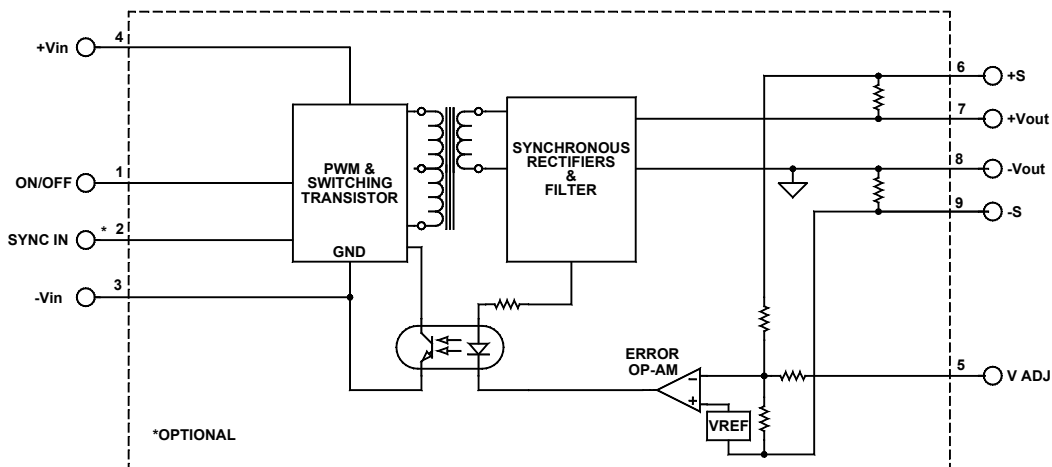

Typical Block Diagram

Unless otherwise specified, all parameters are given under typical ambient temperature of +25°C with an airflow rate = 400LFM. With the given power derating, the operating range is -40°C to +125°C. Specifications subject to change without notice.

Electrical Specifications

INPUT SPECIFICATIONS

PARAMETER	CONDITION / NOTE	MIN	TYP	MAX	UNIT
Input Voltage Range	See model selection guide				Vdc
Input Startup Voltage 12 V _{IN}		8		9	Vdc
Input Startup Voltage 24 V _{IN}				17	Vdc
Input Startup Voltage 48 V _{IN}				35	Vdc
Undervoltage Shutdown 12 V _{IN}		7			Vdc
Undervoltage Shutdown 24 V _{IN}		16			Vdc
Undervoltage Shutdown 48 V _{IN}		32			Vdc
Input Filter	LC				
No Load Input Current	See model selection guide				mA
Full Load Input Current	See model selection guide				A
Input Surge Current (20µs Spike)				10	A
Short Circuit Current Limit	120% Of I _{IN} @ Full Load				
Off State Current			150		µA
Remote ON/OFF Control					
Supply ON	Pin 3 Open (Open circuit voltage: 10V Max.)				
Supply OFF		0		0.6	Vdc
Logic Input Reference					
Logic Compatibility	TTL Open Collector or CMOS Open Drain				

OUTPUT SPECIFICATIONS

PARAMETER	CONDITION / NOTE	MIN	TYP	MAX	UNIT
Voltage	See model selection guide				Vdc
Output Voltage Accuracy			1		%
Output Current	See model selection guide				A
Output Voltage Adjustment	see Figure 10		±5	±10	%
Ripple & Noise	For further reduction see figure 9		40		mV
Line Regulation	Minimum V _{IN} to maximum V _{IN}		±0.04	±0.1	%
Load Regulation	NL to FL		±0.05	±0.1	%
Temperature Coefficient @ FL			1	2	%/°C
Transient Response Time	50% FL to FL to 50% FL, See Figure 4	100			µS
Short Circuit Protection	By input current limiting				
Turn On Delay with Soft Start	See Figure 4		30	40	mS
Output Overvoltage Protection	None				

GENERAL SPECIFICATIONS

PARAMETER	CONDITION / NOTE	MIN	TYP	MAX	UNIT
Efficiency (at full power)	See model selection guide				%
Isolation Voltage (1 min.), Input to Output	All models		1500		Vdc
Isolation Resistance			10 ⁹		Ω
Isolation Capacitance			300		pF
Switching Frequency (FC)			160		kHz
External Sync Frequency (Fe)	see figure 6		340		kHz

ENVIRONMENTAL SPECIFICATIONS

PARAMETER	CONDITION / NOTE	MIN	TYP	MAX	UNIT
Operating Temperature Range (Ambient)	Industrial, See Note 2	-40		+71	°C
Storage Temperature Range		-55		+125	°C
Maximum Operating Case Temperature ¹				110	°C
Derating	See Figure 1				
Cooling	See Figure 1				
MTBF	per MIL-HNBK-217F (Ground benign, +25°C)		1.1×10 ⁶		hours
Shielding Connection	- V _{IN} for 12 V _{IN} , 24 V _{IN}				
	+ V _{IN} for 48 V _{IN}				

Model Selection Guide

MODEL NUMBER	INPUT				Reflected Ripple ⁶ (mA _{pp})	OUTPUT		
	Voltage (Vdc)		Current (mA)			Voltage (Vdc)	Current (mA)	Efficiency Full Load (%)
	Nominal	Range	No Load	Full Load				
EBL30S2.5/12	12	9-18	120	2649	40	2.5	10000	78
EBL30S3.3/12	12	9-18	100	2540	40	3.3	7500	81
EBL30S5/12	12	9-18	130	2443	40	5	5000	85
EBL30S12/12	12	9-18	160	2321	40	12	2000	86
EBL30S15/12	12	18-36	130	2375	40	15	1660	87
EBL30S2.5/24	24	18-36	29	1561	15	2.5	12000	80
EBL30S3.3/24	24	18-36	58	1478	15	3.3	9000	83
EBL30S5/24	24	18-36	64	1429	15	5	6000	87
EBL30S12/24	24	18-36	65	1407	15	12	2500	89
EBL30S15/24	24	18-36	64	1389	15	15	2000	90
EBL30S2.5/48	48	36-72	20	761	10	2.5	12000	82
EBL30S3.3/48	48	36-72	29	745	10	3.3	9000	83
EBL30S5/48	48	36-72	27	712	10	5	6000	88
EBL30S12/48	48	36-72	36	704	10	12	2500	88
EBL30S15/48	48	36-72	34	706	10	15	2000	88

¹ When converter enters thermal protect on mode , its duty cycle is reduced momentarily and will resume after its internal temperature (pwm) drops down a few degrees (°C).The converter's output behave similar to hiccup short circuit mode.

² Contact factory for -55° to +85°C operating temperature range.

³ The maximum input current at any given input range measured at minimum input voltage is given as 1.6*I_{NOMINAL}. Nominal input current is the typical value measured at the input of the converter under full-load room temperature and nominal input voltage (5, 12, 24 and 48V_{IN}).

⁴ Adequate insulation is to be provided to the converters at the end usage as per applicable requirements.

⁵ Temperature rise on the case of the converters is to be considered during the end usage as per applicable requirements.

⁶ For reflected input ripple measurements ,with Cin=100µf and Lin=2.2µH on the input of the converters.

ORDERING GUIDE

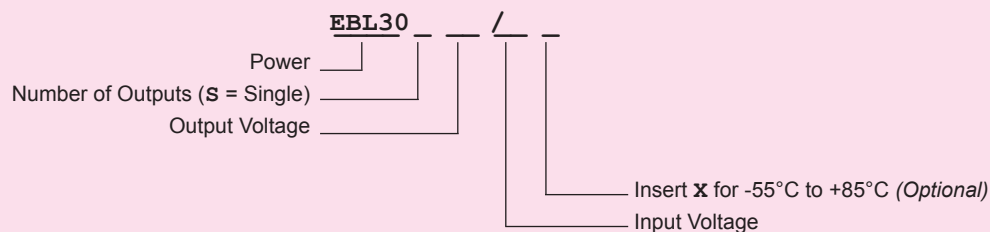

Contact factory for custom input and output voltage combinations

PHYSICAL CHARACTERISTICS

PARAMETER	CONDITION / NOTE	MIN	TYP	MAX	UNIT
Dimensions (L×W×H)	2.00×1.00×0.450 in. (50.80×25.40×11.43mm)				
Weight	1.3 oz. (37g)				

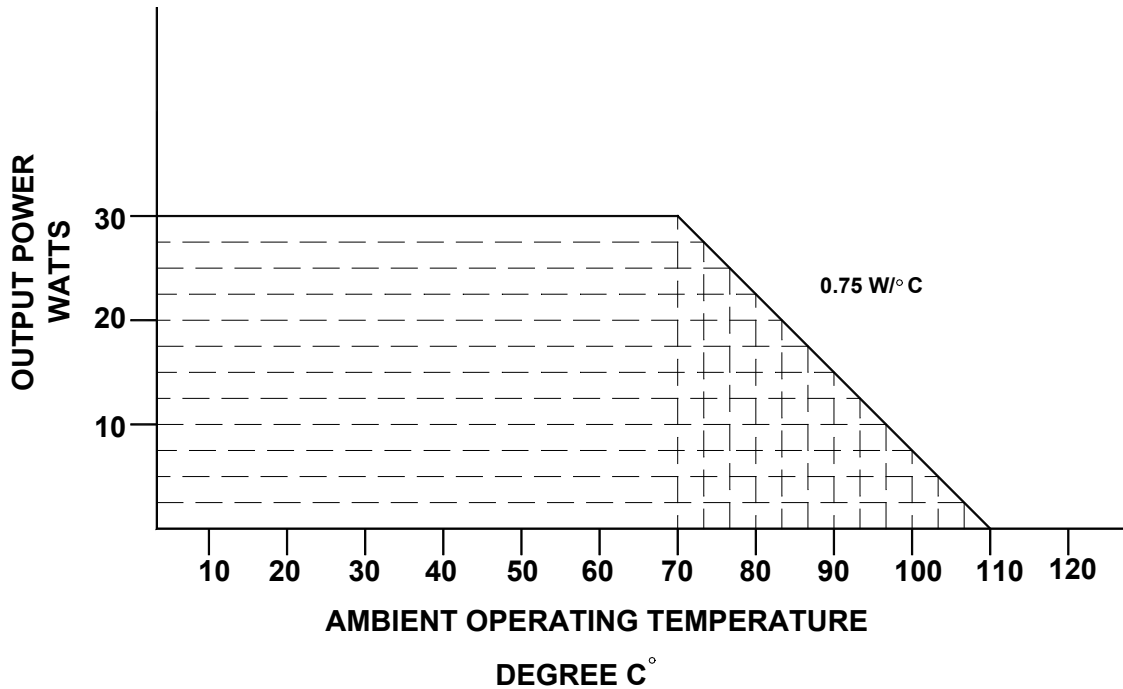

FIGURE 1. Worst case derating for the EBL series

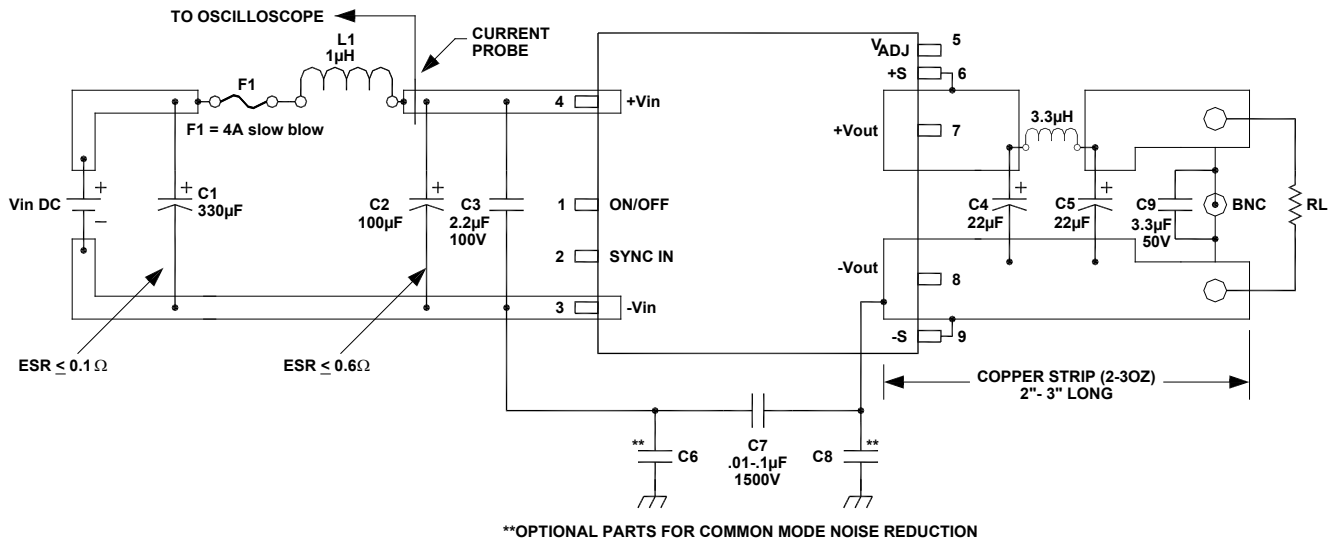

FIGURE 2:

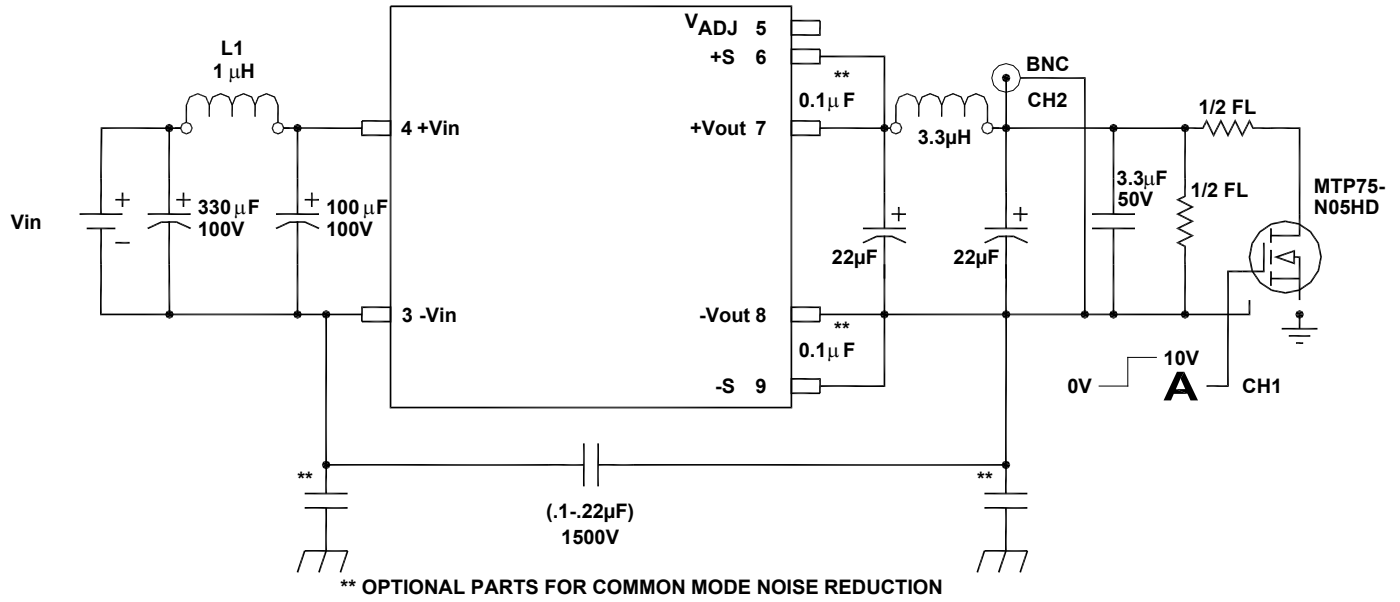

FIGURE 3. Setup for transient response measurements

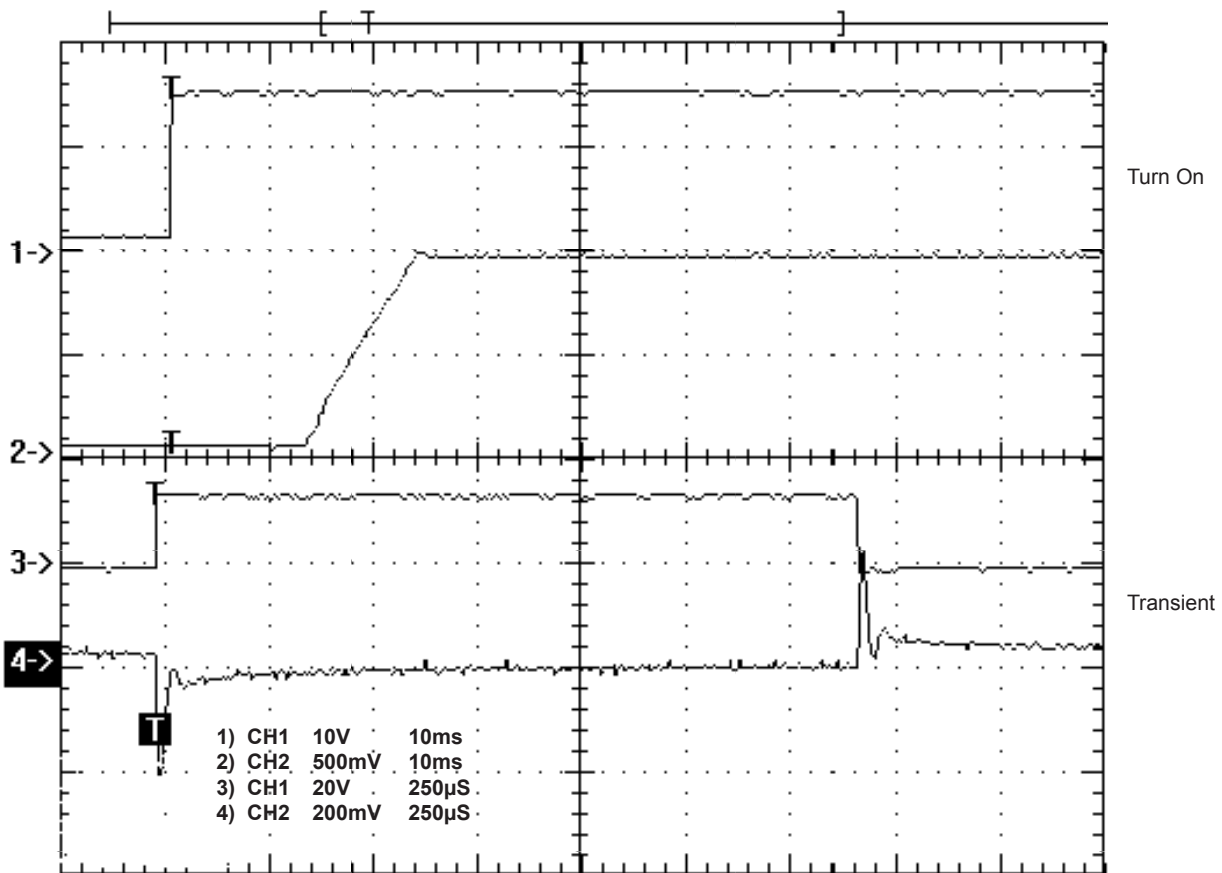

FIGURE 4. Turn on delay with soft start; Transient response 50% full load to full load to 50% full load

EXTERNAL SYNCHRONIZATION

The converter can be synchronized to an external clock. The external clock MUST have a higher frequency than that of the converter's switching frequency. The amplitude of the external clock pulse must be 3.7 volts or greater and its duration between 15nS to 150nS for sync pulse detection.

The circuit in Figure 4 can be used to produce a 50nS to 150nS pulse from a square wave. The circuit will be turned on by the negative edge of the square wave and will stay on for approximately 50nS (depending on the $R2 \cdot C1$ time constant) (See Figure 5).

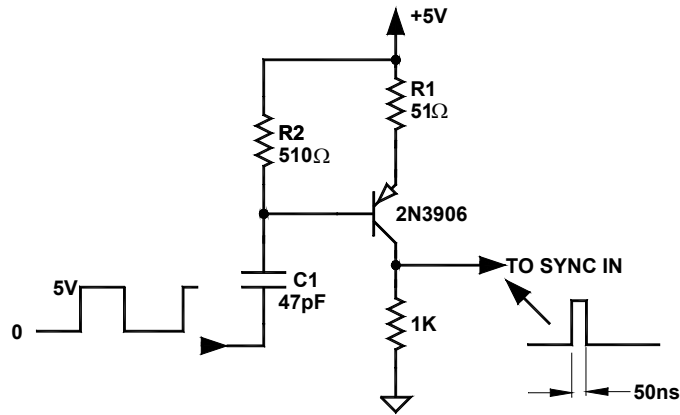

FIGURE 5. 50nS pulse generator from a square wave TTL/5V CMOS clock

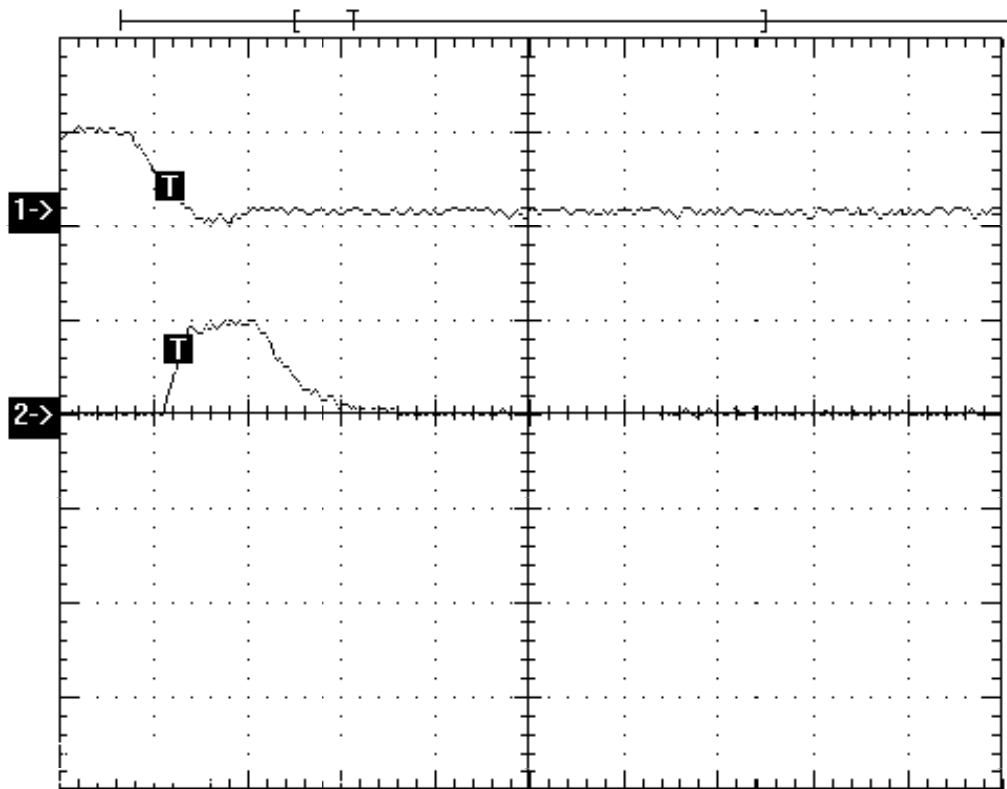

FIGURE 6. Waveforms generated from circuit in Figure 4

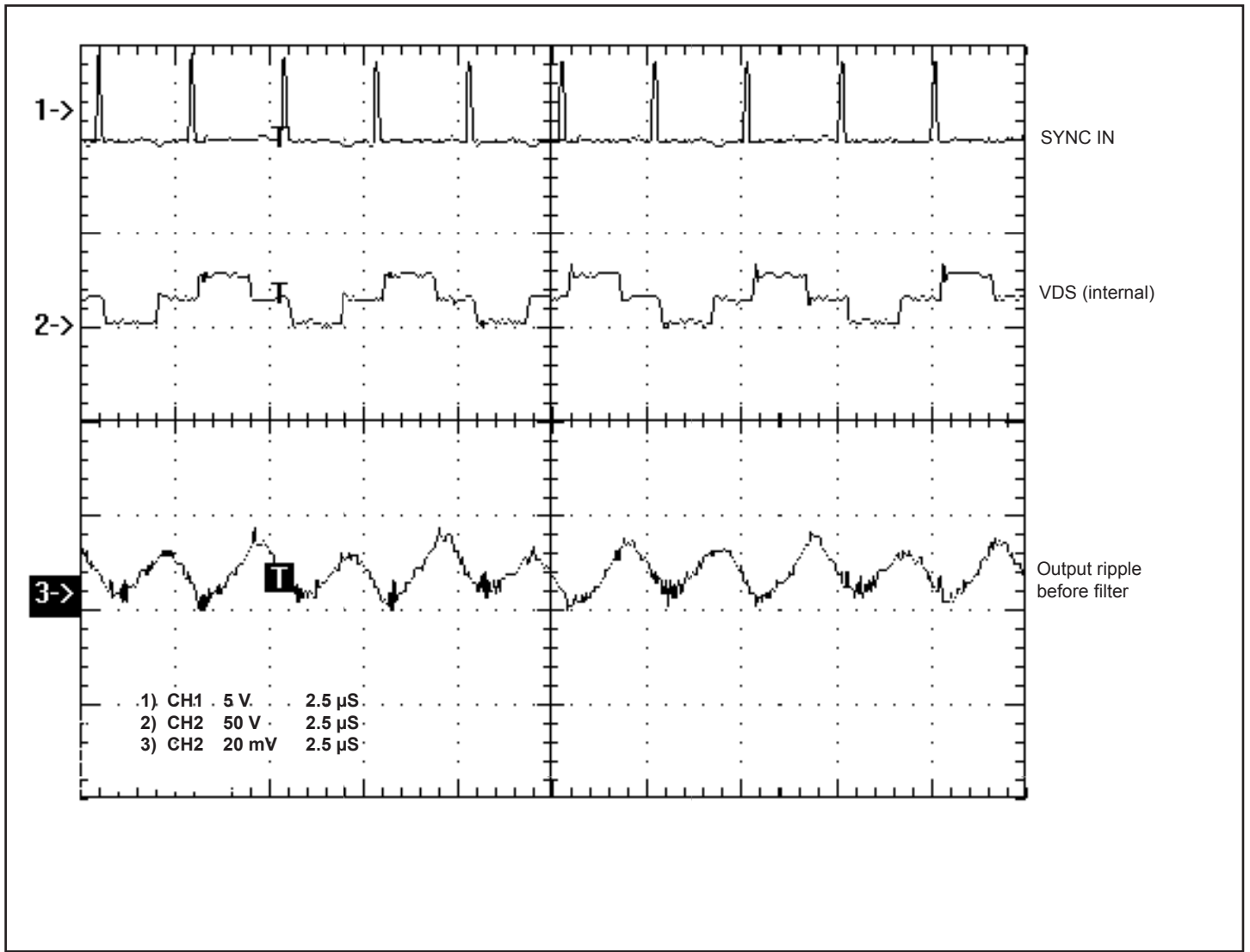
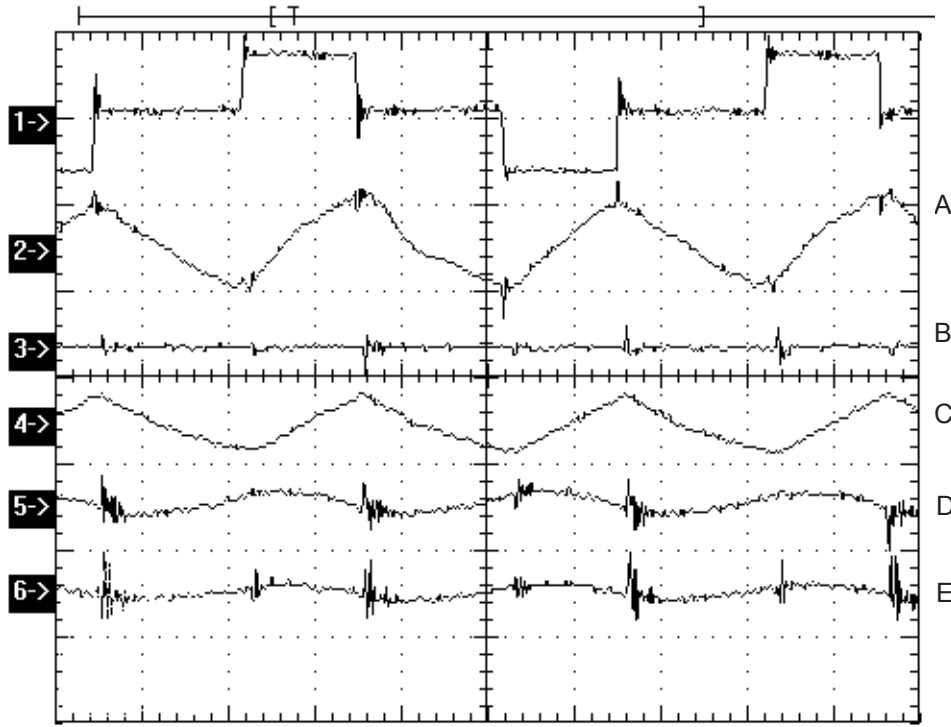

FIGURE 7. External Synchronization



- 1) [SCOPE 1].CH2 20 V 1 μ S
- 2) [SCOPE 1].CH2 10 mV 1 μ S
- 3) [SCOPE 1].CH2 5mV 1 μ S
- 4) [SCOPE 1].CH2 100 mA/mV 1 μ S
- 5) [SCOPE 1].CH2 5 mA/mV 1 μ S
- 4) [SCOPE 1].CH2 5 mA/mV 1 μ S

FIGURE 8: waveforms utilizing the circuit in Figure 9.

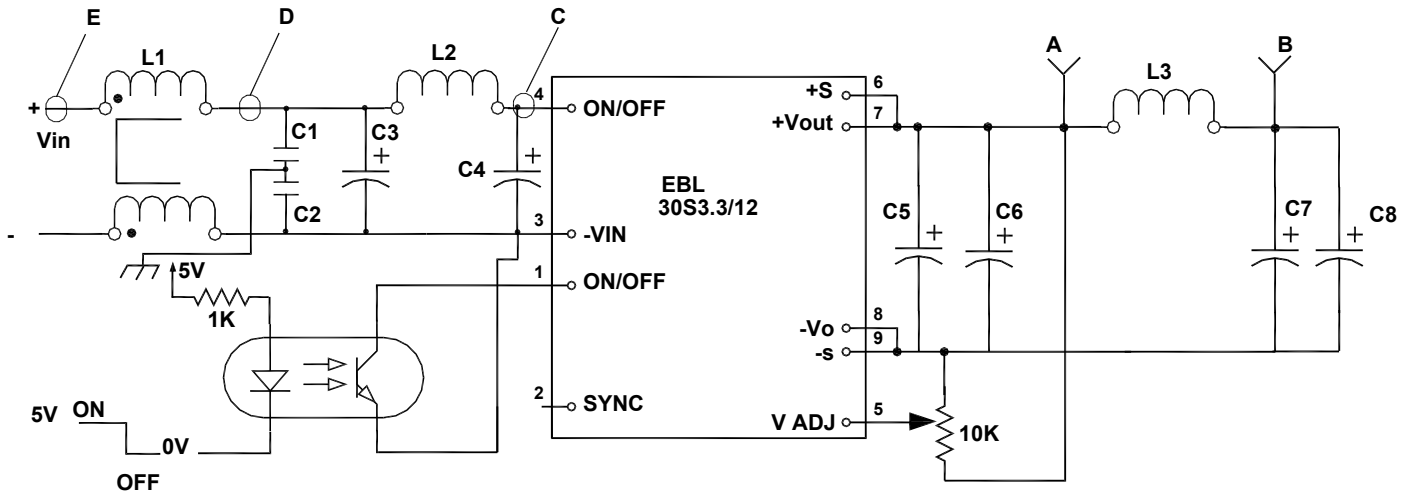
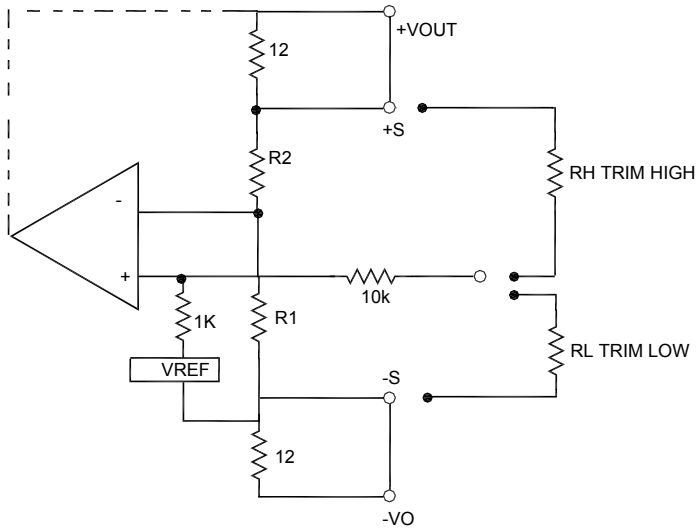

FIGURE 9: Shows the required additional component for 2mV output ripple and input reflected ripple to meet FCC Class B conducted noise .See waveforms in Figure 8

- Part list:
- L1= .77mH P0422 pulse Engineering part # P0422
 - L2=2.2 μ H
 - L3=3.0 μ H
 - C1=C2= 2.2 μ F
 - C3=C4=C5=C7=180 μ F NIPPON - CHEMI - CON Part #(16PS180MH11)
 - C6=C8= 10 μ F CERAMIC capacitors



$$R_H = \frac{R_2}{R_1} \cdot \frac{1 - \frac{V_{REF}}{V_o}}{\left(\frac{R_1 + R_2}{R_1}\right)} - 10 \quad \text{in } k\Omega$$

$$R_L = \frac{1}{\frac{V_{REF}(R_1 + R_2)}{V_o R_1} - 1} - 10 \quad \text{in } k\Omega$$

VO	VREF	R2	R1
2.5V	1.225	2.55K	2.49K
3.3V	1.225	4.22K	2.49K
5V	2.5	2.49K	2.49K
12V	2.5	9.53K	2.49K
15V	2.5	15K	3.01K

FIGURE :10 Output adjustment equations

MECHANICAL SPECIFICATIONS

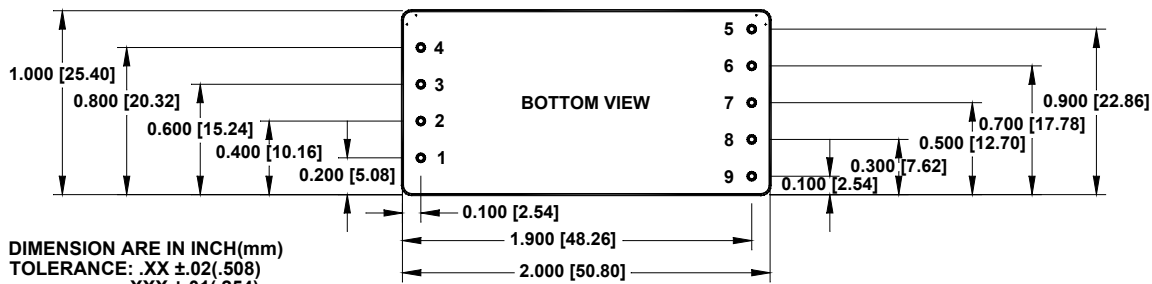
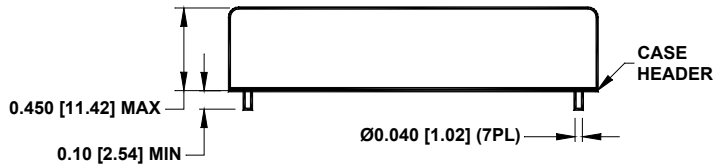

Pin	Function
INPUT	
1	ON/OFF
2	SYNC IN*
3	-V _{IN}
4	+V _{IN}
OUTPUT	
5	V _{ADJ}
6	+S
7	+V _{OUT}
8	-V _{OUT}
9	-S