



EAL50

50W SINGLE LOW-NOISE DC/DC CONVERTERS

$9V_{IN}$ to $72V_{IN}$, $3.3V_{OUT}$ to $15V_{OUT}$

Key Features

- High efficiency up to 93%
- Output overvoltage protection (OVP)
- 2:1 input voltage range
- Six-sided shielding
- Soft start
- 1500Vdc input-to-output isolation
- Short circuit and thermal protection
- Adjustable output
- 300 μ A off state current
- Output synchronous rectification
- Input undervoltage protection



Beta Dyne is protected under various patents, including but not limited to U.S. Patent numbers: 5,777,519; 6,188,276; 6,262,901; 6,452,818; 6,473,3171.

Functional Description

The EAL50 is a series of 50W low-noise isolated single output DC/DC converters based on patented technology for synchronous rectification, followed by a very low dropout linear regulator made possible to achieve low output noise. The converters offer a power output up to 50W, a 2:1 input voltage range from $9V_{IN}$ to $72V_{IN}$ and an output voltage from $3.3V_{OUT}$ to $15V_{OUT}$. Other standard features include input undervoltage protection, thermal protection, external synchronization, and six-sided shielding.

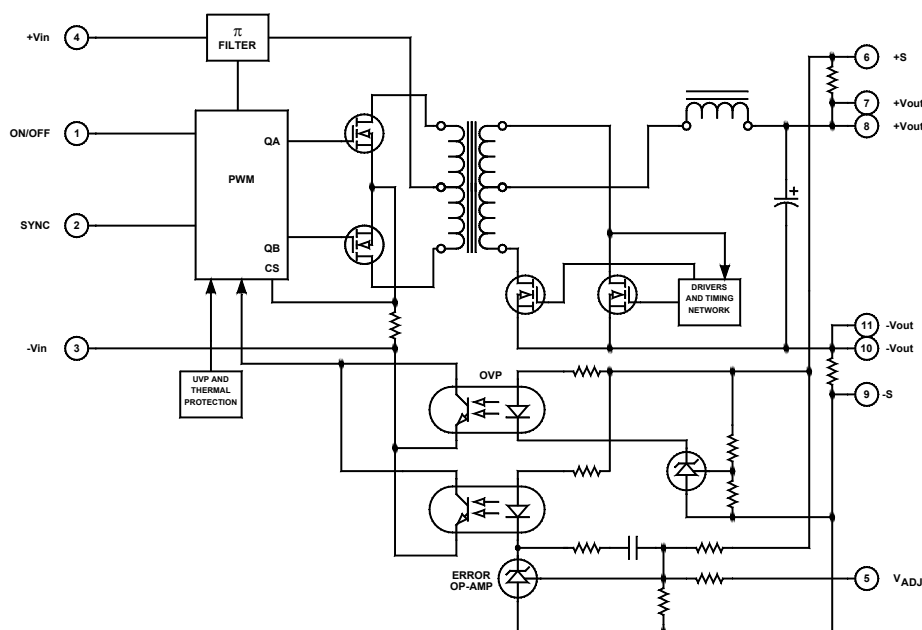

Typical Block Diagram

Electrical Specifications

INPUT SPECIFICATIONS

Unless otherwise specified, all parameters are given under typical +25°C with nominal input voltage and under full output load conditions.

PARAMETER	CONDITION / NOTE	MIN	TYP	MAX	UNIT
Input Voltage Range	See Model Selection Guide				
Input Filter					
Reverse Polarity Input Current	External series-blocking diode			12	A
Input Surge Current (20µS Spike)				10	A
No Load Input Current	See Model Selection Guide				
Full Load Input Current	See Model Selection Guide				
Short Circuit Current Limit			125		% I _{IN}
Undervoltage Shutdown, 5V	Contact factory		4.7		Vdc
Undervoltage Shutdown, 12V			7.5		Vdc
Undervoltage Shutdown, 24V			17.5		Vdc
Undervoltage Shutdown, 48V			33		Vdc
Off State Current			300		µA
Remote ON/OFF Control					
Converter ON	Open (Open circuit voltage at Pin 1: 10V Max.)				
Converter OFF		-0.6	0	0.2	Vdc
Logic Input Reference	-Input				
Logic Compatibility	TTL Open Collector or CMOS Open Drain				
Sync Input	TTL	2.5		5	Vdc
Sync Input Frequency Range		310	320	360	kHz
Sync Input Minimum Pulse Width	See Figure 4	200			nS

OUTPUT SPECIFICATIONS

PARAMETER	CONDITION / NOTE	MIN	TYP	MAX	UNIT
Output Voltage	See Model Selection Guide				
Output Current	See Model Selection Guide				
Output Voltage Accuracy			±1	±2.0	%
Output Voltage Adjustment			3	±5	%
Minimum Load	None Required				% of FL
Ripple & Noise	see Note 5		15		mV
Line Regulation	Minimum V _{IN} to maximum V _{IN}		±1	±2	%
Load Regulation	NL to FL		±1	±2	%
Temperature Coefficient @ FL			0.02		%/°C
Transient Response Time (to within 1% of V _{OUT})	50% FL to FL to 50% FL, See Figure 3		50		µS
Short Circuit Protection	By input current limiting				

GENERAL SPECIFICATIONS

PARAMETER	CONDITION / NOTE	MIN	TYP	MAX	UNIT
Efficiency	See Model Selection Guide				
Isolation Voltage (1 min.)			1500		Vdc
Isolation Resistance			10 ⁹		Ω
Isolation Capacitance			80		pF
Switching Frequency			150		kHz

ENVIRONMENTAL SPECIFICATIONS

PARAMETER	CONDITION / NOTE	MIN	TYP	MAX	UNIT
Operating Temperature, Industrial (Ambient)	See Figure 2, see Note 2	-40		+75	°C
Storage Temperature Range		-55		+125	°C
Thermal Resistance			2.25	2.50	°C/W _{DISS}
Maximum Operating Case Temperature				105	°C
Thermal Turn Off, Case Temperature		90	100	105	°C
Thermal Hysteresis			10		°C
Derating	See Figure 2				
Humidity	Up to 95% non-condensing				
Cooling	Free-air convection				
EMI/RFI	Six-sided continuous shielded metal case				
MTBF	per MIL-HNBK-217F (Ground benign, +25°C)		625,000		hours

PHYSICAL CHARACTERISTICS

PARAMETER	CONDITION / NOTE	MIN	TYP	MAX	UNIT
Dimensions (L×W×H)	2.00×2.00×0.50 in. (50.80×50.80×12.70mm)				
Weight	2.78 oz. (79g)				
Case Material	Coated metal				
Shielding Connection 12, 24V _{IN}	-V _{IN} (Pin 3)				
Shielding Connection 48,	+V _{in} (Pin 4)				

Notes

- 1: Measured with C1=50µF (See Fig 1)
2. Contact Factory for -55 to +85 C operating temperature range
3. Adequate insulation is to be provided to the converters at the end usage as per applicable requirements.
4. Temperature rise on the case of the converters is to be considered during the end usage as per applicable requirements.
5. Output ripple is measured with two tantalum 220µF@10V and 10µF@25V ceramics in parallel on the output as shown in Figure 1.

MECHANICAL SPECIFICATIONS

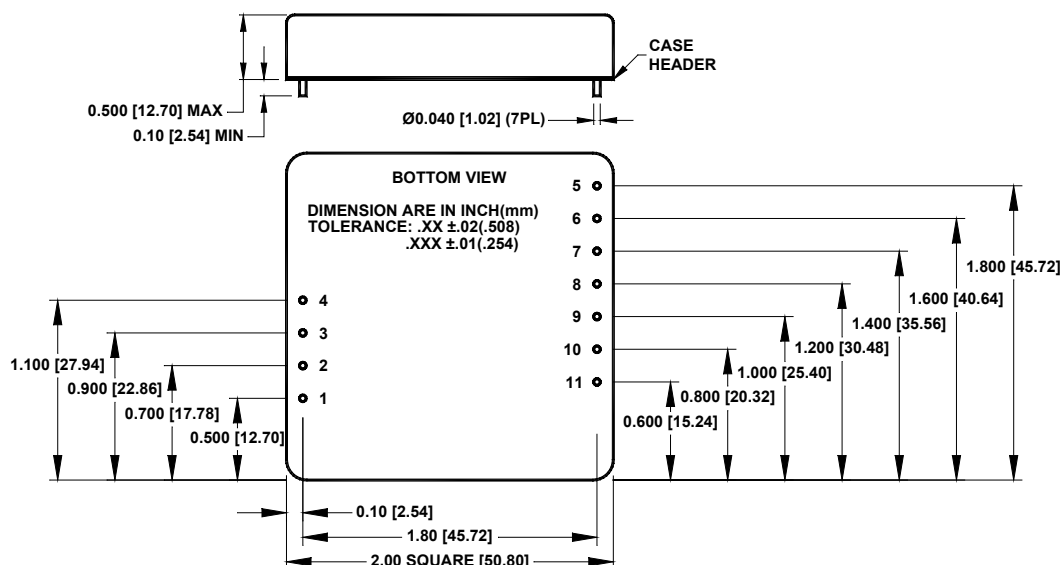

Pin	Function
	SINGLE
1	ON/OFF
2	SYNC
3	-V _{IN}
4	+V _{IN}
5	V _{OUT} ADJ
6	+SENSE
7	+V _{OUT}
8	+V _{OUT}
9	-SENSE
10	-V _{OUT}
11	-V _{OUT}

Model Selection Guide

MODEL NUMBER	INPUT				OUTPUT		
	Voltage (Vdc)		Current (mA)		Voltage (Vdc)	Current (mA)	Efficiency Full Load (%)
	Nominal	Range	No Load	Full Load			
EAL50S3.3/12	12	9-18	125	3970	3.3	12000	84
EAL50S5/12	12	9-18	130	3935	5	8000	85
EAL50S12/12	12	9-18	80	4758	12	4166	88
EAL50S15/12	12	9-18	160	4727	15	3333	88
EAL50S3.3/24	24	18-36	77	1975	3.3	12000	84
EAL50S5/24	24	18-36	77	2378	5	10000	88
EAL50S12/24	24	18-36	77	2271	12	4166	93
EAL50S15/24	24	18-36	100	2289	15	3333	91
EAL50S3.3/48	48	36-72	150	998	3.3	12000	83
EAL50S5/48	48	36-72	200	1206	5	10000	87
EAL50S12/48	48	36-72	50	1167	12	4166	90
EAL50S15/48	48	36-72	33	1138	15	3333	91

Contact factory for custom input and output voltage combinations

ORDERING GUIDE

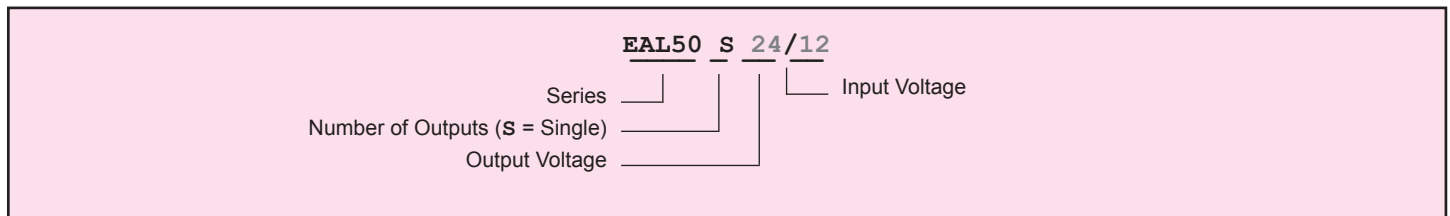

EXTERNAL TRIMMING OF OUTPUT VOLTAGES

To trim the output voltage UP, connect a 5% ¼W resistor between the +V_{O1} output and trim pin of the converter. To trim the output voltage DOWN, connect a 5% ¼W resistor between the -V_{O1} output and trim pins of the converter. For UP/DOWN trimming capability, connect a 10kΩ potentiometer between the + and - output pins, with the wiper arm connected to the trim pin.

The trim resistors/potentiometer can be connected at the converter output pins or the load. However, if connected at the load, the resistance of the runs becomes part of the feedback network which improves load regulation. If load is some distance from the converter, the use of #20 gauge wire is recommended to avoid excessive voltage drop due to the resistance of the circuit paths.

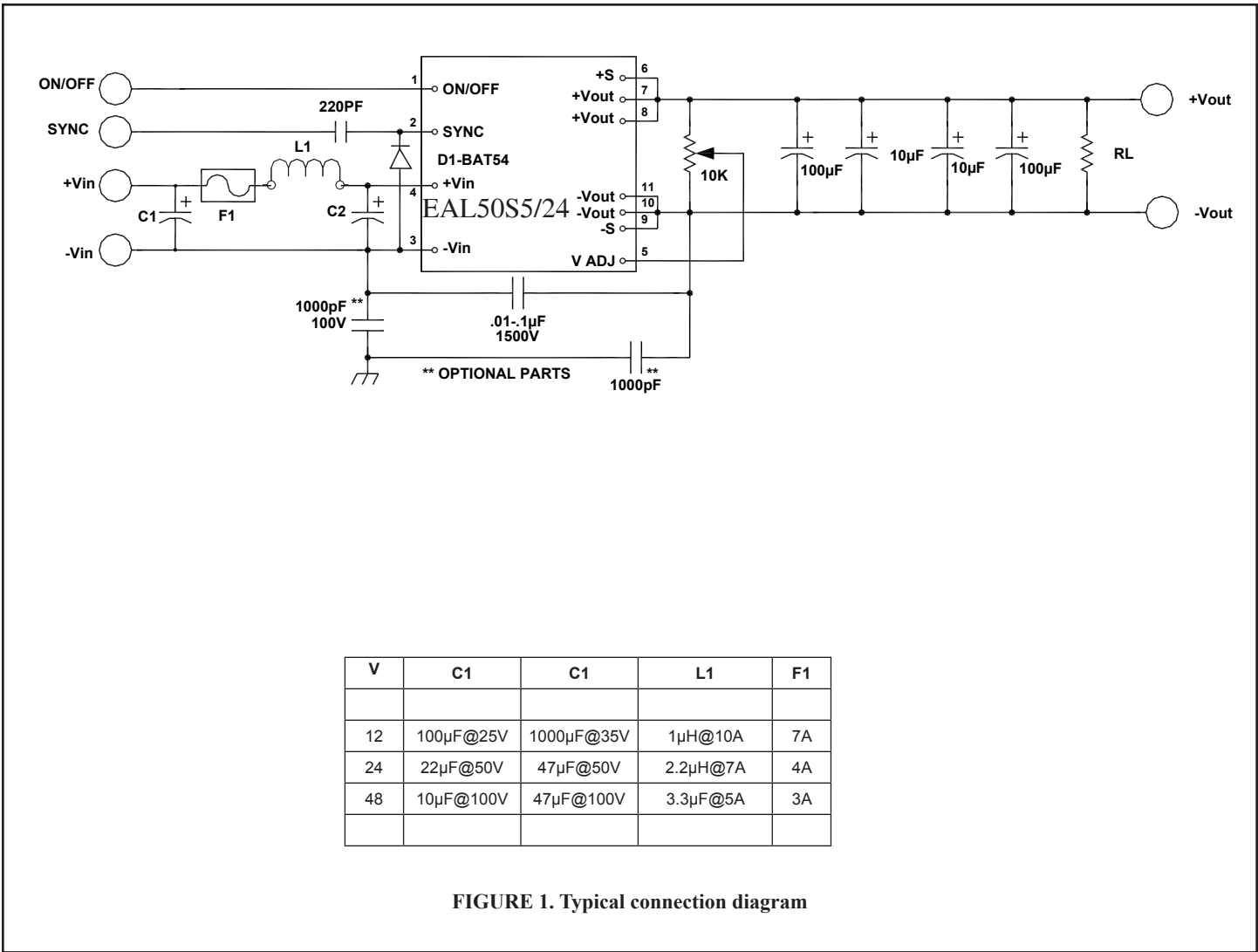

FIGURE 1. Typical connection diagram

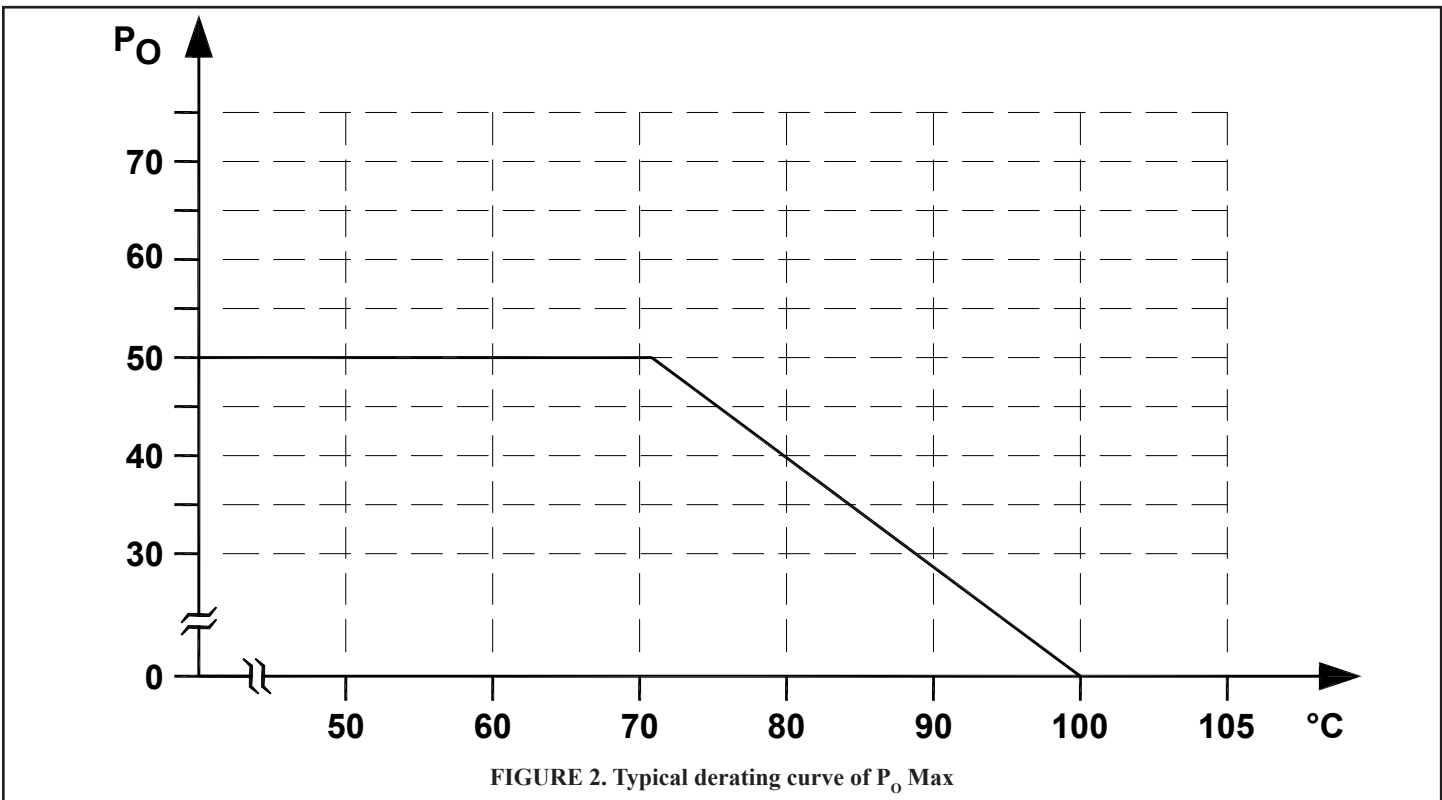

FIGURE 2. Typical derating curve of P_o Max

EXTERNAL SYNCHRONIZATION

The converter can be synchronized to an external clock by driving the SYNC pin (pin 2) directly. The driving signal frequency must be 330kHz \pm 5% (200nS to 300nS negative going pulse (See Figure 4, Waveform 1)). When the external clock is AC-coupled to the SYNC pin of the converter through a ceramic capacitor, connect

a signal Schotky diode with the cathode connected to the SYNC pin and the anode to $-V_{IN}$ (See Figure 1). AC coupling reduces the power required for driving multiple converters and allows for continuous operation of the other synchronized converters in case the driving signal is missing or a short circuit develops at one of the sync inputs.

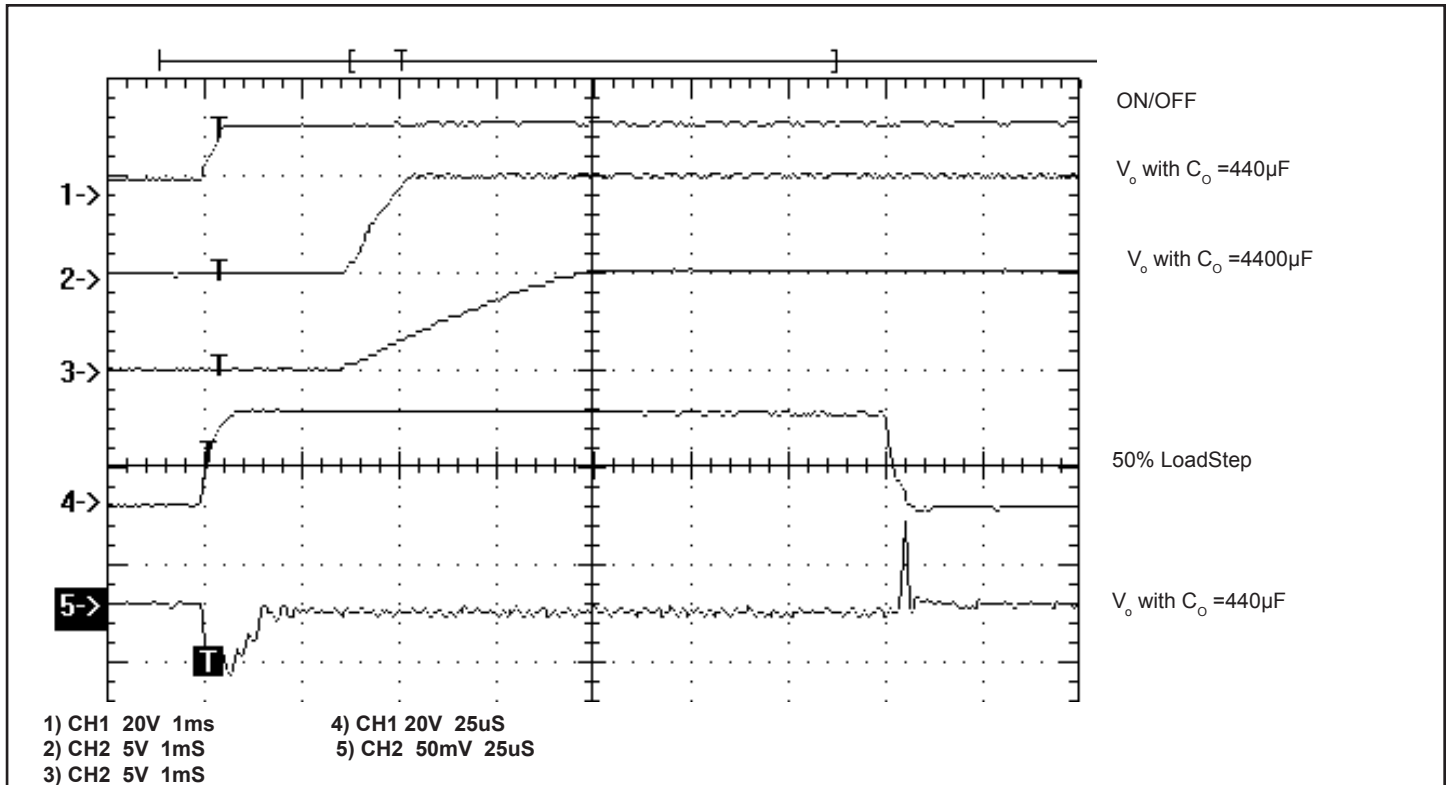

FIGURE 3. EAL50S5/24 Turn on delay with soft start and transient response

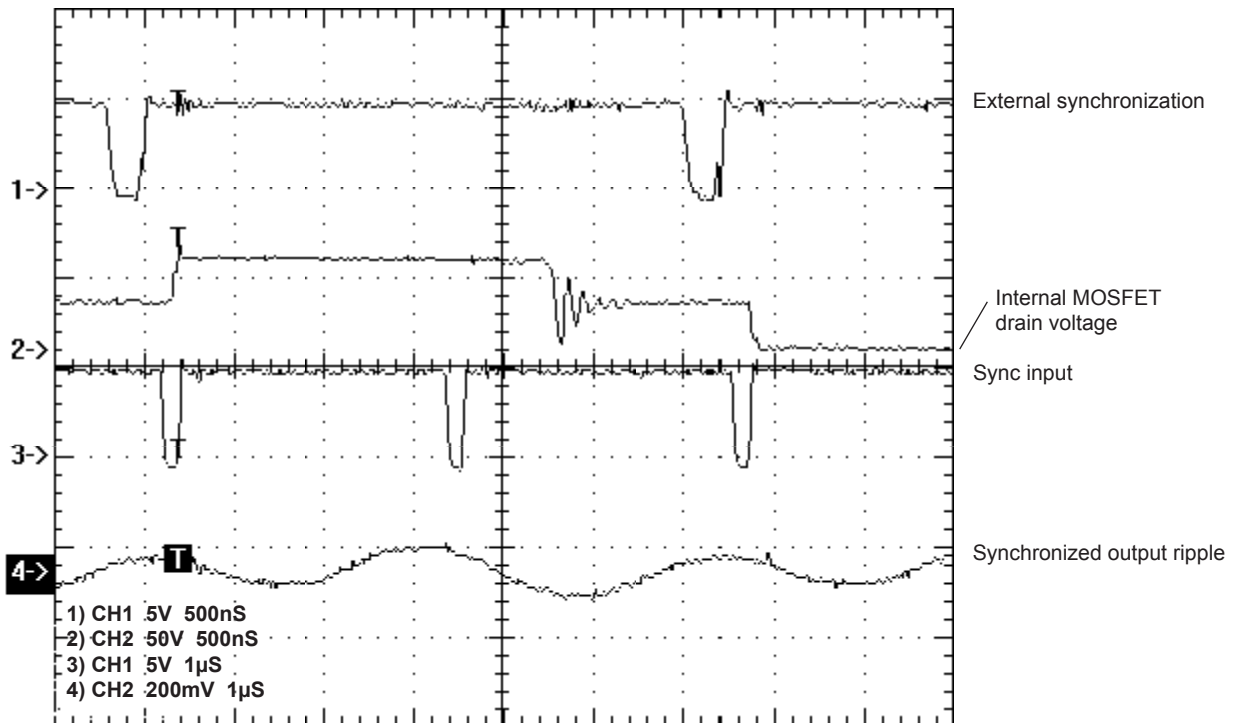

FIGURE 4. Synchronization waveforms