



AHV50

50W HIGH-VOLTAGE ADJUSTABLE DC/DC CONVERTER

0 to 700Vdc Single Output, 0 to ± 350 Vdc

Key Features

- Efficiency up to 88%
- Wide input voltage range (2:1)
- Six-sided shielding
- Soft start
- Single/Dual/Triple
- Short circuit and thermal protection
- Adjustable output

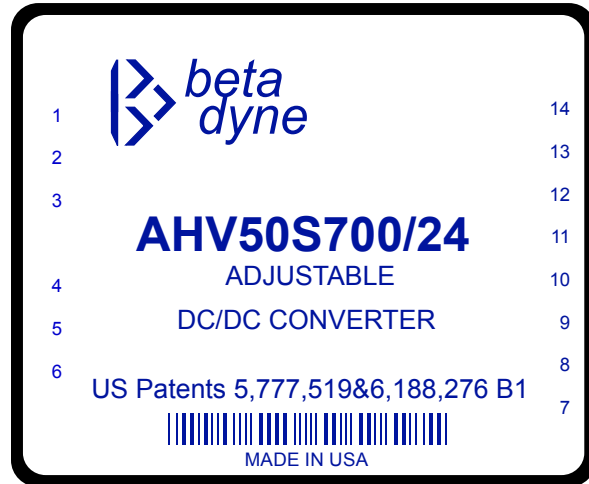

Beta Dyne is protected under various patents, including but not limited to U.S. Patent numbers: 5,777,519; 6,188,276; 6,262,901; 6,452,818; 6,473,3171.

Applications

- High Voltage Programable
- Voltage Source
- Instrumentation
- Test & Measurement
- Telecom

Functional Description

The high voltage adjustable AHV50 series DC/DC converters. The AHV50 series is a 50W multiple output adjustable converter with output voltage range from 5V to +700V or ± 5 V to ± 350 V when is set by the factory as single (unipolar) or dual (bipolar) respectively. It can also be set for 3 isolated adjustable outputs with the main output providing for line and load regulation and two tracking auxiliary output. The output is adjusted either from a 0V to 2.5V or voltage source or a 0-1mA current source. Standard features include 2:1 input voltage range 10-18, 18-36, 36-72, input to output isolation soft start, external synchronization input under/over voltage protection and output over voltage protection. Packaged in a 3x2.5x.75 copper case for EMI/RFI shielding and good thermal performance from -40 to +71°C.

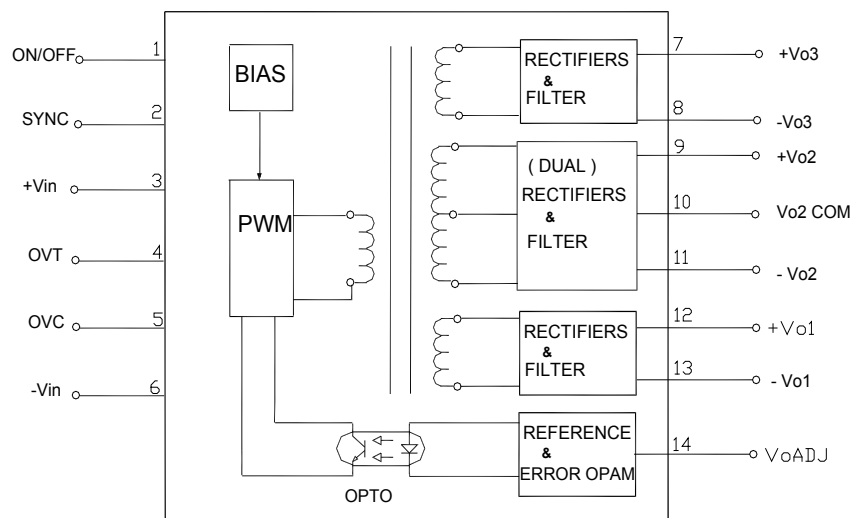

Typical Block Diagram

Unless otherwise specified, all parameters are given under typical +25°C with nominal input voltage and under full output load conditions.

Electrical Specifications

INPUT SPECIFICATIONS

PARAMETER	CONDITION / NOTE	MIN	TYP	MAX	UNIT
Input Voltage Range	See Model Selection Guide				
Startup Voltage for Bias Converter		4.7	5		Vdc
Input Startup Voltage, 12V _{IN}		10.5	11		Vdc
Input Startup Voltage, 24V _{IN}		17	18		Vdc
Input Startup Voltage, 48V _{IN}		35	36		Vdc
Input Startup Voltage, 120V _{IN}		74	75		Vdc
Input Overvoltage Protection, 12V _{IN}		19	20		Vdc
Input Overvoltage Protection, 24V _{IN}		37	38		Vdc
Input Overvoltage Protection, 48V _{IN}		74	76		Vdc
Input Overvoltage Protection, 120V _{IN}		145			Vdc
Input Filter	LC				
Reverse Polarity	Internal parasitic shunt diodes				
Reflected Ripple	I _o = FL, See Model Selection Guide				
No Load Input Current	See Model Selection Guide				
Input Surge Current (20µS Spike)				10	A
Short Circuit Current Limit	See Short Circuit Protection		150		% I _{IN}
Off State Current			750		µA
Remote ON/OFF Control					
Supply ON	Pin 1 Open (Open circuit voltage: 13V max.)				
Supply OFF		-0.6	0	0.8	Vdc
Logic Input Reference	To -V _{IN} for ON/OFF and SYNC				
Logic Compatibility for Reference	TTL Open Collector or CMOS Open Drain				
OVC/OVP Voltage	Open drain voltage			60	Vdc
OVC/OVP Current	Sink		50	100	mA
Sync, High	See External Synchronization, Figures 8 & 9	2		6	Vdc
Sync, Low	See External Synchronization, Figures 8 & 9	0		0.8	Vdc

OUTPUT SPECIFICATIONS

PARAMETER	CONDITION / NOTE	MIN	TYP	MAX	UNIT
Output Voltage	See Model Selection Guide				
Output Voltage Accuracy			±0.5	±1	%
Ripple & Noise			1	2	%
Control Voltage Range V _c		0		2.5	V
V _c Current	Sink / Source			1	mA
Output Current	See Model Selection Guide				
Line Regulation			±1.0	±2.0	%
Temperature Coefficient @ FL			0.02		%/°C
Transient Response Time	50% FL to FL to 50% FL		200	250	µS
Short Circuit Protection	By input current limiting				

GENERAL SPECIFICATIONS

PARAMETER	CONDITION / NOTE	MIN	TYP	MAX	UNIT
Efficiency	See Model Selection Guide				
Isolation Voltage (1 min.), Input to Output			1500		Vdc
Isolation Voltage (1 min.), Output to Output			500		Vdc
Isolation Resistance			10 ⁹		Ω
Isolation Capacitance			2700		pF
Switching Frequency, Power Stage			110		kHz
Switching Frequency, BIAS Stage			330		kHz
Turn On Delay	See Figure 3		12	20	mS
Soft Start Time	See Figure 3		12	20	mS

ENVIRONMENTAL SPECIFICATIONS

PARAMETER	CONDITION / NOTE	MIN	TYP	MAX	UNIT
Operating Temperature, Industrial (Ambient)*	See note in Figures 1,2 & 8	0		+71	°C
Operating Temperature, Extended (X)	See Ordering Guide (Please contact factory)	-55		+85	°C
Storage Temperature Range		-55		+125	°C
Thermal Resistance			1.6		°C/W _{DISS}
Heatsink Thermal Res	See Figure 4 & 8		2.5		°C/W _{DISS}
Maximum Operating Case Temperature				95	°C
Thermal Turn Off, Case Temperature		75	85	95	°C
Thermal Hysterisis			20		°C
Derating					
Humidity	Up to 95% non-condensing				
Cooling	Free-air convection				
EMI/RFI	Six-sided continuous shielded metal case				

* See footnotes 3, 4, 5 and 6

PHYSICAL CHARACTERISTICS

PARAMETER	CONDITION / NOTE	MIN	TYP	MAX	UNIT
Dimensions (L×W×H)	3.00×2.50×0.75 in. (76.20×63.50×19.5mm)				
Weight	7.9 oz. (225g)				
Case Material	Coated metal				
Shielding Connection, 5, 12, 24V _{IN}	-Input (Pin 6)				
Shielding Connection, 48, 120V _{IN}	+Input (Pin 3)				

Model Selection Guide

MODEL NUMBER	INPUT				Reflected Ripple ⁷ (mA _{pp})	OUTPUT		
	Voltage (Vdc)		Current (mA)			Voltage (Vdc)	Current ⁸ (mA)	Efficiency Full Load (%)
	Nominal	Range	No Load	Full Load				
AHV50S700/12	12	9-18	210	3557	150	700	70@700V	82
AHV50S700/24	24	18-36	200	1716	100	700	70@700V	85
AHV50S700/48	48	36-72	200	838	100	700	70@700V	88
AHV50S700/110	110	72-144	150	366	100	700	70@700V	87

Contact factory for custom input and output voltage combinations

¹ ⚠ WARNING - Usage of input fuse with adequate ratings is essential to avoid possible hazard and damage of the unit. A suppressor diode with adequate ratings is intended to be connected in series to the supply for reverse polarity protection.

² Pins 6 and 7 are connected internally.

³ Contact factory for -55° to +85°C operating temperature range.

⁴ The maximum input current at any given input range measured at minimum input voltage is given as $1.6 \times I_{\text{NOMINAL}}$. Nominal input current is the typical value measured at the input of the converter under full-load room temperature and nominal input voltage (5, 12, 24 and 48V_{IN}).

⁵ Adequate insulation is to be provided to the converters at the end usage as per applicable requirements.

⁶ Temperature rise on the case of the converters is to be considered during the end usage as per applicable requirements.

⁷ Measured with 100µF external capacitor at the input pins.

⁸ See Figure 8.

ORDERING GUIDE

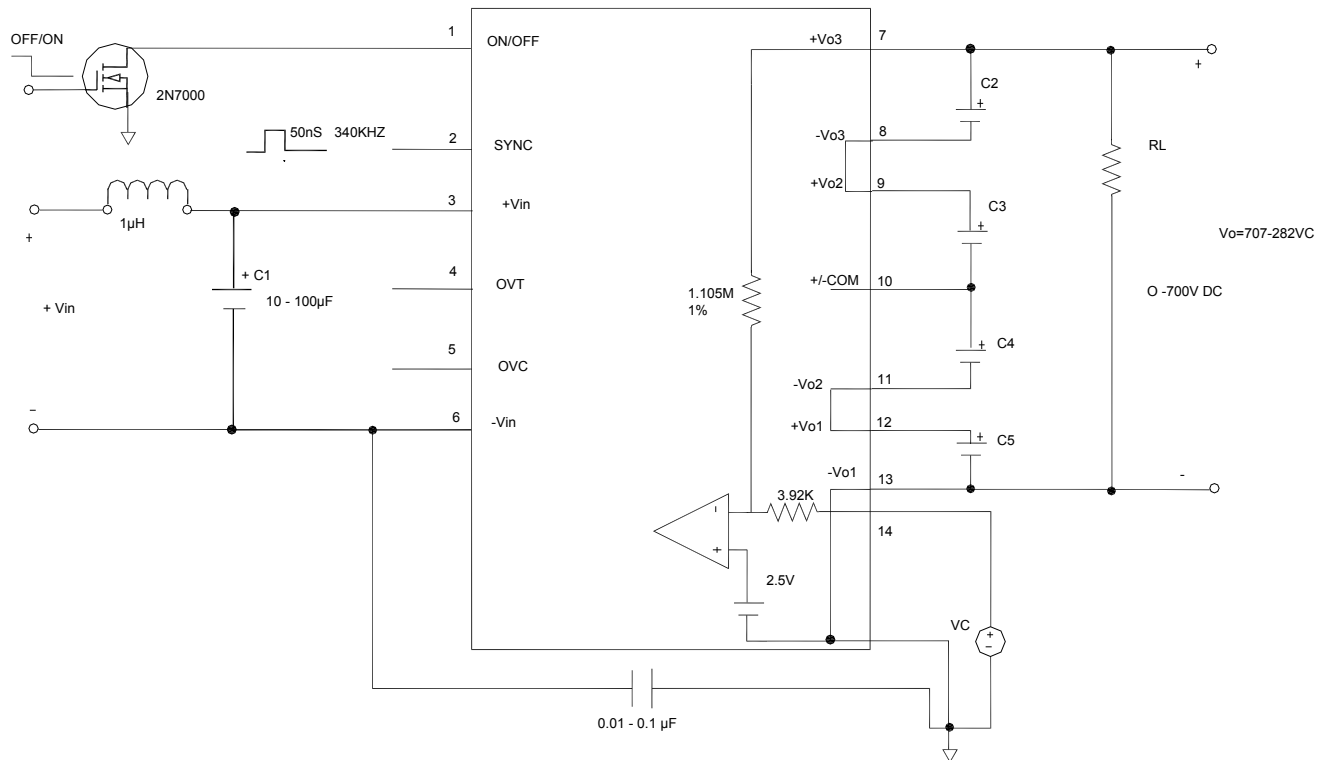
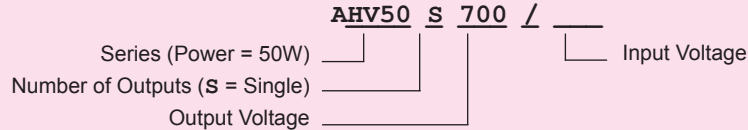

FIGURE 1. Typical Output Diagram Connection of AVH50 Series Single Output 0 to 700V Output

C1 THROUGH C5 = 10µF @200V, VC= 0 TO 2.5V, $V_o = 702.5$ TO 0V, $V_o = (281) 2.5$

NOTE: For -40° Operation C2 Through C5 Must Be 3.3 µF Or Greater @200V X7R Or Y5U Type

Example: Nippon Chemi-Con (TCD51E2E155M)

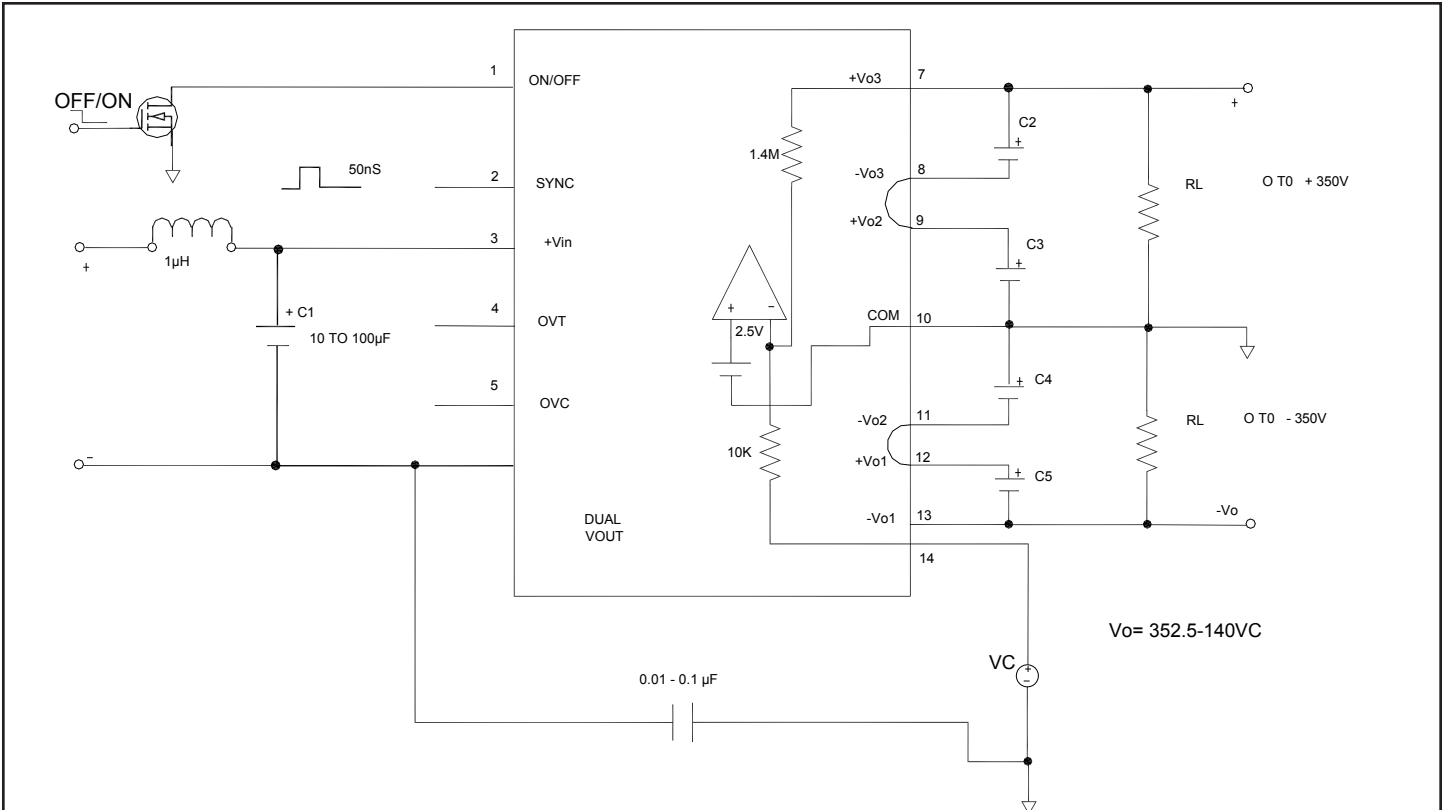

FIGURE 2. Typical Output Diagram Connection of AHV 50 Series Dual Output $\pm 350V$ Max
 $V_C = 0$ TO $2.5V$ $V_{OUT} = 350$ TO $0V$
NOTE: For -40° Operation C2 Through C5 Must Be $3.3 \mu F$ Or Greater @ $200V$ X7R Or Y5U Type
Example: Nippon Chemi-Con (TCD51E2E155M)

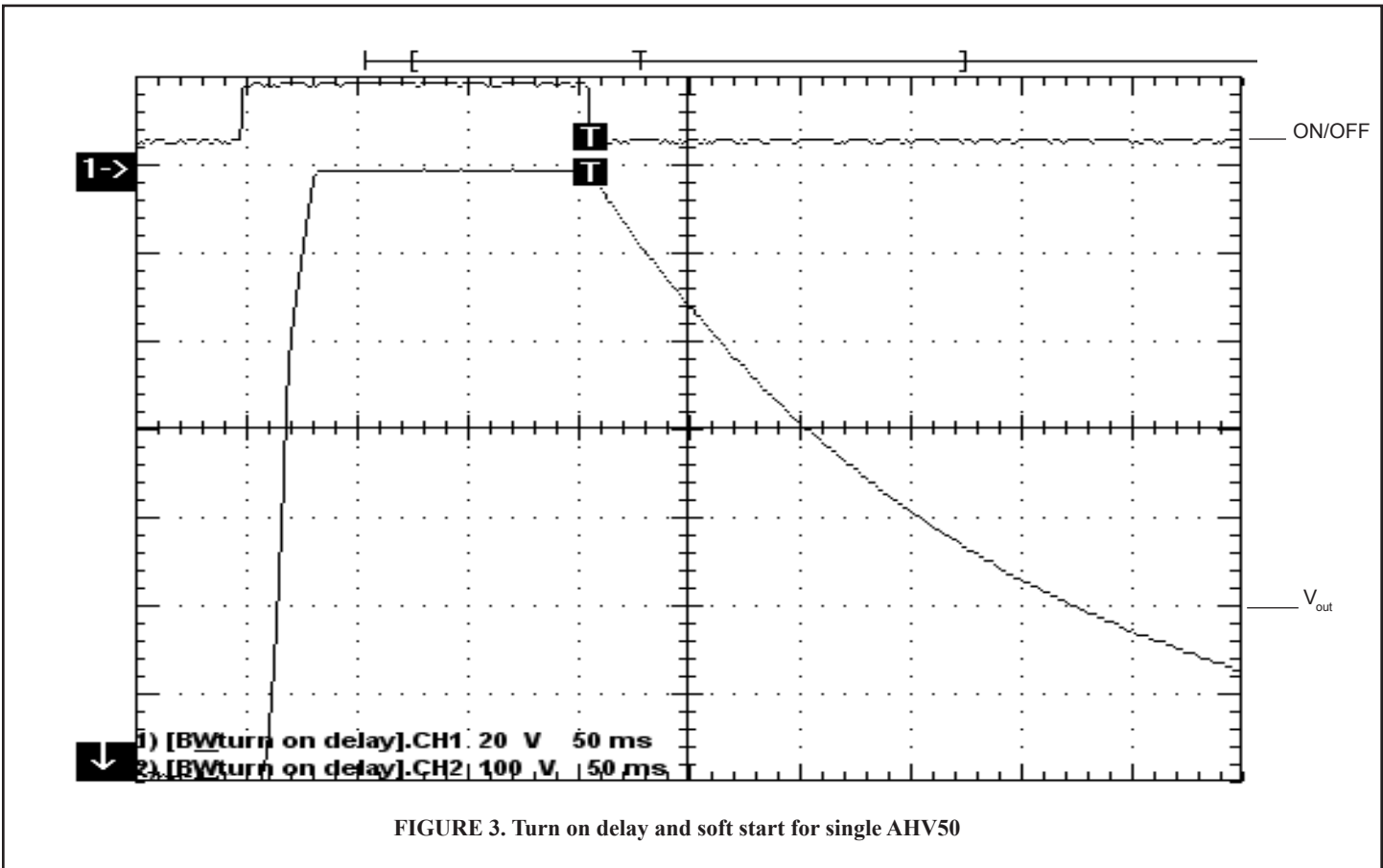
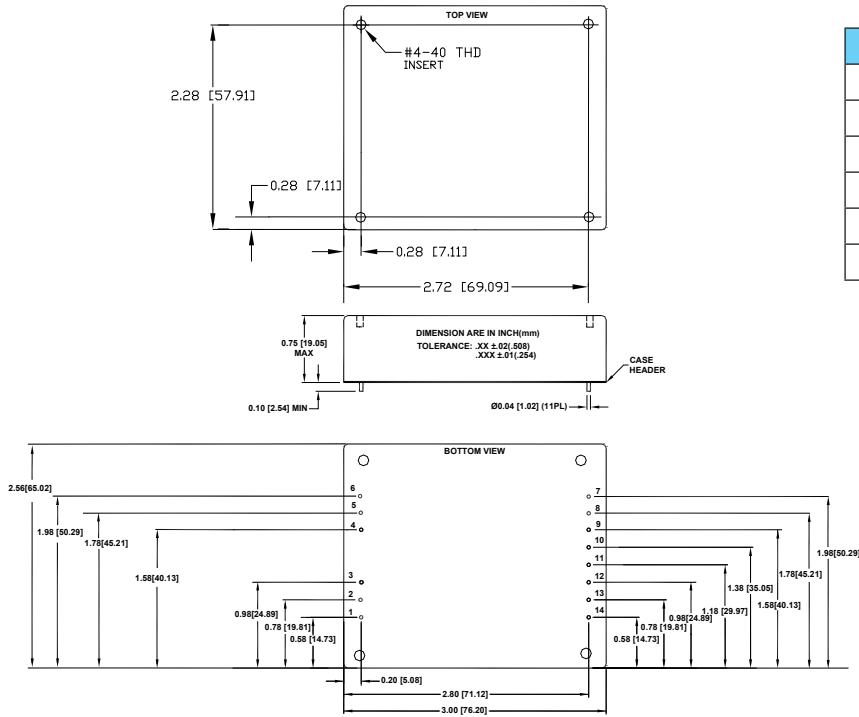

FIGURE 3. Turn on delay and soft start for single AHV50

MECHANICAL SPECIFICATIONS



Pin	Function	Pin	Function
1	ON/OFF	7	+V _{O3}
2	SYNC	8	-V _{O3}
3	+V _{IN}	9	+V _{O2}
4	NO Pin	10	±V _{O2}
5	NO Pin	11	-V _{O2}
6	-V _{IN}	12	+V _{O1}
		13	-V _{O1}
		14	V _O ADJ

MECHANICAL SPECIFICATIONS for HEAT SINK

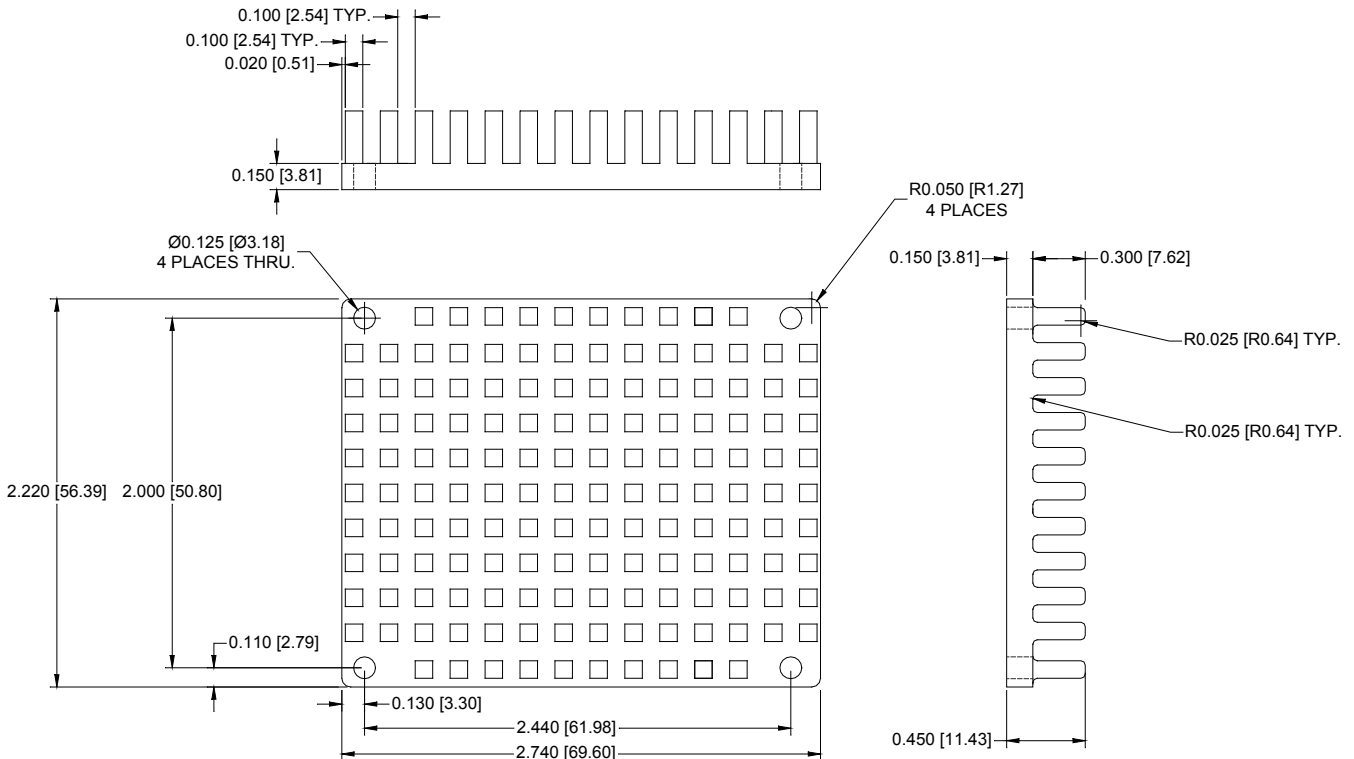

FIGURE 4. Optional Heat Sink for the AHV50 DC-DC Converter

EXTERNAL SYNCHRONIZATION

The converter can be synchronized to an external clock. The external clock MUST have a higher frequency than that of the converter's switching frequency. The amplitude of the external clock pulse must be 3.7 volts or greater and its duration between 15nS to 150nS for sync pulse detection.

The circuit in Figure 5 can be used to produce a 50nS to 150nS pulse from a square wave. The circuit will be turned on by the negative edge of the square wave and will stay on for approximately 50nS (depending on the $R2 \cdot C1$ time constant) (See Figure 6).

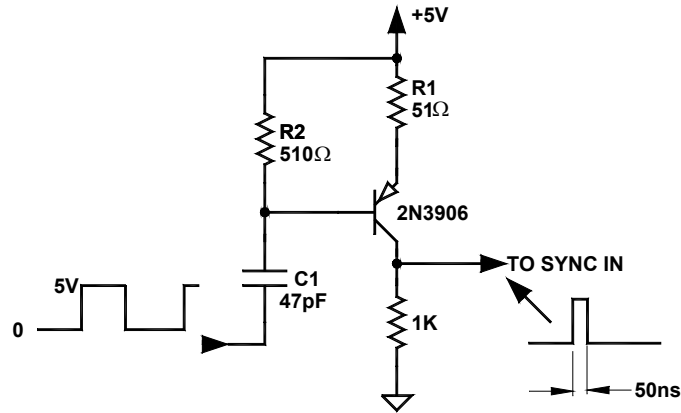

FIGURE 5. 50nS pulse generator from a square wave TTL/5V CMOS clock

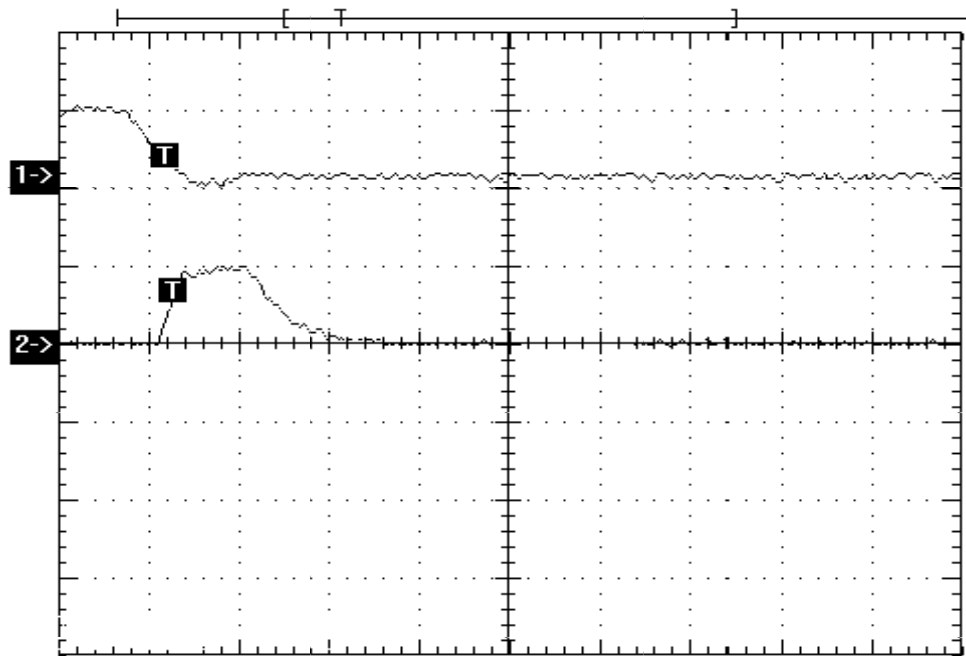
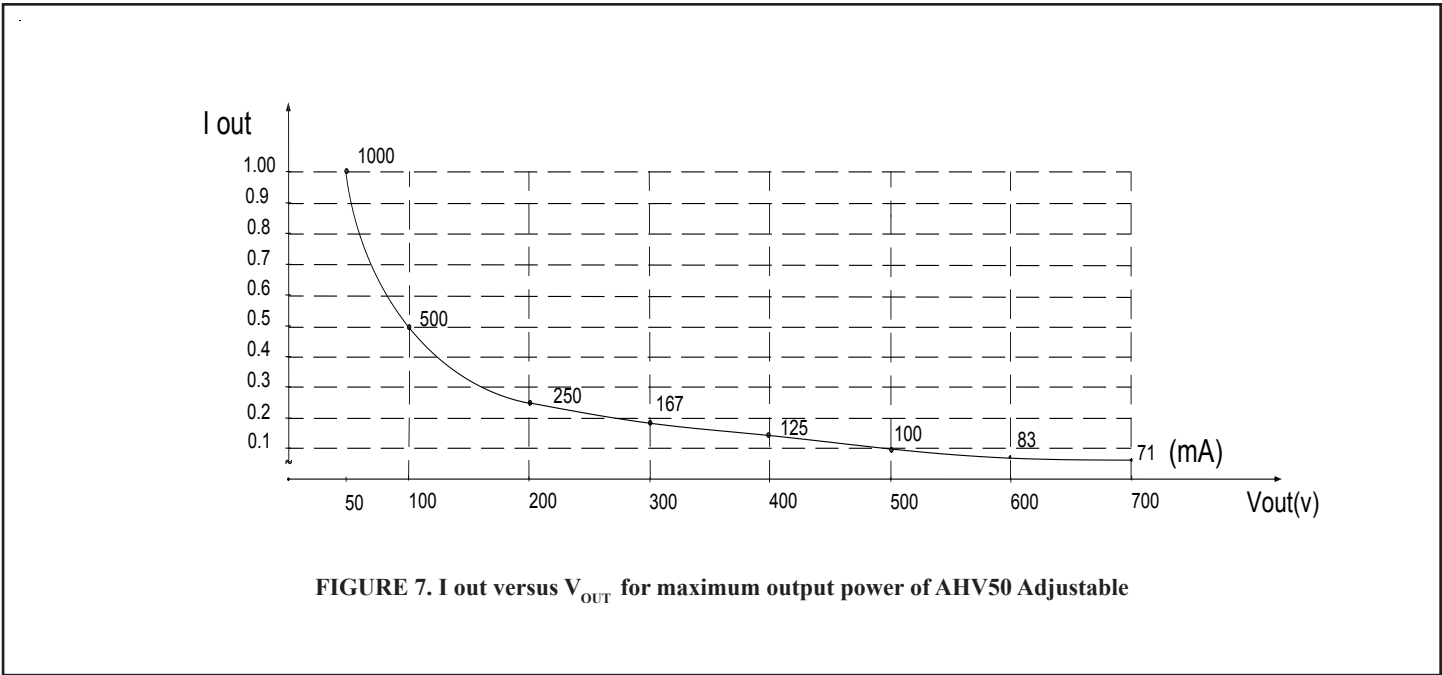
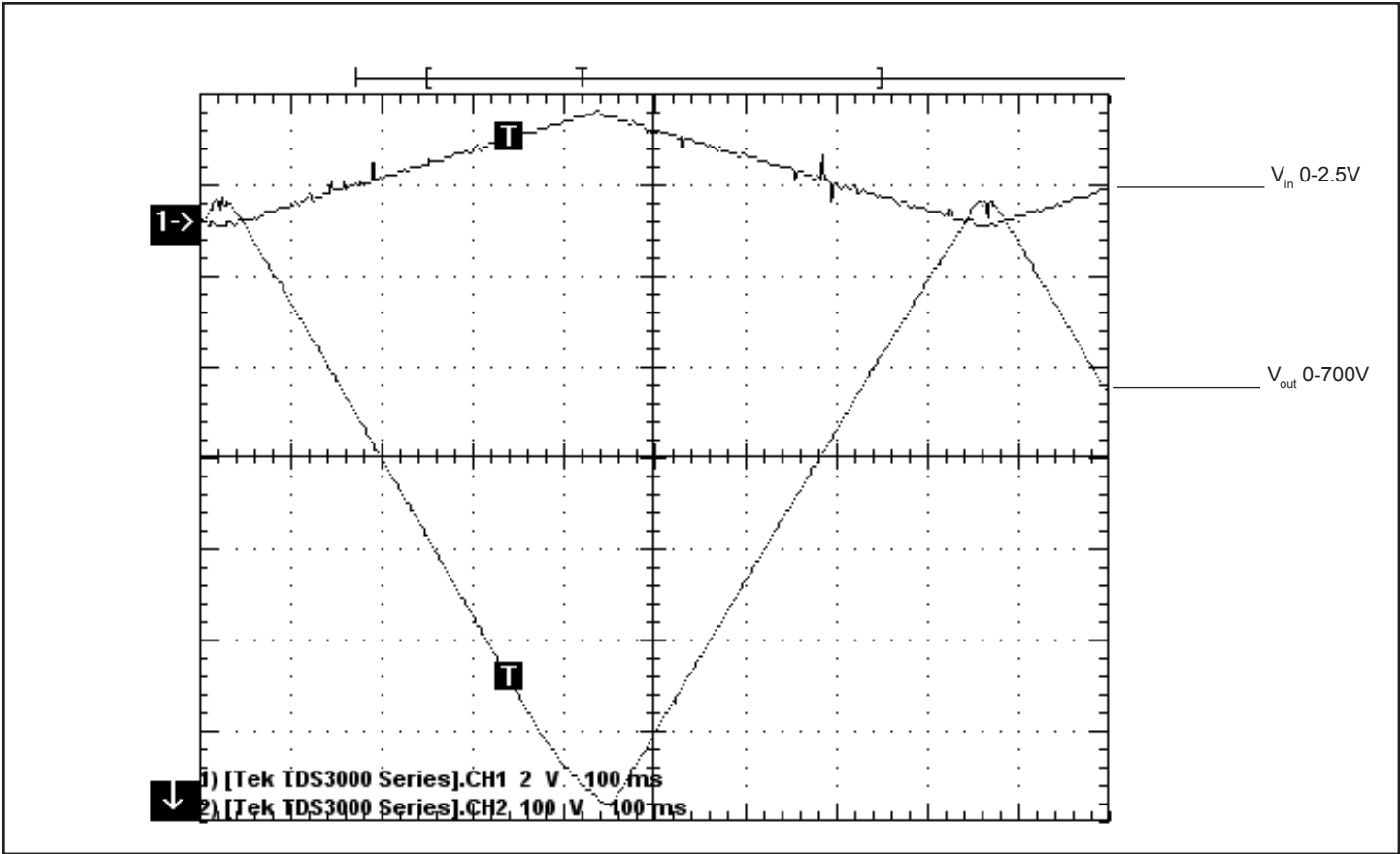

FIGURE 6. Waveforms generated from circuit in Figure 5



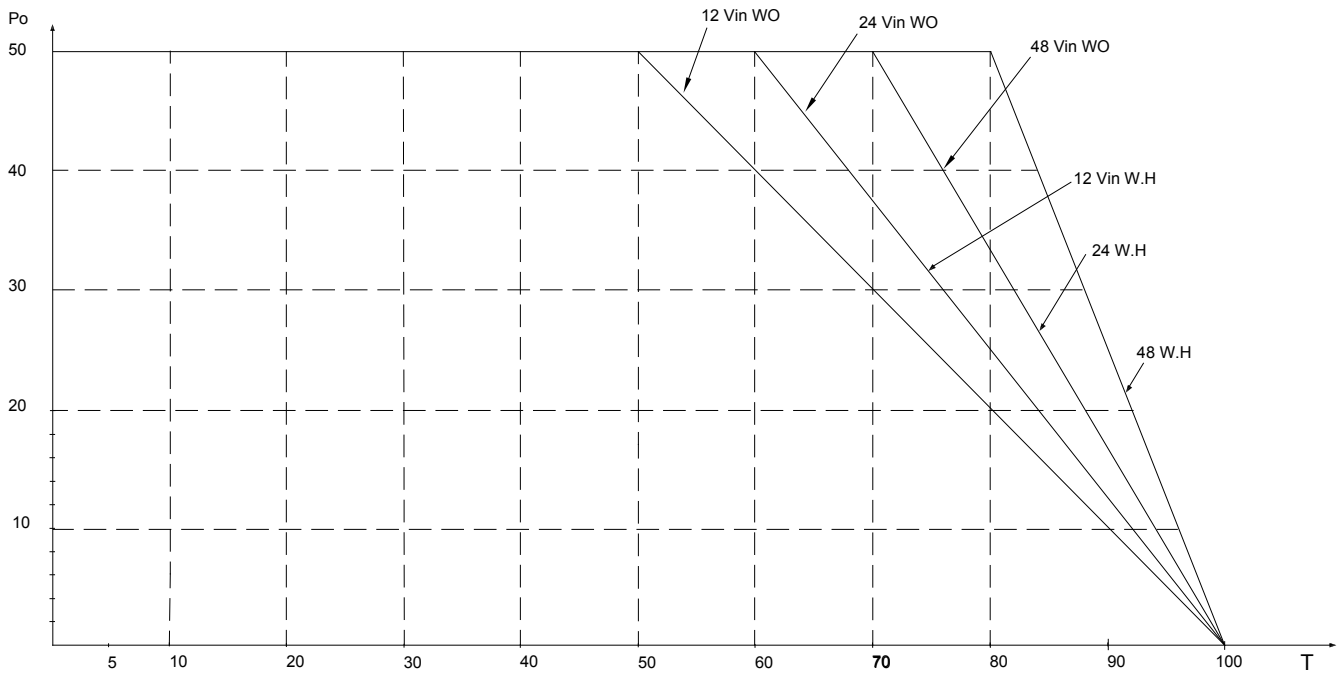

FIGURE 8. Derating Curves of the AHV50 without heatsink. For AHV50 with heatsink add 10°C to the above curves

WO= Without Heatsink W.H= With Heatsink