



AD35

35W HIGH-VOLTAGE ADJUSTABLE DC/DC CONVERTER

0 to 200Vdc Single Output, 0 to ±100Vdc Dual Output

Key Features

- Less than 10mV output noise
- Efficiency up to 88%
- Wide input voltage range (2:1)
- Six-sided shielding
- Soft start
- Single/Dual
- Short circuit and thermal protection
- Adjustable output
- 750µA off state current
- 500mV dropout linear regulators
- Dual output tracking linear regulator



Beta Dyne is protected under various patents, including but not limited to U.S. Patent numbers: 5,777,519; 6,188,276; 6,262,901; 6,452,818; 6,473,3171.

Applications

- High-Resolution Data Converters
- Instrumentation
- Test & Measurement
- Telecom

Functional Description

The AD35 series is a family of 2:1 input voltage range DC/DC converters with a programmable output voltage of 0Vdc to 200Vdc when configured as a single output or 0Vdc to ±100Vdc when configured as a dual output. The converter offers excellent linearity, low noise, and high efficiency by utilizing Beta Dyne's patented technology. The converter can be programmed from a 0–5V source such as a D/A converter or from its own onboard low TC 5V reference. Other standard features include input-to-output isolation, overvoltage protection, dual linear regulators, and thermal protection. The converter comes packaged in a 3.0×2.5×0.5-inch 30-mil copper case that allows for operation without derating or a heatsink up to 71°C. Custom input/output voltage ranges are available upon request.

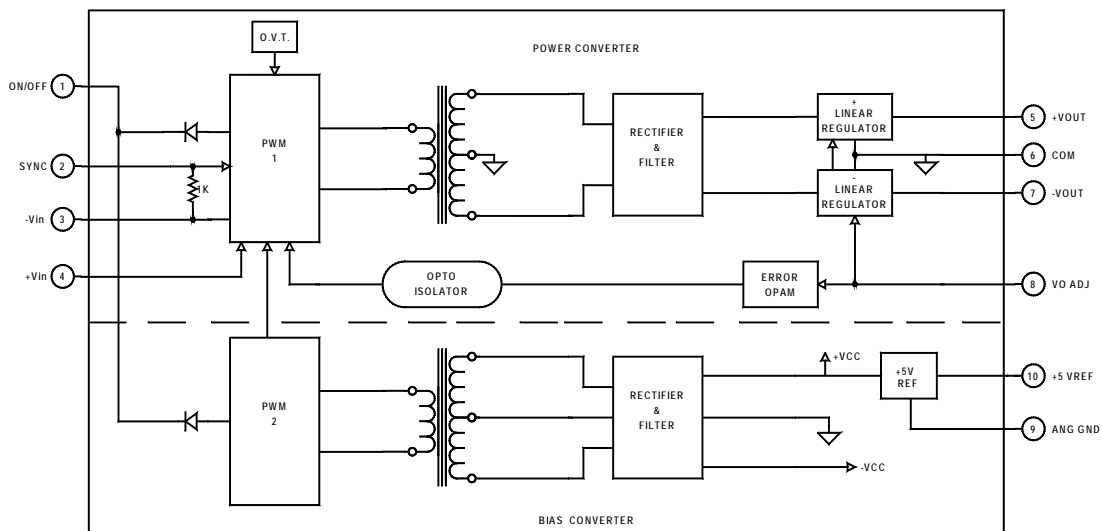

Typical Block Diagram

Unless otherwise specified, all parameters are given under typical +25°C with nominal input voltage and under full output load conditions.

Electrical Specifications

INPUT SPECIFICATIONS

PARAMETER	CONDITION / NOTE	MIN	TYP	MAX	UNIT
Input Voltage Range	See Model Selection Guide				
Startup Voltage for Bias Converter		4.7	5		Vdc
Input Startup Voltage, 12V _{IN}		10.5	11		Vdc
Input Startup Voltage, 24V _{IN}		17	18		Vdc
Input Startup Voltage, 48V _{IN}		35	36		Vdc
Input Startup Voltage, 120V _{IN}		74	75		Vdc
Input Overvoltage Protection, 12V _{IN}		19	20		Vdc
Input Overvoltage Protection, 24V _{IN}		37	38		Vdc
Input Overvoltage Protection, 48V _{IN}		74	76		Vdc
Input Overvoltage Protection, 120V _{IN}		145			Vdc
Input Filter	LC				
Reverse Polarity	Internal parasitic shunt diodes				
Reflected Ripple	I _o = FL, See Model Selection Guide				
No Load Input Current	See Model Selection Guide				
Input Surge Current (20µS Spike)				10	A
Short Circuit Current Limit	See Short Circuit Protection		150		% I _{IN}
Off State Current			750		µA
Remote ON/OFF Control					
Supply ON	Pin 1 Open (Open circuit voltage: 13V max.)				
Supply OFF		-0.6	0	0.8	Vdc
Logic Input Reference	To -V _{IN} for ON/OFF and SYNC				
Logic Compatibility for Reference	TTL Open Collector or CMOS Open Drain				
Sync, High	See External Synchronization, Figures 8 & 9	2		6	Vdc
Sync, Low	See External Synchronization, Figures 8 & 9	0		0.8	Vdc

OUTPUT SPECIFICATIONS

PARAMETER	CONDITION / NOTE	MIN	TYP	MAX	UNIT
Output Voltage	See Model Selection Guide				
Output Voltage Accuracy			±0.5	±1	%
Ripple & Noise			10	20	mV
Output Current	See Model Selection Guide				
Line Regulation, Single and Dual			±0.2	±0.5	%
Load Regulation, Single			±0.2	±0.5	%
Load Regulation, Dual ²	With balanced loads		±0.2	±0.5	%
Temperature Coefficient @ FL			0.02		%/°C
Transient Response Time	50% FL to FL to 50% FL		200	250	µS
Short Circuit Protection	By input current limiting				
Reference (Pin 10)		4.95	5.00	5.05	Vdc
Accuracy			0.5	1	%
Output Current			10	15	mA
Temperature Coefficient			0.003		% of V _{NOMINAL} / °C
V _o ADJ (Pin 8)	Reference to Analog Ground (Pin 9)				
V _o ADJ Input Impedance	10k (Pin 8 to Pin 9)		10		kT

GENERAL SPECIFICATIONS

PARAMETER	CONDITION / NOTE	MIN	TYP	MAX	UNIT
Efficiency	See Model Selection Guide				
Isolation Voltage (1 min.), Input to Output			500		Vdc
Isolation Voltage (1 min.), Output to Output			500		Vdc
Isolation Resistance			10 ⁹		T
Isolation Capacitance			2700		pF
Switching Frequency, Power Stage			330		kHz
Switching Frequency, BIAS Stage			330		kHz
Turn On Delay	See Figure 4		12	20	mS
Soft Start Time	See Figure 4		12	20	mS

ENVIRONMENTAL SPECIFICATIONS

PARAMETER	CONDITION / NOTE	MIN	TYP	MAX	UNIT
Operating Temperature, Industrial (Ambient)*		-40		+71	°C
Operating Temperature, Extended (X)	See Ordering Guide (Please contact factory)	-55		+85	°C
Storage Temperature Range		-55		+125	°C
Thermal Resistance			3.5	4	°C/W _{DISS}
Maximum Operating Case Temperature				105	°C
Thermal Turn Off, Case Temperature		95	100	115	°C
Thermal Hysteresis			20		°C
Derating					
Humidity	Up to 95% non-condensing				
Cooling	Free-air convection				
EMI/RFI	Six-sided continuous shielded metal case				
MTBF	per MIL-HNBK-217F (Ground benign, +25°C)		485,000		hours

* See footnotes 3, 4, 5 and 6

PHYSICAL CHARACTERISTICS

PARAMETER	CONDITION / NOTE	MIN	TYP	MAX	UNIT
Dimensions (L×W×H)	3.00×2.50×0.50 in. (76.20×63.50×12.70mm)				
Weight	5.2 oz. (147g)				
Case Material	Coated metal				
Shielding Connection, 5, 12, 24V _{IN}	-Input (Pin 3)				
Shielding Connection, 48, 120V _{IN}	+Input (Pin 4)				

SEE APPLICATION NOTE DC-021

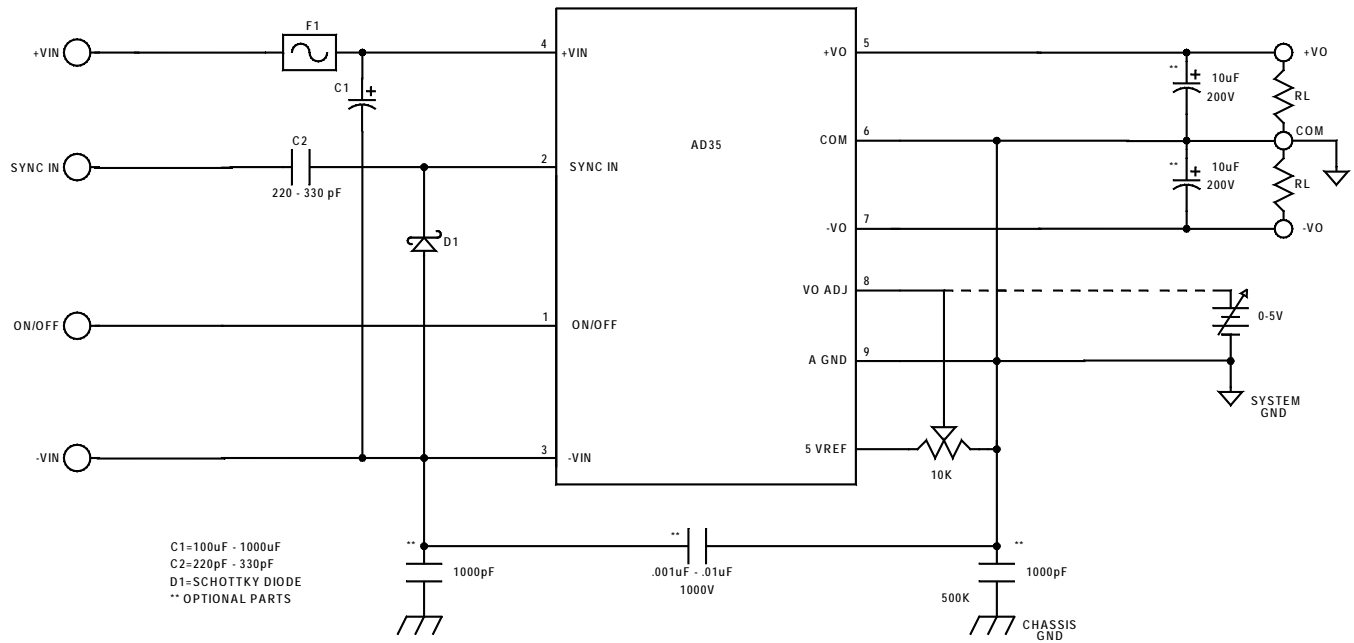
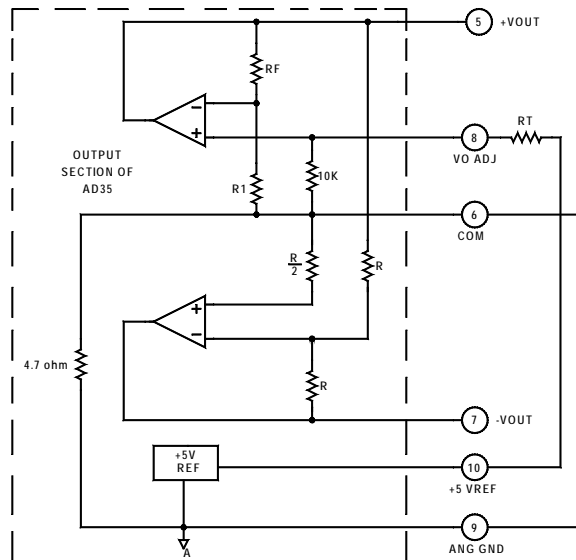

FIGURE 2. Typical connection diagram of AD35 Dual Output (±1Vdc to ±100Vdc)

SEE APPLICATION NOTE DC-021



$$R_F = 20 \cdot R_1$$

$$\sqrt{+V_o} = 21 \cdot V_o \text{ ADJ}$$

$$\sqrt{-V_o} = -\sqrt{+V_o}$$

$$R_T \text{ (in k}\Omega\text{)} = \frac{1050}{V_o} - 10$$

FIGURE 3. Output voltage trim

MECHANICAL SPECIFICATIONS

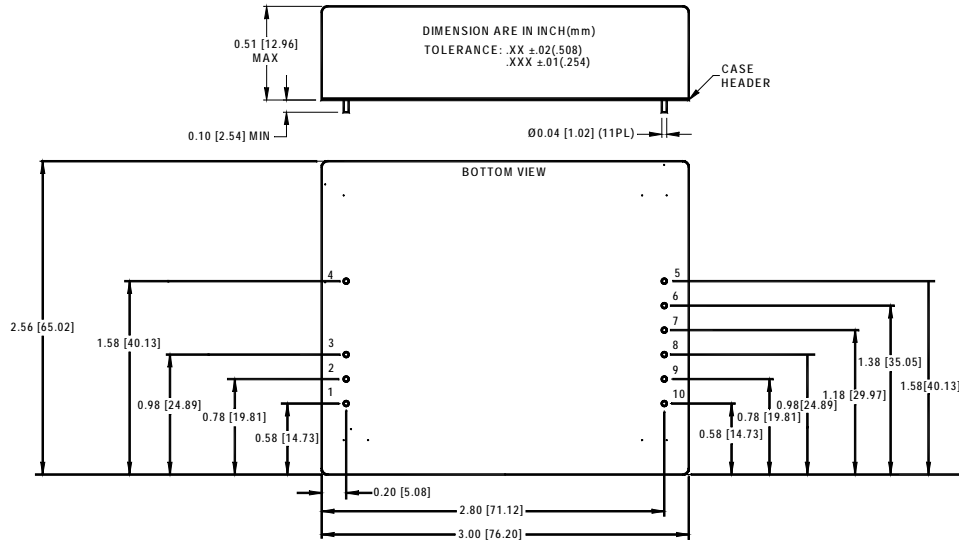

Pin	Function
1	ON/OFF
2	SYNC
3	-V _{IN}
4	+V _{IN}
5	+V _{OUT}
6	COM
7	-V _{OUT}
8	V _O ADJ
9	ANG GND
10	+5 V _{REF}

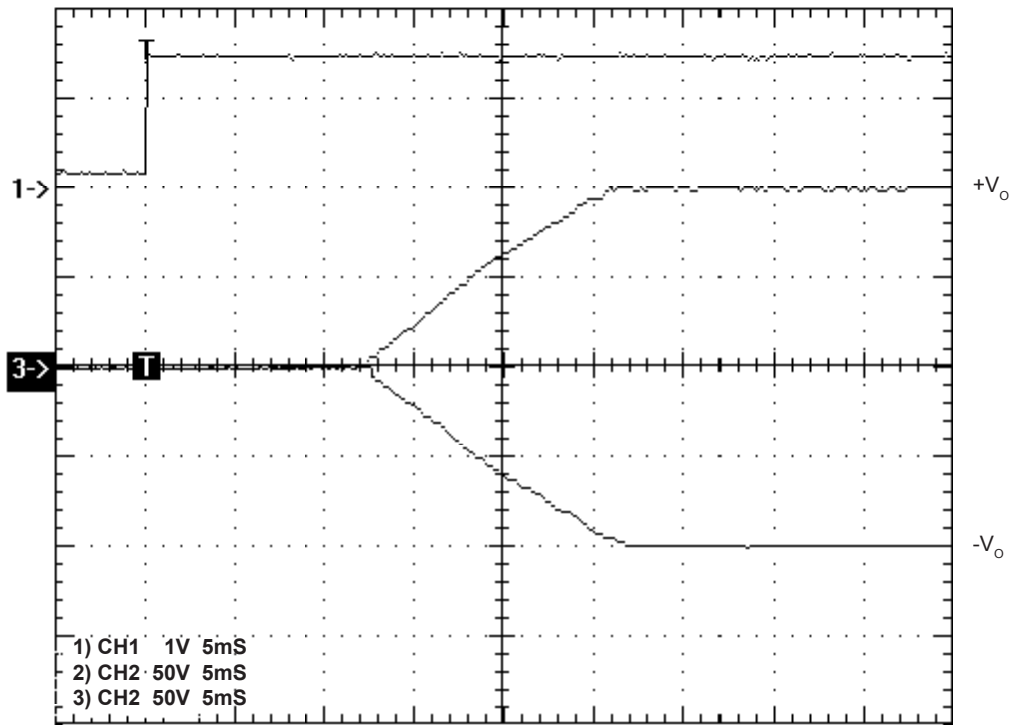

FIGURE 4. Turn on delay and soft start for $\pm V_{OUT}$

NOTE: The soft start time also depends on the external output capacitors.

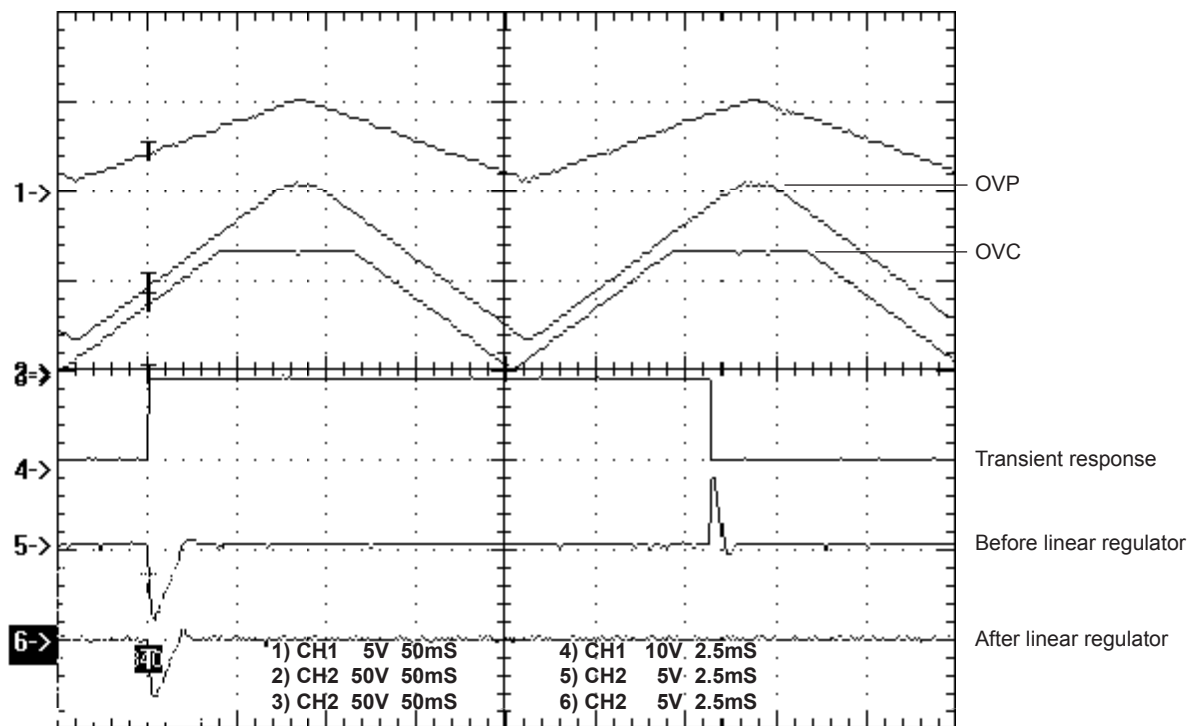

FIGURE 5. Protection features and Transient response

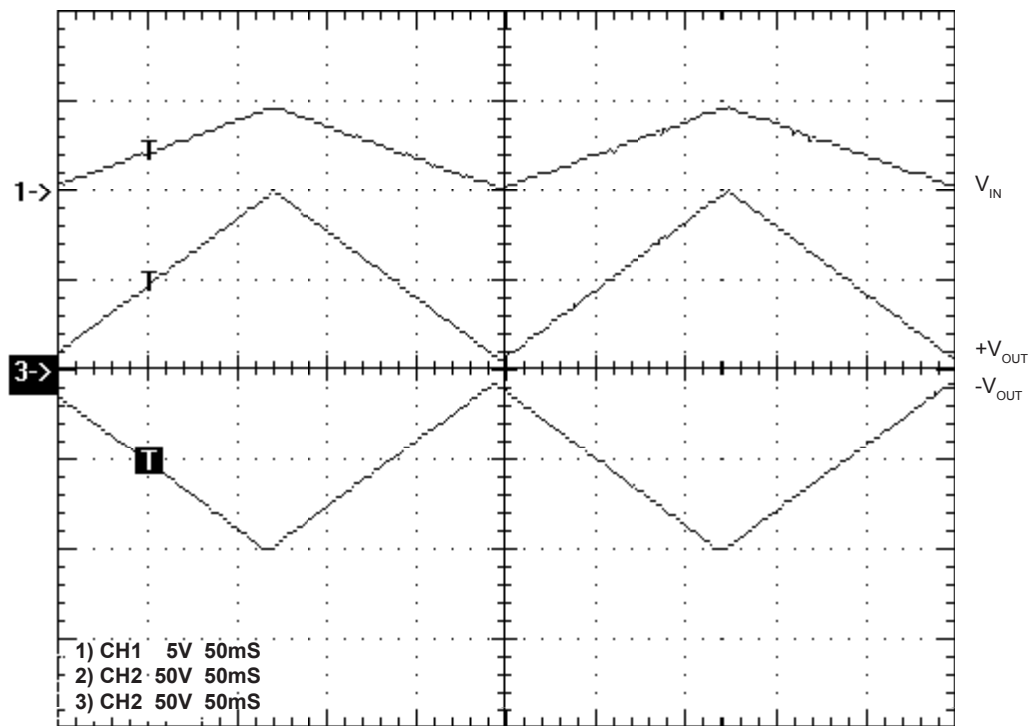

FIGURE 6. V_{IN} vs. $\pm V_{OUT}$

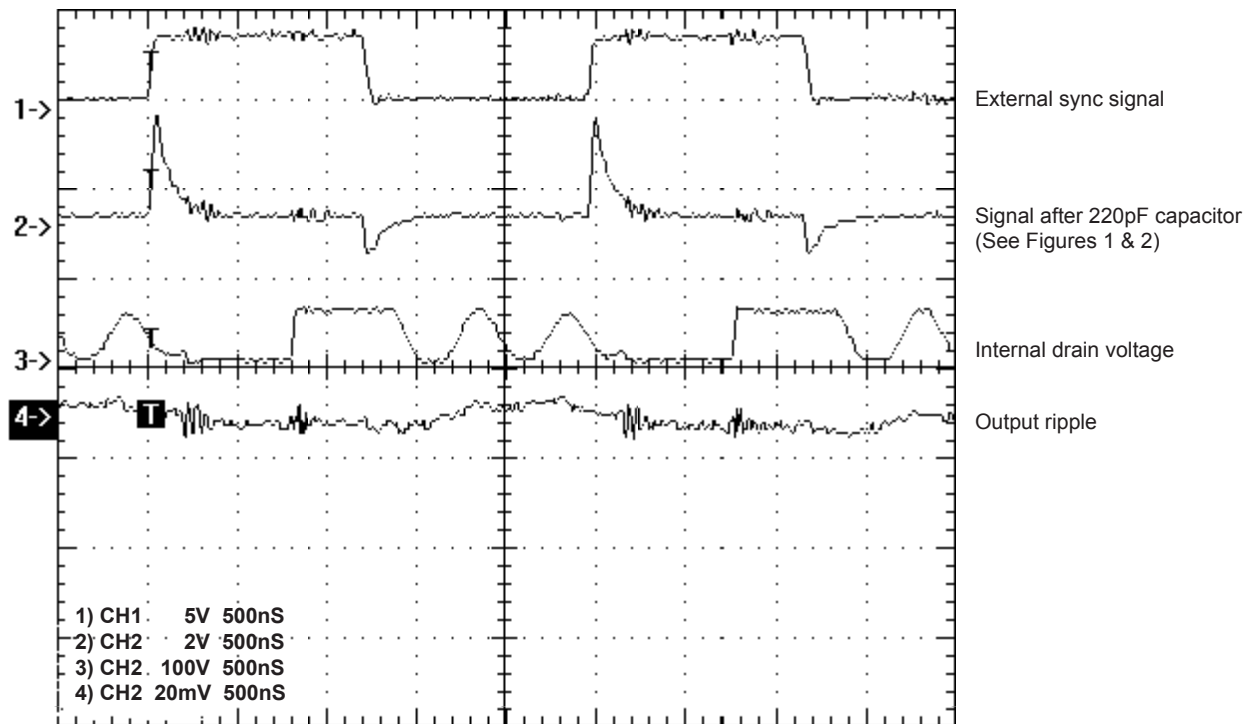

FIGURE 7. External synchronization waveforms obtained using connection diagrams from Figures 1 & 2

SHORT CIRCUIT PROTECTION

The converter has a dual short circuit protection feature. At the input side of the converter, two short circuit current comparators are used to monitor the input current of the converter. They are biased at different voltage levels; the lower threshold (LTH) comparator provides the power limiting function of the converter. Under normal operating conditions, the LTH comparator limits the output power of the converter when the maximum output power is exceeded.

When a hard short is applied across the output of the converter and the input current exceeds the set threshold of the second

comparator, the converter goes into shutdown mode, the overcurrent latch is set and the converter is turned off. The converter will turn on again when its input voltage is recycled (OFF-ON) or if the ON/OFF pin is used to turn the converter on and off. The time required for the ON/OFF pin to be held low is between 100mS and 800mS.

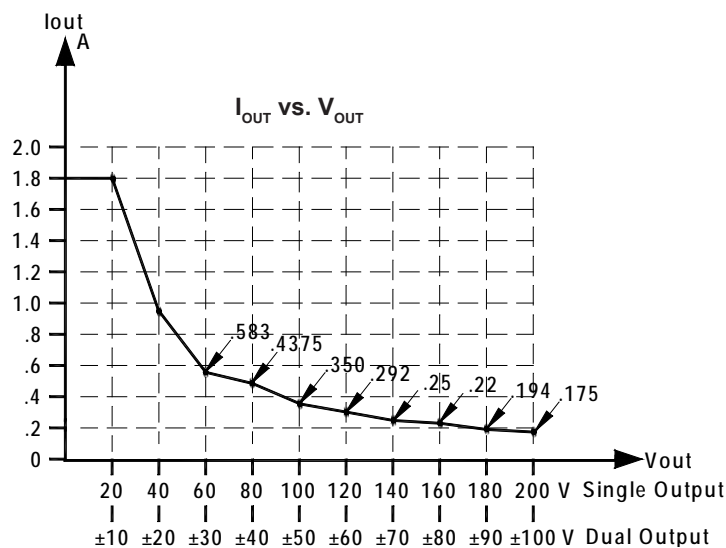

FIGURE 8. Maximum output power graph

EXTERNAL SYNCHRONIZATION

A TTL signal applied at the SYNC pin of the converter will synchronize the switching frequency of the converter to that of the TTL input signal. The external (TTL) frequency must be equal or higher than the converter's frequency. At the positive-going edge of the applied pulse, the internal power-switching transistor turns off and the PWM discharges its timing capacitor. At the negative-going edge, the PWM resumes normal operation. The minimum positive pulse width of the TTL signal must be 300nS minimum and its frequency

between 320kHz and 340kHz. NOTE: Higher frequencies will reduce the efficiency of the converter and wide TTL pulses will force the PWM to follow the external TTL width modulation, which may effect regulation. A high TTL signal at the SYNC pin of the converter will turn the converter off. An internal pull-down resistor will keep this pin low when it is not used. A pulse differentiator (see Figure 10) can be used to shape a square wave sync signal as shown in Figure 9.

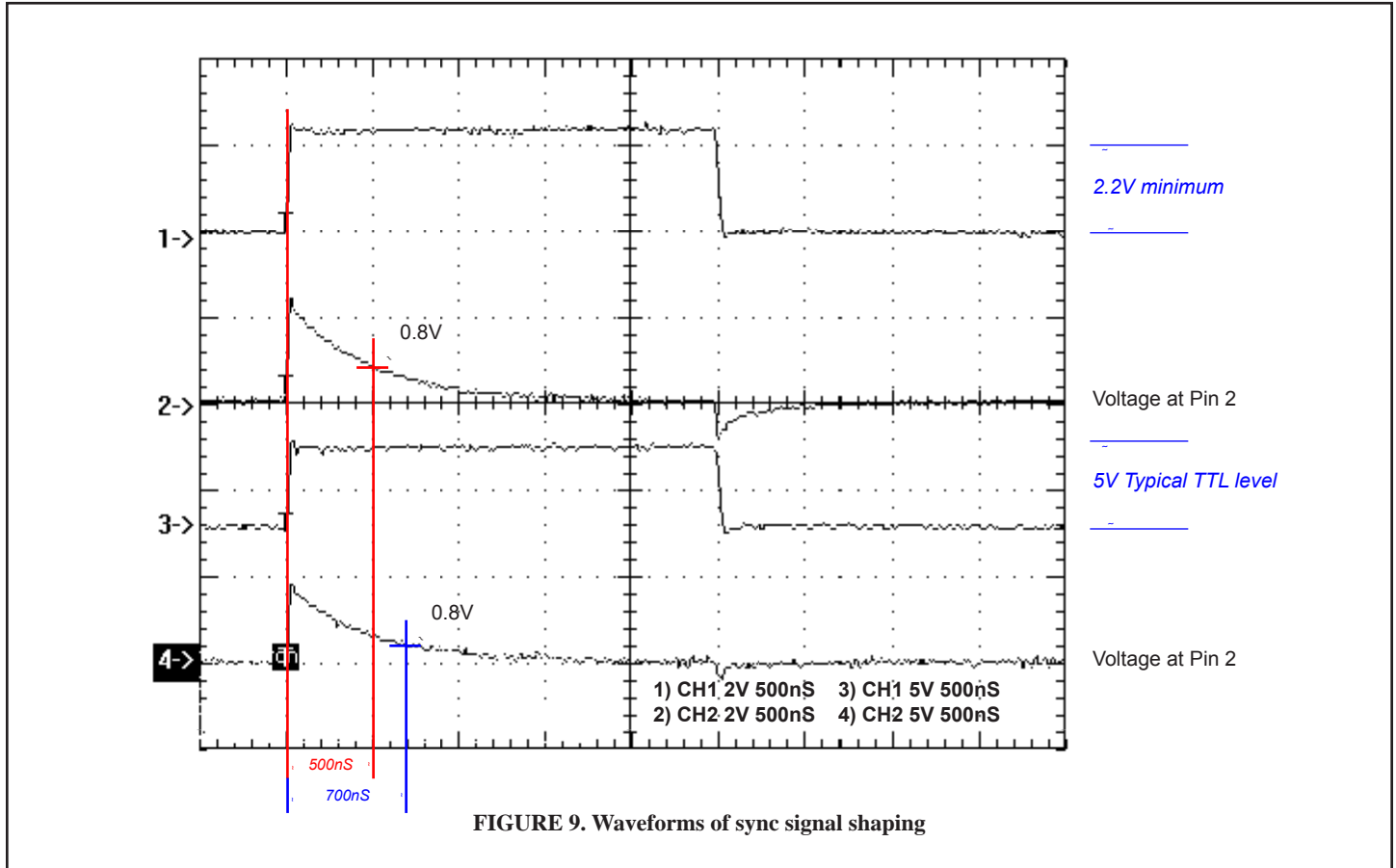

FIGURE 9. Waveforms of sync signal shaping

SYNC SIGNAL SHAPING

As described in External Synchronization, the PWM of the converter requires a TTL signal of 0.8 to 2Vdc minimum amplitude and minimum duration of 300nS. When such a signal is not available (through one shot multivibrator or other pulse-shaping circuits) a C-R differentiator, such as the one in Figure 10, can be used to shape a square wave TTL signal. As is shown by the oscillogram in Figure

9, the positive edge of the sync pulse must be 2V minimum and the decaying exponential must reach the low 0.8Vdc in 300nS minimum from the positive edge. The parallel diode with the resistor is a small signal switching diode or a Schottky signal diode with 0.3 to 0.5V forward drop, it is used to clamp the voltage at pin 2@-0.5Vdc.

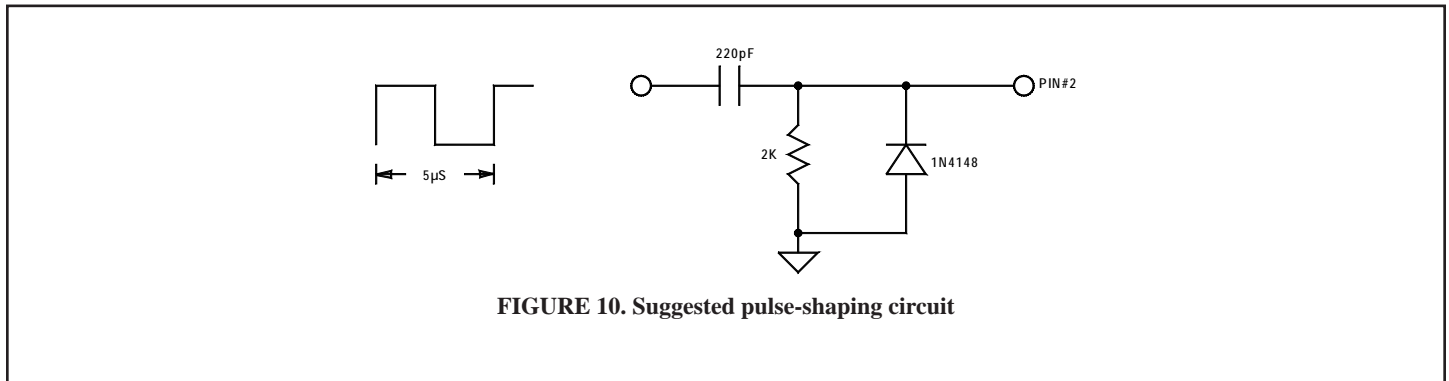

FIGURE 10. Suggested pulse-shaping circuit