



25W DC/DC CONVERTER

Industry's Fastest Settling

DC/DC Converter

US Patent 6,262,901 B1

Key Features

- 25 μ S transient response
- Efficiency up to 86%
- Wide input voltage range (2:1)
- Soft start
- Single/Dual/Triple
- Short circuit protection
- Adjustable output
- 75 μ A off state current
- Synchronization
- Six-sided shielding
- Industry pinout
- Input under & overvoltage protection
- Output overvoltage protection
- Thermal protection

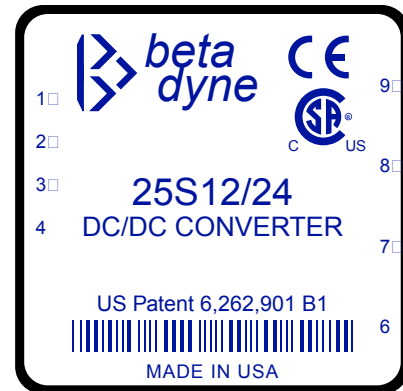

Beta Dyne is protected under various patents, including but not limited to U.S. Patent numbers: 5,777,519; 6,188,276; 6,262,901; 6,452,818; 6,473,3171.

Applications

- Telecom
- Computers
- Instrumentation
- Test & Measurement
- Battery Power Systems

Functional Description

The 25W series is a family of high-performance and high power density, isolated DC/DC converters consisting of single, dual and triple output models. State-of-the-art design and packaging techniques make possible the 20W/in³ power density without sacrificing functionality or performance. The 25 μ S transient response time makes these modules ideal for fast-switching load applications and the 75 μ A off-state current drastically reduces the current drain in battery-operated systems.

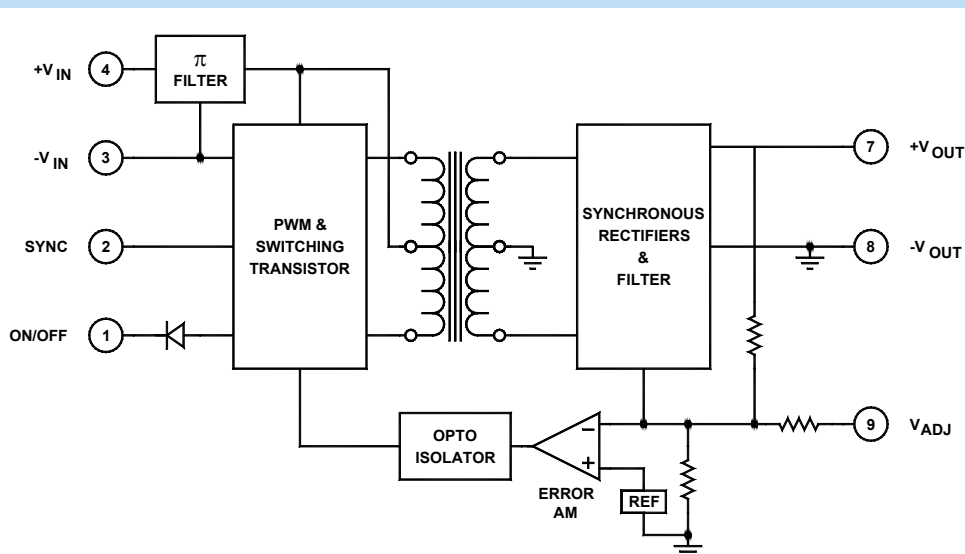

Typical Block Diagram (Single Output)

Electrical Specifications

INPUT SPECIFICATIONS

Unless otherwise specified, all parameters are given under typical +25°C with nominal input voltage and under full output load conditions.

PARAMETER	CONDITION / NOTE	MIN	TYP	MAX	UNIT
Input Voltage Range	See Model Selection Guide				
Input Filter	LC				
Reverse Polarity Input Current Δ	External series-blocking diode			12	A
Input Surge Current (20 μ S Spike)				10	A
Short Circuit Current Limit			150		% I _{IN}
Input Undervoltage / Overvoltage Shutdown, 12V			8 / 20		Vdc
Input Undervoltage / Overvoltage Shutdown, 24V			17 / 38		Vdc
Input Undervoltage / Overvoltage Shutdown, 48V			34 / 75		Vdc
Off State Current			75		μ A
Remote ON/OFF Control					
Supply ON	Open (Open circuit voltage: 12V Max.)				
Supply OFF		0		0.8	Vdc
Logic Input Reference	-Input				
Logic Compatibility	TTL Open Collector or CMOS Open Drain				
Converter Standby Current			32		mA

OUTPUT SPECIFICATIONS

PARAMETER	CONDITION / NOTE	MIN	TYP	MAX	UNIT
Voltage and Current Ratings	See Model Selection Guide				
Output Voltage Accuracy, Single and Dual			± 1		%
Output Voltage Accuracy, Triple (Main)			± 1		%
Output Voltage Accuracy, Triple (Auxiliary)	Fully loaded		3	± 5	%
Output Voltage Adjustment	Single and Dual only		3	± 5	%
Voltage Balance, Dual	Balanced loads		± 1	± 2	%
Voltage Balance, Triple (Auxiliary)	Balanced loads for auxiliary		± 1	± 2	%
Minimum Load		10			% of FL
Ripple & Noise	(See App. Note DC-003)		1	2	%V _{PP} of V _{OUT}
Line Regulation, Single and Dual	Minimum V _{IN} to maximum V _{IN}		± 1	2	%
Line Regulation, Triple (Main)	Minimum V _{IN} to maximum V _{IN}		± 1	2	%
Line Regulation, Triple (Auxiliary)	Minimum V _{IN} to maximum V _{IN}		± 5	5	%
Load Regulation					
Load Regulation, Single	NL to FL		± 1		%
Load Regulation, Dual	Main fully loaded		± 1		%
Load Regulation, Triple (Main)	Main fully loaded		± 1		%
Load Regulation, Triple (Auxiliary)	See Graph		5	6	%
Temperature Coefficient @ FL			0.02		%/°C
Transient Response Time	50% FL to FL to 50% FL		25		μ S
Short Circuit Protection	All outputs, by input current limiting				
Output Short Circuit Duration	Continuous				

GENERAL SPECIFICATIONS

PARAMETER	CONDITION / NOTE	MIN	TYP	MAX	UNIT
Efficiency	See Model Selection Guide				
Isolation Voltage (1 min.)			1500		Vdc
Isolation Resistance			10 ⁹		Ω
Isolation Capacitance			80		pF
Switching Frequency			160		kHz

ENVIRONMENTAL SPECIFICATIONS

PARAMETER	CONDITION / NOTE	MIN	TYP	MAX	UNIT
Operating Temperature, Industrial (Ambient) ¹	See Figure 2	-40		+71	°C
Operating Temperature, Extended	(Please contact factory)				
Storage Temperature Range		-55		+125	°C
Thermal Resistance					°C/W _{DISS}
Maximum Operating Case Temperature				105	°C
Thermal Turn Off, Case Temperature		95	100	115	°C
Thermal Hysteresis		5	10		°C
Derating	See Figure 2				
Humidity	Up to 95% non-condensing				
Cooling	Free-air convection				
EMI/RFI	Six-sided continuous shielded metal case				
MTBF	per MIL-HNBK-217F (Ground benign, +25°C)		718,000		hours

* See footnotes 2, 3, 4 and 5

PHYSICAL CHARACTERISTICS

PARAMETER	CONDITION / NOTE	MIN	TYP	MAX	UNIT
Dimensions (L×W×H)	2.00×2.00×0.395 in. (50.80×50.80×10.03mm)				
Weight	2 oz. (58g)				
Case Material	Coated metal				
Shielding Connection, 12, 24V _{IN}	-Input (Pin 3)				
Shielding Connection, 48, 130V _{IN}	+Input (Pin 4)				

¹ **WARNING** - Usage of input fuse with adequate ratings is essential to avoid possible hazard and damage of the unit. A suppressor diode with adequate ratings is intended to be connected in series to the supply for reverse polarity protection.

² Contact factory for -55° to +85°C operating temperature range.

³ The maximum input current at any given input range measured at minimum input voltage is given as $1.6 \cdot I_{NOMINAL}$. Nominal input current is the typical value measured at the input of the converter under full-load room temperature and nominal input voltage (12, 24 and 48Vin).

⁴ Adequate insulation is to be provided to the converters at the end usage as per applicable requirements.

⁵ Temperature rise on the case of the converters is to be considered during the end usage as per applicable requirements.

EXTERNAL SYNCHRONIZATION

The converter can be synchronized to an external clock by driving the SYNC pin (pin 2) directly or with an open collector-open drain (1 TTL load). The driving signal frequency must be 320kHz ±5% (20% low, 80% high duty cycle). The PWM used in the 25W

series offers bidirectional SYNC ports, which allow multiple unit synchronization by connecting all SYNC pins together. In the absence of an external clock, the faster unit takes control of the SYNC bus and the rest of the units follow.

EXTERNAL TRIMMING OF OUTPUT VOLTAGES

To trim the output voltage DOWN, connect a 5% ¼W resistor between the + (plus) output and trim pins of the converter. To trim the output voltage UP, connect a 5% ¼W resistor between the - (minus) output and trim pin of the converter. For UP/DOWN trimming capability, connect a 10kΩ potentiometer between the + and - pins, with the wiper arm connected to the trim pin. The trim resistors/potentiometer can be connected at the converter output pins or the load. However, if connected at the load, the resistance

of the runs becomes part of the feedback network, improving load regulation. If the load is some distance from the converter, the use of #20 gauge wire is recommended to avoid excessive voltage drop due to the resistance of the circuit paths.

See our application notes:

DC-001: Testing Transient Response in DC/DC Converters

DC-004: Thermal Consideration for DC/DC Converters

ORDERING GUIDE

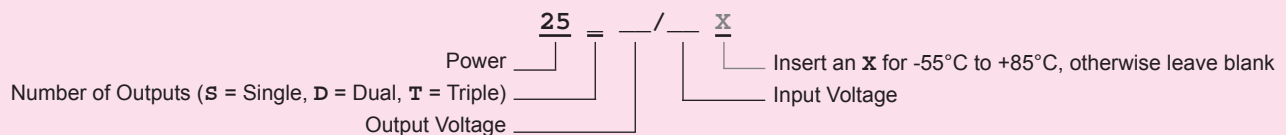

Model Selection Guide

MODEL NUMBER	INPUT				Reflected Ripple (mA _{pp})	OUTPUT		
	Voltage (Vdc)		Current (mA)			Voltage (Vdc)	Current (mA)	Efficiency Full Load (%)
	Nominal	Range	No Load	Full Load				
25S2.5/12	12	9.5–18	30	2030	100	2.5	8000	82
25S3.3/12	12	9.5–18	30	2000	100	3.3	6000	83
25S5/12	12	9.5–18	30	2180	100	5	4400	84
25S12/12	12	9.5–18	30	2000	100	12	1700	85
25S15/12	12	9.5–18	30	1980	100	15	1330	84
25S2.5/24	24	18–36	40	1030	40	2.5	8000	82
25S3.3/24	24	18–36	40	1240	40	3.3	7500	83
25S5/24	24	18–36	40	1210	40	5	5000	86
25S12/24	24	18–36	40	1210	40	12	2080	86
25S15/24	24	18–36	40	1200	40	15	1660	86
25S2.5/48	48	36–72	30	535	40	2.5	8000	78
25S3.3/48	48	36–72	30	620	40	3.3	7500	85
25S5/48	48	36–72	30	620	40	5	5000	84
25S12/48	48	36–72	30	610	40	12	2080	85
25S15/48	48	36–72	30	600	40	15	1660	86
25S5/120	120	75-150	32	154	40	5	3000	81
25D5/12	12	9–18	30	2350	80	+5/-5	±2200	78
25D12/12	12	9–18	30	2260	80	+12/-12	±910	81
25D15/12	12	9–18	30	2250	80	+15/-15	±730	81
25D5/24	24	18–36	40	1270	40	+5/-5	±2500	82
25D12/24	24	18–36	40	1220	40	+12/-12	±1040	85
25D15/24	24	18–36	40	1210	40	+15/-15	±830	86
25D5/48	48	36–72	30	630	40	+5/-5	±2500	83
25D12/48	48	36–72	30	620	40	+12/-12	±1040	84
25D15/48	48	36–72	30	610	40	+15/-15	±830	85
25T3.3-5/12	12	9–18	40	2410	120	3.3/±5	3500/±1000	75
25T3.3-12/12	12	9–18	40	2600	120	3.3/±12	3500/±500	75
25T3.3-15/12	12	9–18	40	2610	120	3.3/±15	3500/±410	76
25T5-12/12	12	9–18	40	2680	120	5/±12	2500/±500	76
25T5-15/12	12	9–18	40	2700	120	5/±15	2000/±333	77
25T3.3-5/24	24	18–36	35	1320	50	3.3/±5	3500/±1200	74
25T3.3-12/24	24	18–36	40	1320	50	3.3/±12	3500/±500	74
25T3.3-15/24	24	18–36	45	1320	50	3.3/±15	3500/±410	75
25T5-12/24	24	18–36	45	1250	50	5/±12	2500/±500	82
25T5-15/24	24	18–36	45	1260	50	5/±15	2500/±410	82
25T3.3-5/48	48	36–72	40	680	40	3.3/±5	4000/±1200	77
25T3.3-12/48	48	36–72	40	640	40	3.3/±12	4000/±500	80
25T3.3-15/48	48	36–72	40	650	40	3.3/±15	4000/±410	82
25T5-12/48	48	36–72	40	620	40	5/±12	2500/±500	82
25T5-15/48	48	36–72	40	620	40	5/±15	2500/±410	83

Contact factory for custom input and output voltage combinations

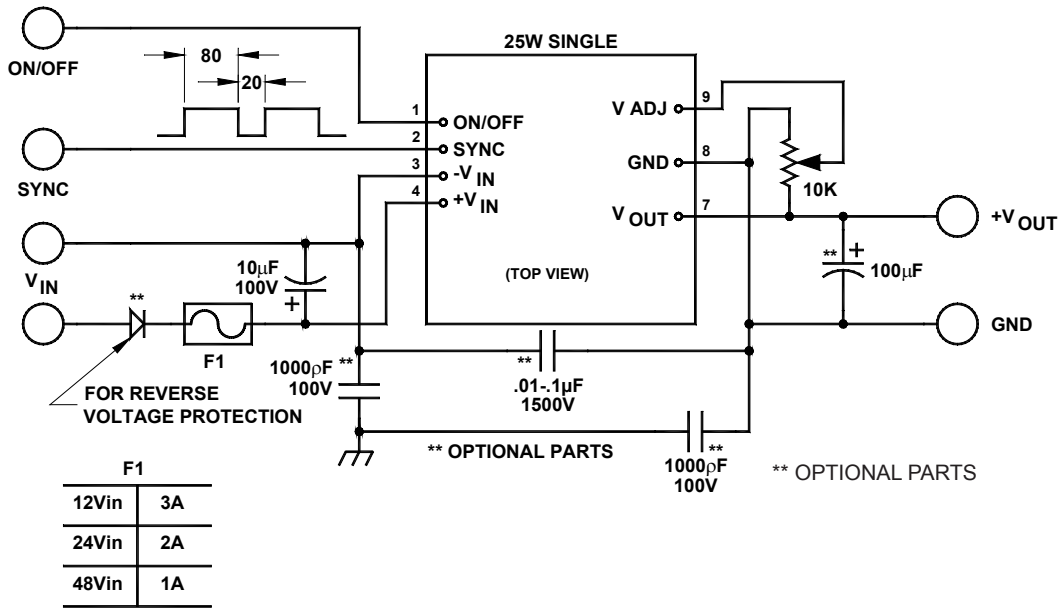

FIGURE 1. Typical connection diagram of 25W Single DC/DC Converter

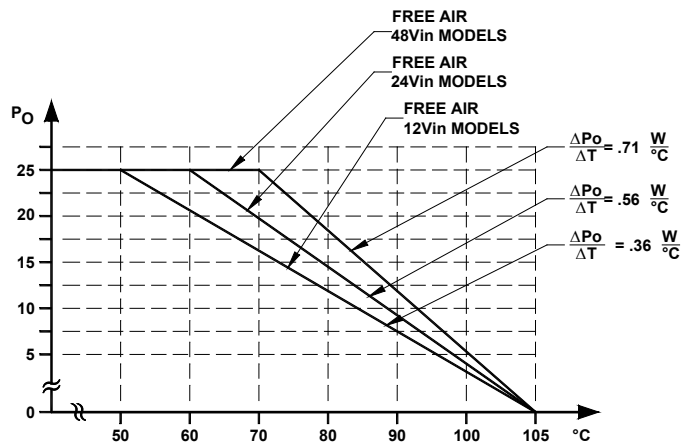
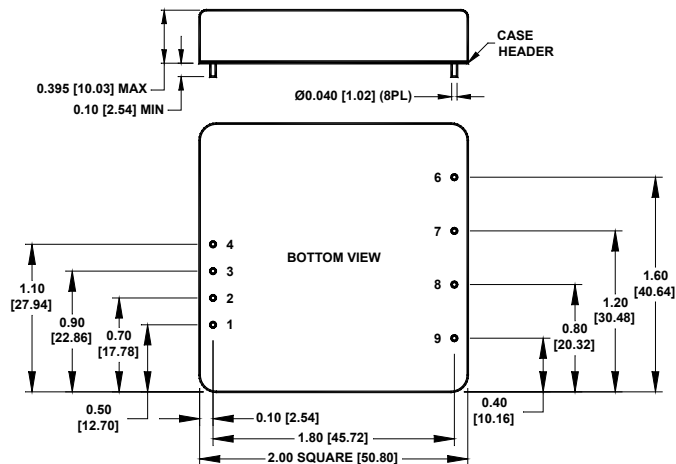

FIGURE 2. Typical derating curves of 25W series

MECHANICAL SPECIFICATIONS

in inches [mm]



Pin	Function		
	SINGLE	DUAL	TRIPLE
1	ON/OFF	ON/OFF	ON/OFF
2	SYNC	SYNC	SYNC
3	-V _{IN}	-V _{IN}	-V _{IN}
4	+V _{IN}	+V _{IN}	+V _{IN}
5	No Pin	No Pin	No Pin
6	No Pin	+V _{OUT}	+V _{AUX}
7	+V _{OUT}	GND	+V _{OUT}
8	-V _{OUT}	-V _{OUT}	GND
9	V _{OUT} ADJ	V _{OUT} ADJ	-V _{AUX}